

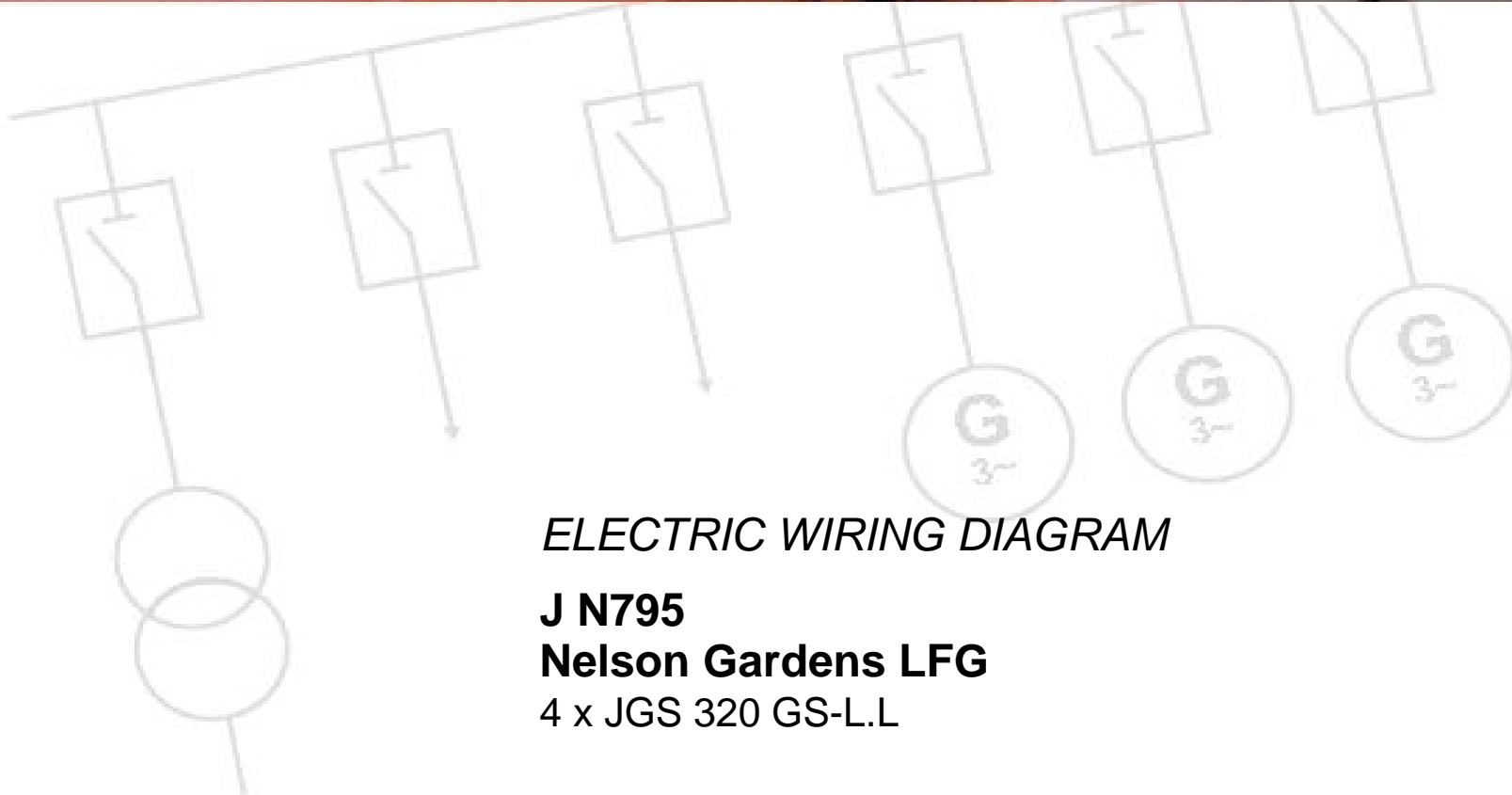

GE Jenbacher



ELECTRIC WIRING DIAGRAM

J N795

Nelson Gardens LFG

4 x JGS 320 GS-L.L



GE Jenbacher

Wiring diagram

This drawing is confidential and proprietary to the General Electric Company. It may not be used in any form, or reproduced in any manner, without the express written permission of the General Electric Company. Copyright, General Electric Company, 2011

The wiring diagram includes : 194 Sheets

Nelson Gardens LFG

4 x JGS 320 GS-L.L



J N795

a			Date	18.01.06	4 x JGS 320 GS-L.L		Jenbacher gas engines	Cover sheet Electric wiring diagram	SD-Nr. Project	8662
			Desig.	Senfter M.	Nelson Gardens LFG				Suffix	J xxxx
			Print	24.04.12					Wiring diagram	J N795 + U / 1
Modific.	Date	Name	Check	Pieschnik A.	DIR: J:\EPLAN4\PROJ\ANLAGEN\XXXX\N7XX\JN795.P	KW 05 - 2011	EPLAN 5			

Over view

Parameters for the operation
of GE Jenbacher Engines
acc. TI.Nr.: 1100-0110

Modifications of Design
reserved.

All Cables between the
Switchboards and the Engine
have to be in flexible mode.

Protection against electric shocks hazard
earthing, equipotential bonding, has to be
provided by the Customer at installation
according to local Standards !
At staes of delivery the engine
is prepared for the protection by
automatic disconnection of supply
in TN-Systems according to
HD 60364-4-41 / IEC 60364-4-41.

 The Numbers in the circles are in
Relation with the Numbers in the
Interface-List J N795

This Wiring Diagram is designed with
a CAE-System.
Modifications will be occupied by
GE Jenbacher

		Date	18.01.06	4 x JGS 320 GS-L.L	 Jenbacher gas engines	Over view	SD-Nr. Project	8662
		Desig.	Senfter M.	Nelson Gardens LFG			Suffix	J xxxx
		Print	24.04.12				Wiring diagram	J N795 + U / 3
Modific.	Date	Name	Check	Pieschnik R.	DIR: J:\EPLAN4\P\ANL\BEN\WXXX\N7XX\JN795.P	KW 05 - 2011	EPLAN 5	

Diagram index

Page	Denomination	Modifications	Page	Denomination	Modifications
+U/1	Cover sheet Electric wiring diagram	a	+U/16	MODBUS-RTU	
+U/2	Electric wiring diagram Version	a	+U/17	Over view Software	
+U/3	Over view		+U/18	Legend of Symbols	
+U/4	Diagram index		+U/19	Legend of Symbols	
+U/5	E-Diagram		+U/20	Requirements for Cablings NEC	
+U/6	Over view groups		+U/21	Cable with DIANE	
+U/7	Over view groups		+U/22	Over view cables	
+U/8	Protection: Generator		+U/23	Kabelübersicht	
+U/9	Grid Import/Export Controller		+U/24	Kabelübersicht	
+U/10	Gangway		+U/25	Kabelübersicht	
+U/11	Over view Panels		+U/26	Kabelübersicht	
+U/12	Electrical connections		+U/27	Kabelübersicht	
+U/13	Potential equalization				
+U/14	Bus diagram				
+U/15	Bus diagram				

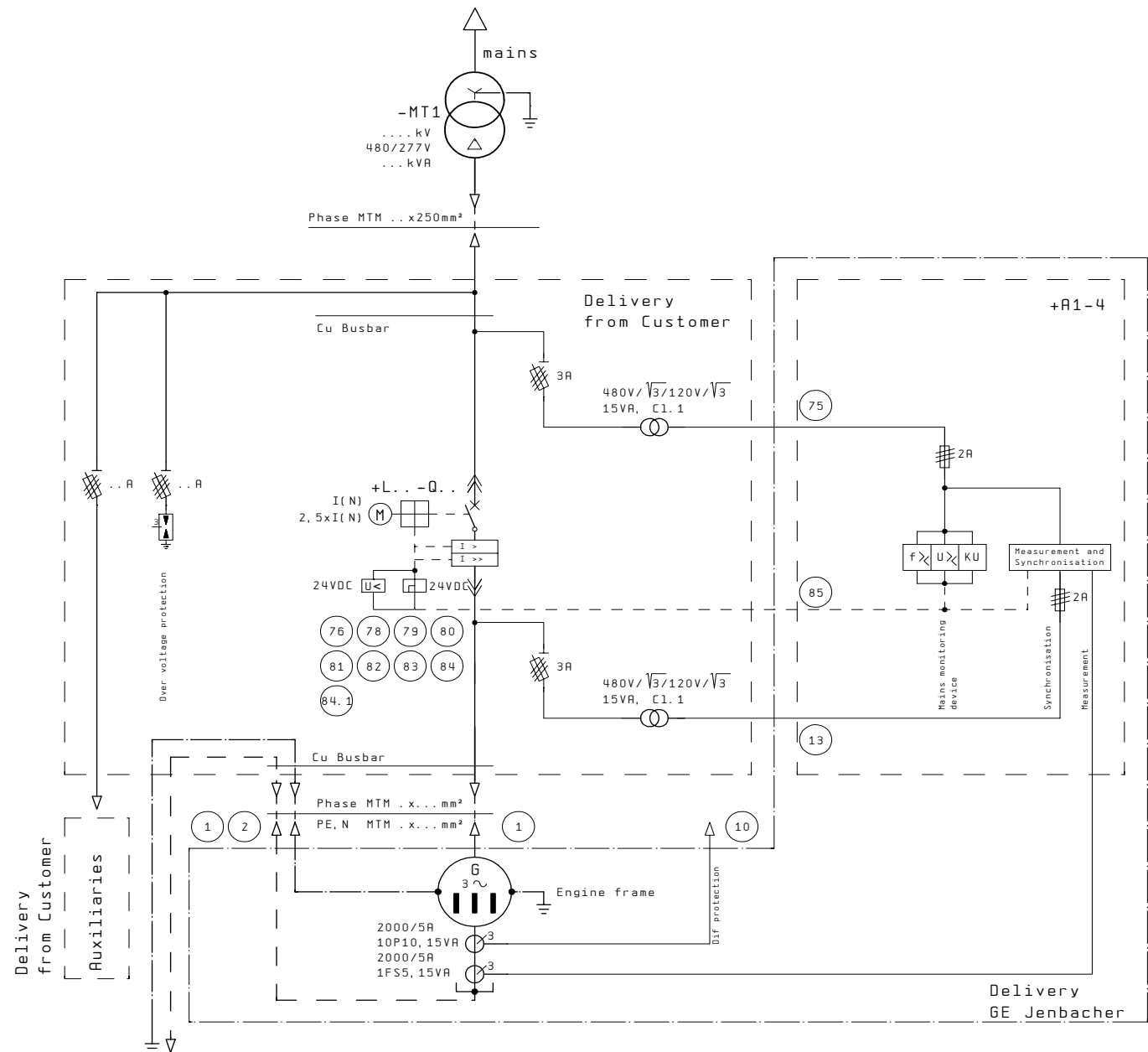

f>: 61,5 Hz
 f<: 59 Hz
 U<: 90 % UN
 U>: 110 % UN
 KU: 8 Grad

Indicators

A	A	A	Ve
V	Hz	cos φ	
kW	kVA	kVar	
kWh	kvarh		

Generator 1-4
 480/277V ±5% 60Hz
 1311kVA 1577A cosφ=0,8
 1059kW 1274A cosφ=1

Over view groups

- +U Over view
- +B Part reference list

- +G1 Generator 1
- +M1 Module interface cubicle 1
- +A1 Module control panel 1
- +DF1 HERMES

- +G2 Generator 2
- +M2 Module interface cubicle 2
- +A2 Module control panel 2

Location

- +E1 Gas engine 1
- +P1 Periphery 1

- +E2 Gas engine 2
- +P2 Periphery 2

		Date	18.01.06	4 x JGS 320 GS-L.L	 Jenbacher gas engines	Over view groups	SD-Nr. Project	8662
		Desig.	Senfter M.	Nelson Gardens LFG		Suffix	J xxxx	
		Print	24.04.12			Wiring diagram	J N795 + U / 6	
Modific.	Date	Name	Check	Pieschnik R.	DIR: J:\EPLAN4\VP\ANL\GEN\WXXX\N7XX\JN795.P	KW 40 - 2011	EPLAN 5	

Over view groups

+G3 Generator 3
 +M3 Module interface cubicle 3
 +A3 Module control panel 3

+G4 Generator 4
 +M4 Module interface cubicle 4
 +A4 Module control panel 4

Location

+E3 Gas engine 3
 +P3 Periphery 3

+E4 Gas engine 4
 +P4 Periphery 4

		Date	18.01.06	4 x JGS 320 GS-L.L	 Jenbacher gas engines	Over view groups	SD-Nr. Project	8662
		Desig.	Senfter M.	Nelson Gardens LFG			Suffix	J xxxx
		Print	24.04.12				Wiring diagram	J N795 + U / 7
Modific.	Date	Name	Check	Pieschnik R.	DIR: J:\EPLAN4\VP\ANLRGEN\XXXX\N7XX\JN795.P	KW 40 - 2011	EPLAN 5	

Protection: Generator

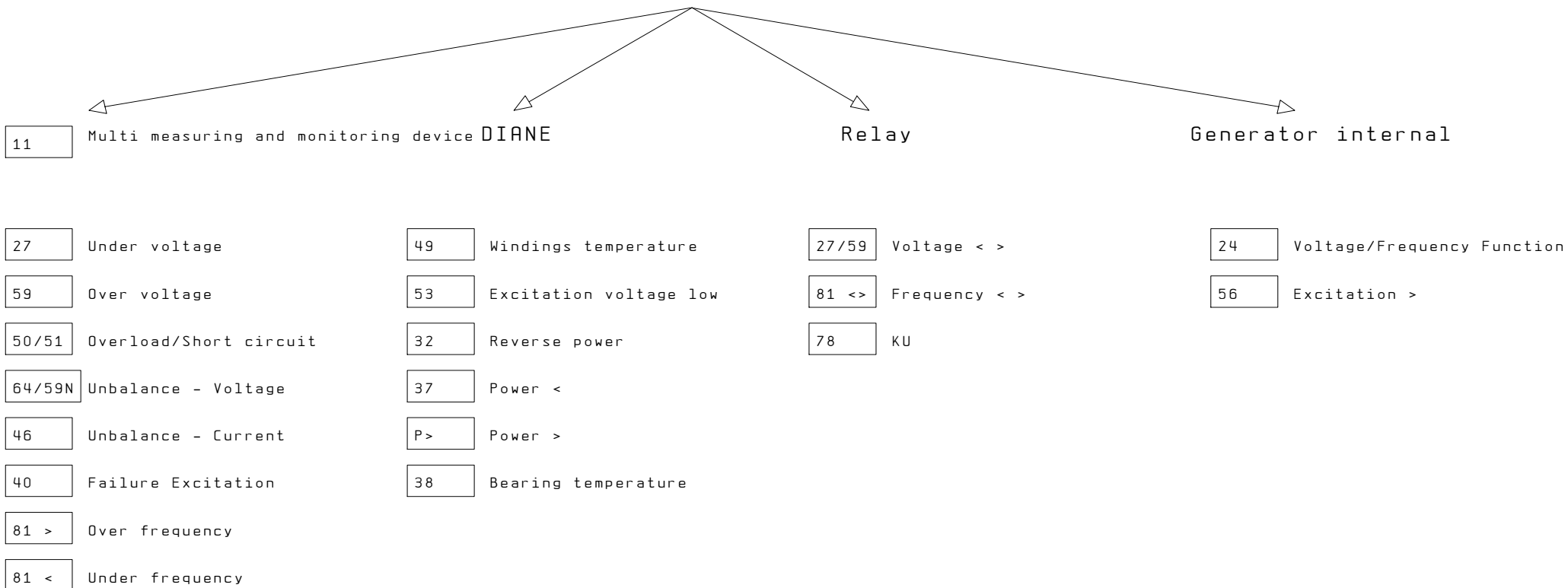

CUSTOMER ↔ GE Jenbacher

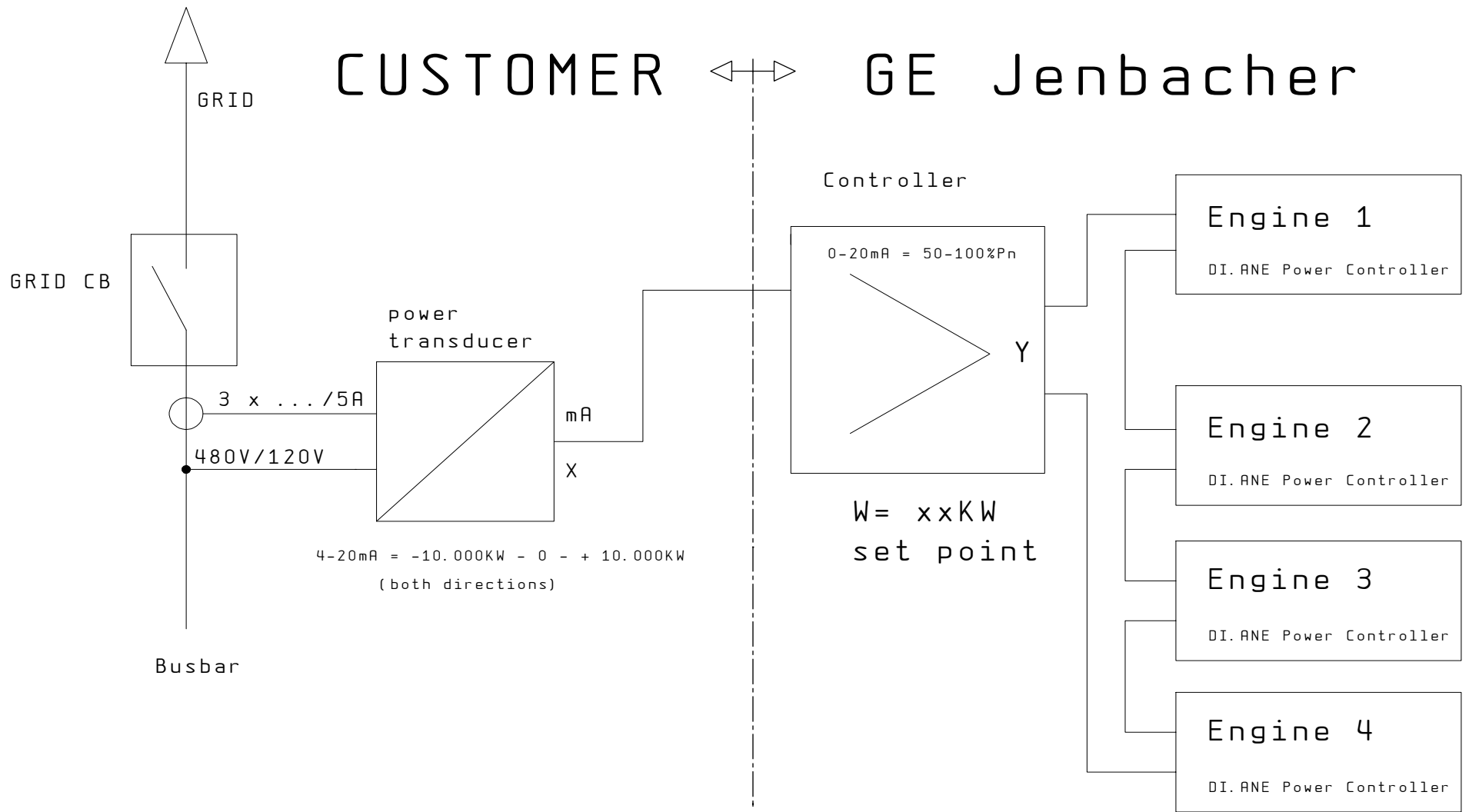

		Date	18.01.06	4 x JGS 320 GS-L.L	 Jenbacher gas engines	Grid Import/Export Controller	SD-Nr. Project	8662
		Desig.	Senfter M.	Nelson Gardens LFG			Suffix	J xxxx
		Print	24.04.12				Wiring diagram	J N795 + U / 9
Modific.	Date	Name	Check	Pieschnik A.	DIR: J:\EPLAN4\VP\ANL\BEN\WXXX\N7XX\JN795.P	KW 40 - 2011	EPLAN 5	

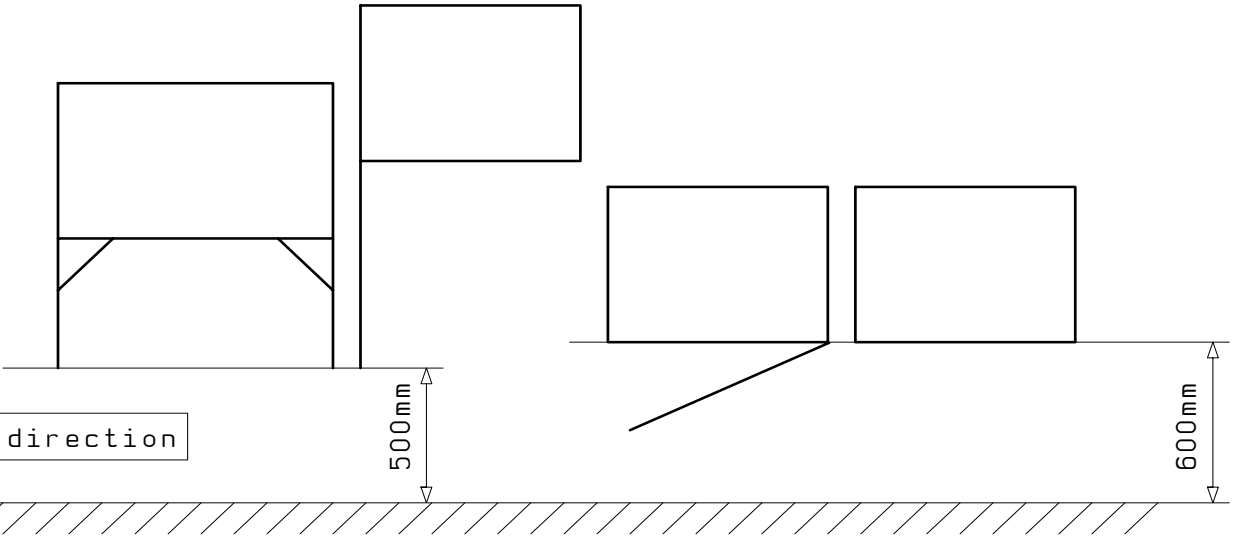
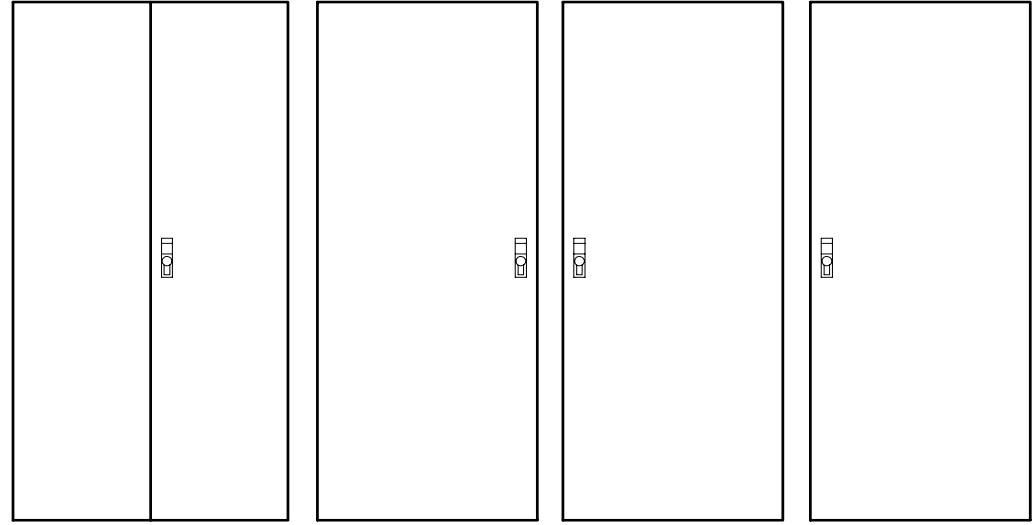

← Evacuation route direction

according : IEC 60364-7-729

		Date	18.01.06	4 x JGS 320 GS-L.L	 Jenbacher gas engines	Gangway	SD-Nr.	8662
		Desig.	Senfter M.	Nelson Gardens LFG			Suffix	J xxxx
		Print	24.04.12				Wiring diagram	J N795 + U / 10
Modific.	Date	Name	Check	Pieschnik R.	DIR: J:\EPLAN4\VP\ANL\GEN\WXXX\N7XX\JN795.P	KW 05 - 2011	EPLAN 5	

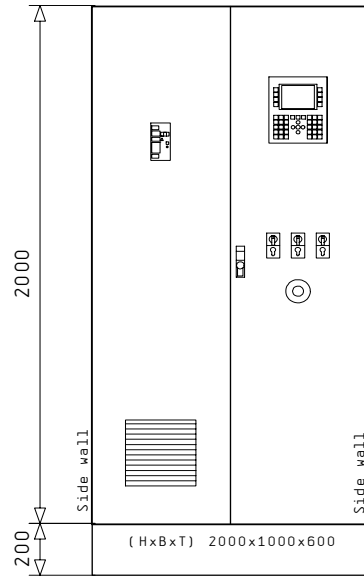
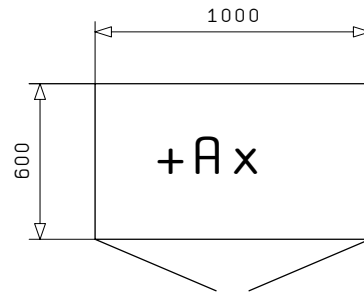

		Date	18.01.06	4 x JGS 320 GS-L.L	 Jenbacher gas engines	Over view Panels	SD-Nr.	8662	/	11
		Desig.	Senfter M.	Nelson Gardens LFG			Suffix	J xxxx		
		Print	24.04.12				Wiring diagram	J N795 + U		
Modific.	Date	Name	Check	Pieschnik A.	DIR: J:\EPLAN4\P\ANL\GEN\WXXX\N7XX\JN795.P	KW 05 - 2011	EPLAN 5			

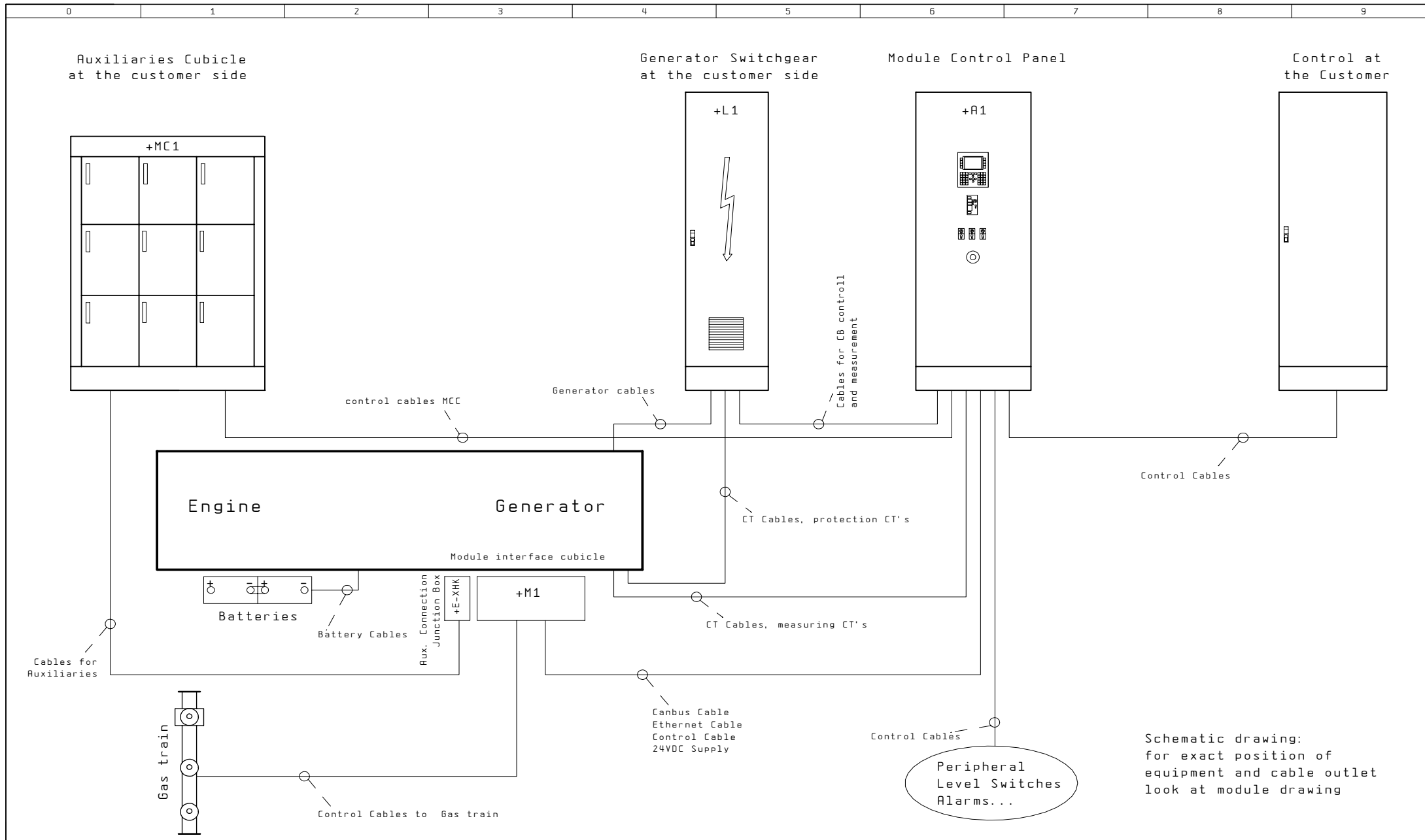

11

13

		Date	18.01.06	4 x JGS 320 GS-L.L	 Jenbacher gas engines	Electrical connections	SD-Nr. Project	8662
		Desig.	Senfter M.	Nelson Gardens LFG		Suffix	J K620	
		Print	24.04.12			Wiring diagram	J N795 + U / 12	
Modific.	Date	Name	Check	Pieschnik A.	DIR: J:\EPLAN4\PLANLGEN\WXXX\N7XX\JN795.P	EPLAN 5		

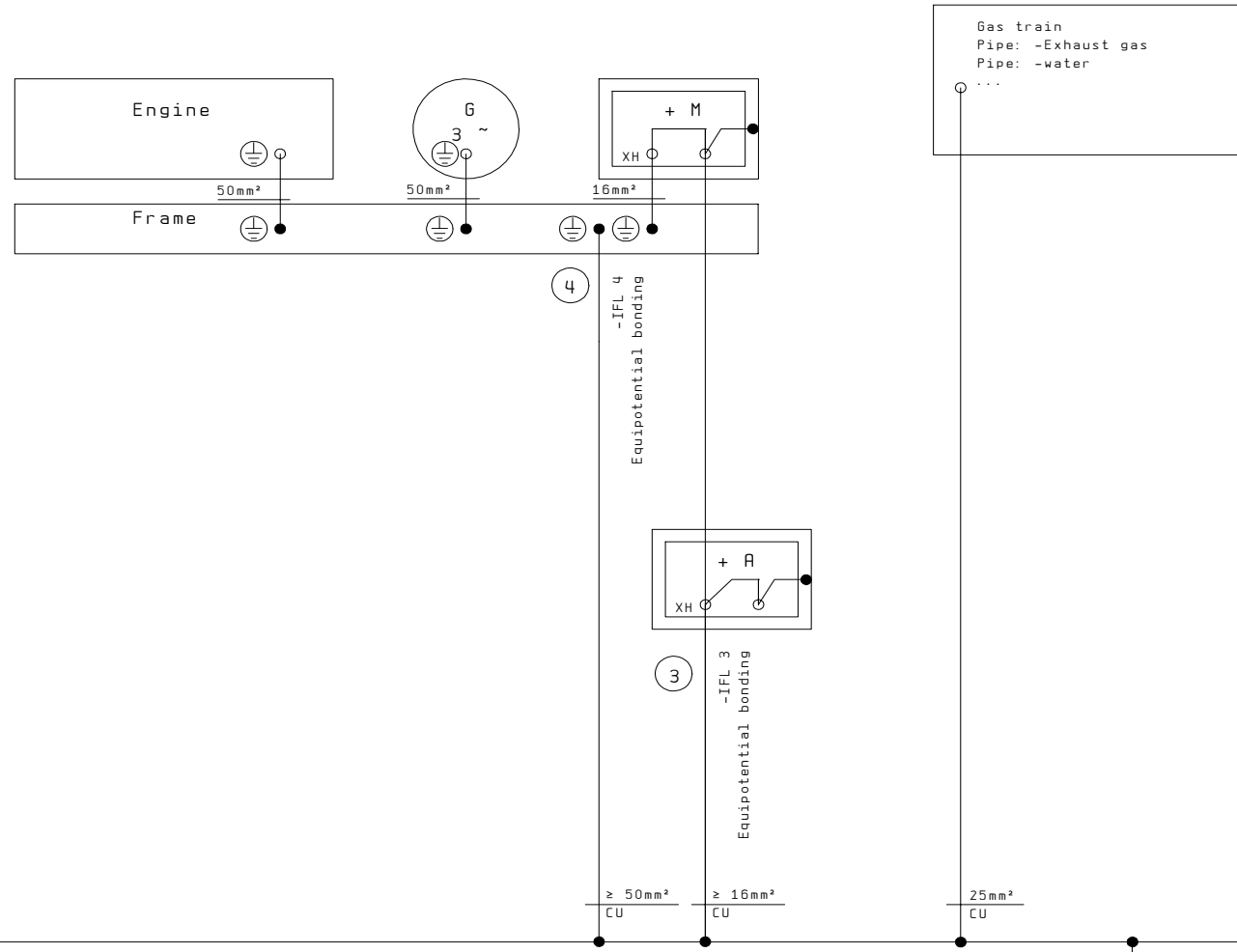

* Cross-sectional area according to IEC 60364-5-54 and national standards.
 Querschnitt nach IEC 60364-5-54 und nationalen Normen.
 Sección conforme IEC 60364-5-54 e normas nacional.
 Section conforme IEC 60364-5-54 et normes nationales.
 Sezione conforme IEC 60364-5-54 e norme nazionale.

		Date	18.01.06	4 x JGS 320 GS-L.L	 Jenbacher gas engines	Potential equalization	SD-Nr. Project	8662
		Desig.	Senfter M.	Nelson Gardens LFG			Suffix	J xxxx
		Print	24.04.12				Wiring diagram	J N795 + U / 13
Modific.	Date	Name	Check	Pieschnik A.	DIR: J:\EPLAN4\VP\ANL\BEN\WXXX\N7XX\JN795.P	KW 05 - 2011	EPLAN 5	

+A1
Module control panel

Connection to BMS/PCS

400

DIANE. XT

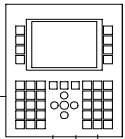

DIANE WIN

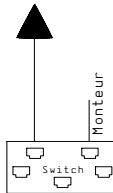

Module interface cubicle

Ignition

IC
92x

CAN

CAN

X2X

X2X

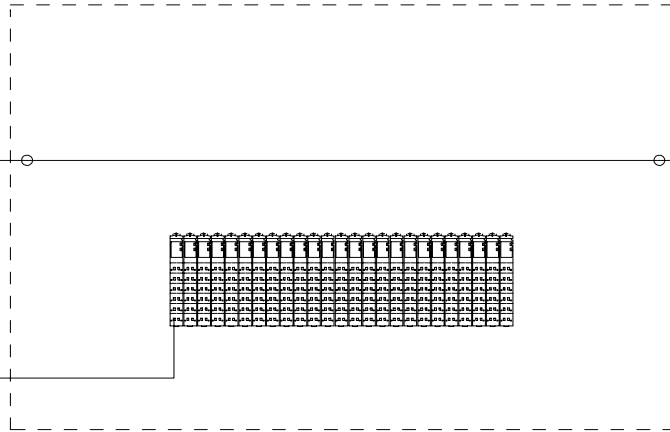
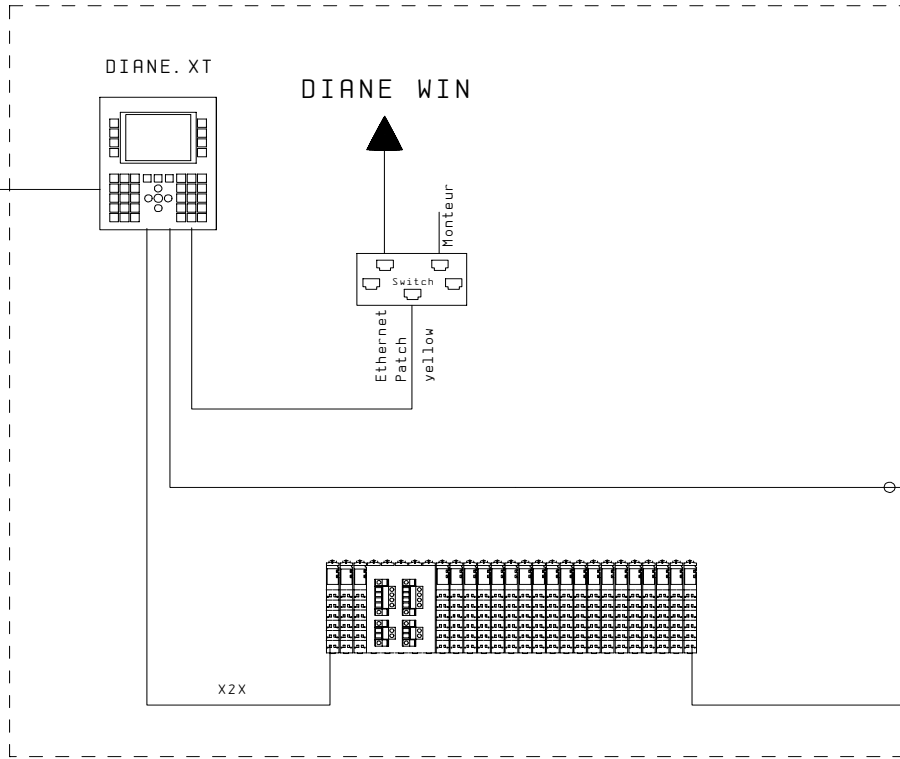

		Date	18.01.06	4 x JGS 320 GS-L.L	 Jenbacher gas engines	SD-Nr. Project	8662			
		Desig.	Senfter M.	Nelson Gardens LFG		Bus diagram	Suffix			
		Print	24.04.12				Wiring diagram	J N795 + U	/	14
Modific.	Date	Name	Check	Pieschnik A.	DIR: J:\EPLAN4\VP\ANL\BEN\WXXX\N7XX\JN795.P	KW 47 - 2010	EPLAN 5			

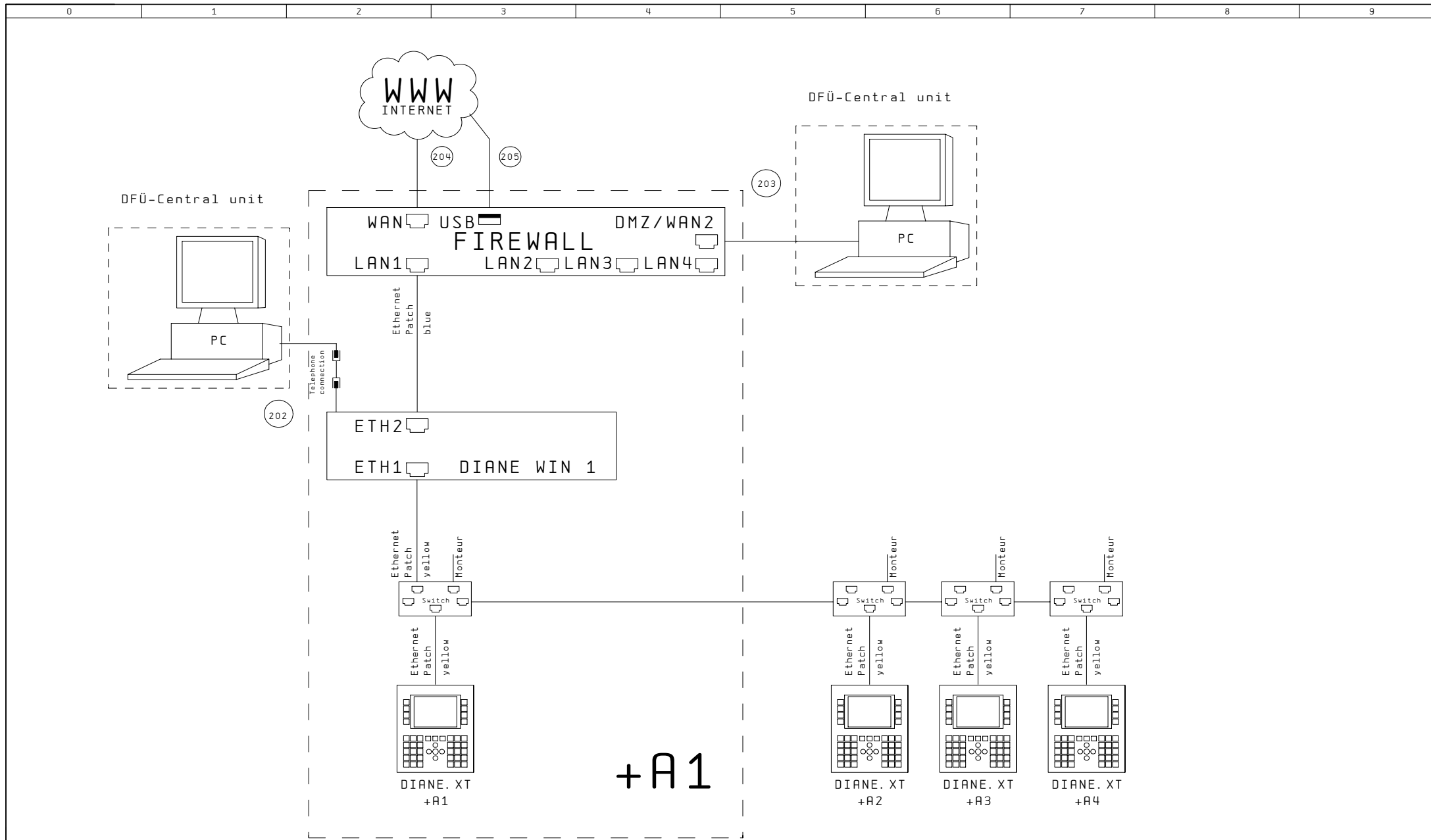

		Date	18.01.06	4 x JGS 320 GS-L.L	 Jenbacher gas engines	Bus diagram	SD-Nr.	8662
		Desig.	Senfter M.	Nelson Gardens LFG			Suffix	J xxxx
		Print	24.04.12				Wiring diagram	J N795 + U / 15
Modific.	Date	Name	Check	Pieschnik A.	DIR: J:\EPLAN4\VP\ANL\AGEN\WXXX\N7XX\JN795.P	KW 40 - 2011	EPLAN 5	

Computer: at the customer

MODBUS-RTU Master

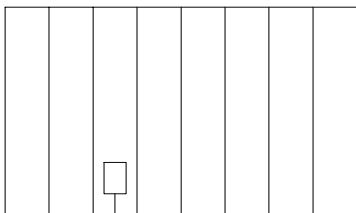

Transmission procedure = MODBUS-RTU-Protocol

RS 485 Bus cable

-SSL 400
400

Limit of delivery: GE Jenbacher
Busterminal Module control panel

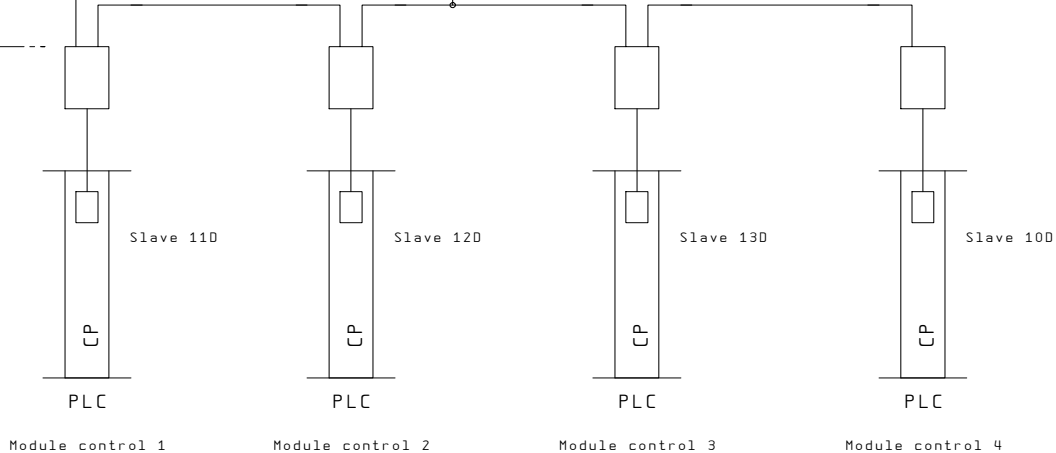

CP = Communications processor

		Date	18.01.06	4 x JGS 320 GS-L.L	 Jenbacher gas engines	MODBUS-RTU	SD-Nr. Project	8662
		Desig.	Senfter M.	Nelson Gardens LFG			Suffix	J xxxx
		Print	24.04.12				Wiring diagram	J N795 + U / 16
Modific.	Date	Name	Check	Pieschnik A.	DIR: J:\EPLAN4\VP\ANL\BEN\WXXX\N7XX\JN795.P	KW 40 - 2011	EPLAN 5	

Over view Software

DIA. NE WIN:
WINSERVER 1

File:

















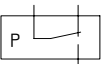

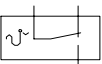









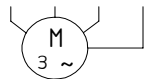

N795

Module control

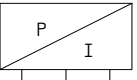
RPS V3.2x

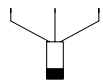
CPU	Enable	Overview	Name	Application
M01 (0B)	<input checked="" type="checkbox"/>	<input checked="" type="checkbox"/>	M01	N795W_A ▾
M02 (0C)	<input checked="" type="checkbox"/>	<input checked="" type="checkbox"/>	M02	N795W_A ▾
M03 (0D)	<input checked="" type="checkbox"/>	<input checked="" type="checkbox"/>	M03	N795W_A ▾
M04 (0E)	<input checked="" type="checkbox"/>	<input checked="" type="checkbox"/>	M04	N795W_A ▾
M05 (0F)	<input type="checkbox"/>	<input type="checkbox"/>	M05	0000W_A ▾
M06 (10)	<input type="checkbox"/>	<input type="checkbox"/>	M06	0000W_A ▾
M07 (11)	<input type="checkbox"/>	<input type="checkbox"/>	M07	0000W_A ▾
M08 (12)	<input type="checkbox"/>	<input type="checkbox"/>	M08	0000W_A ▾
M09 (13)	<input type="checkbox"/>	<input type="checkbox"/>	M09	0000W_A ▾
M10 (14)	<input type="checkbox"/>	<input type="checkbox"/>	M10	0000W_A ▾
M11 (15)	<input type="checkbox"/>	<input type="checkbox"/>	M11	0000W_A ▾
M12 (16)	<input type="checkbox"/>	<input type="checkbox"/>	M12	0000W_A ▾
M13 (17)	<input type="checkbox"/>	<input type="checkbox"/>	M13	0000W_A ▾
M14 (18)	<input type="checkbox"/>	<input type="checkbox"/>	M14	0000W_A ▾
M15 (19)	<input type="checkbox"/>	<input type="checkbox"/>	M15	0000W_A ▾
M16 (1A)	<input type="checkbox"/>	<input type="checkbox"/>	M16	0000W_A ▾
S01 (1F)	<input type="checkbox"/>		S01	0000W_ST ▾
Overview	<input checked="" type="checkbox"/>		ALL	N795W_Z ▾

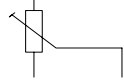
		Date	18.01.06	4 x JGS 320 GS-L.L	 Jenbacher gas engines	Over view Software	SD-Nr. Project	8662
		Desig.	Senfter M.	Nelson Gardens LFG			Suffix	J xxxx
		Print	24.04.12				Wiring diagram	J N795 + U / 17
Modific.	Date	Name	Check	Pieschnik R.	DIR: J:\EPLAN4\P\ANL\GEN\WXXX\N7XX\JN795.P	KW 05 - 2011	EPLAN 5	

0	1	2	3	4	5	6	7	8	9
	NO Contact		Emergency push button extern (interface)		coil for relay/ contactor				
	NC Contact		flow switch NC extern (interface)		coil for coupling relay				
	push button NO		pressure switch COC extern (interface)		electromagnetic valve				
	push button NC		temperature switch COC extern (interface)		terminal				
	camshaft switch lockable NO		miniature circuit breaker		fuse clip				
	Emergency push button		fuse		diode				
	temperature switch NC		temperature sensor thermo couple		three-phase motor				
	pressure switch NO		temperature sensor PT100		battery				
	pressure switch NC		temperature sensor PTC		measuring transducer (pressure/current)				
	NO Contact extern (interface)		resistor		pick up				
	NC Contact extern (interface)		potentiometer		coil				

		Date	18.01.06	4 x JGS 320 GS-L.L	 Jenbacher gas engines	Legend of Symbols	SD-Nr. Project	8662
		Desig.	Senfter M.	Nelson Gardens LFG			Suffix	J K620
		Print	24.04.12				Wiring diagram	J N795 + U / 18
Modific.	Date	Name	Check	Pieschnik A.	DIR: J:\EPLAN4\VP\ANL\BEN\WXXX\N7XX\JN795.P	KW 05 - 2011	EPLAN 5	

CONVERSION TABLE:

AWG Number	dia. inch	dia. mm	mm ²
6/0 = 000000	0,58	14,73	170,30
5/0 = 00000	0,517	13,12	135,10
4/0 = 0000	0,46	11,7	107
3/0 = 000	0,41	10,4	85
2/0 = 00	0,365	9,26	67,4
1/0 = 0	0,325	8,25	53,5
1	0,289	7,35	42,4
2	0,258	6,54	33,6
3	0,229	5,83	26,7
4	0,204	5,19	21,1
5	0,182	4,62	16,8
6	0,162	4,11	13,3
7	0,144	3,66	10,5
8	0,128	3,26	8,36
9	0,144	2,91	6,63
10	0,102	2,59	5,26
11	0,0907	2,30	4,17
12	0,0808	2,05	3,31
13	0,072	1,83	2,62
14	0,0641	1,63	2,08
15	0,0571	1,45	1,65
16	0,0571	1,45	1,65
17	0,0453	1,15	1,04
18	0,0403	1,02	0,823
19	0,0359	0,912	0,653
20	0,032	0,812	0,518
21	0,0285	0,723	0,41
22	0,0253	0,644	0,326
23	0,0226	0,573	0,258
24	0,0201	0,511	0,205
25	0,0179	0,455	0,162
26	0,0159	0,405	0,129
27	0,0142	0,361	0,102
28	0,0126	0,321	0,081
29	0,0113	0,286	0,0642
30	0,01	0,255	0,0509
31	0,00893	0,227	0,0404
32	0,00795	0,202	0,0320
33	0,00708	0,180	0,0254
34	0,00631	0,160	0,0201
35	0,00562	0,143	0,0160
36	0,00500	0,127	0,0127
37	0,00445	0,113	0,0100
38	0,00397	0,101	0,00797
39	0,00353	0,0897	0,0063
40	0,00314	0,0799	0,00501

Single Line Diagram

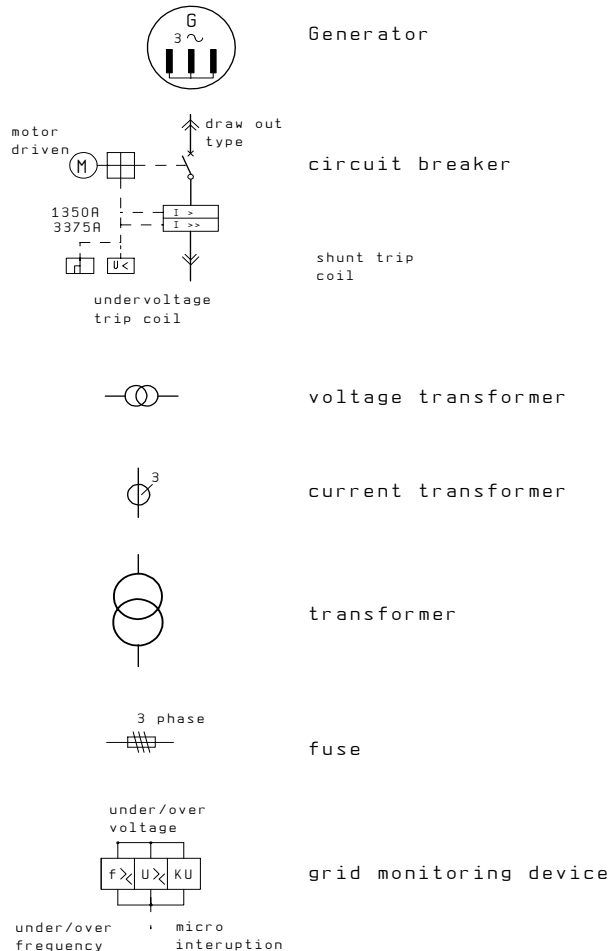

- LED
- A-meter
- volt meter
- device
- earth
- protection earth
- ground
- shield
- feeding extern (interface)
- interface see Interface List

LABELING

IFL.. = Interface (see Interface List)

NO = Normal open contact

NC = Normal closed contact

COC = change over contact

Date		18.01.06	4 x JGS 320 GS-L.L		Jenbacher gas engines	Legend of Symbols	SD-Nr. Project	8662
Desig.		Senfter M.	Nelson Gardens LFG				Suffix	J xxxx
Print		24.04.12					Wiring diagram	J N795 + U / 19
Modific.	Date	Name	Check	Pieschnik A.	DIR: J:\EPLAN4\VP\ANL\AGEN\WXXX\N7XX\JN795.P	KW 05 - 2011	EPLAN 5	

Requirements for Cablings

ACCORDING NEC, article 310 and 318, as well as,
 TA.NO.: 1000-0505
 The conductors shall be of copper

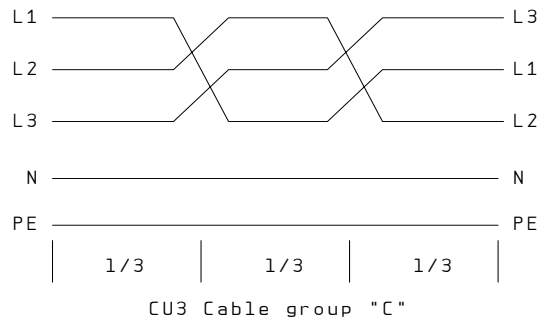

Cable groups:

TI-No-N.: 1000-0505

CU1 Cable group A : Shielded analog cables

Cables unshielded AC/DC ≤60 V

Cable shielded AC/DC ≤277 V

L62 Cable group B : Cable unshielded AC/DC >60 V, ≤277 V

L63 Cable group C : Cable unshielded AC/DC >277 V, ≤1 kV

Cables shielded AC >230 V, ≤1 kV

Bus cables must be laid separately !

D=Cable diameter

Cable configuration according NEC 318-11-b.



Metallic cable tray

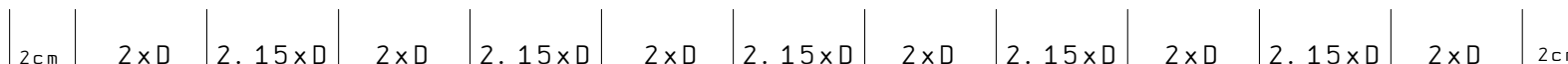

Cable group CU3-"C"

Cable group CU2-"B"

Cable group CU1-"A"

Bus cable

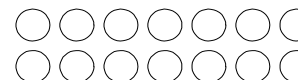
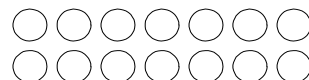
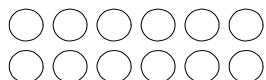

(REMOTEBUS, ...)



Metallic cable tray

>100mm, 4"

>100mm, 4"

>100mm, 4"

Date		18.01.06		4 x JGS 320 GS-L.L		Jenbacher gas engines	Requirements for Cablings		SD-Nr. Project	8662	
Desig.		Senfter M.		Nelson Gardens LFG			Requirements NEC		Suffix	J N289	
Print		24.04.12		DIR: J:\EPLAN4\VP\ANL\BEN\WXXX\N7XX\JN795.P			KW 05 - 2011		Wiring diagram	J N795 + U / 20	
Modific.	Date	Name	Check	Pieschnik A.		EPLAN 5					

Cable GE Jenbacher

Cable GE Jenbacher Electric wiring diagram	VDE / IEC			USA	Ital. CEI 20-22	Spain
YSLY-OZ	NYSLYö-OZ VDE 250	H05VV5-F. X. .	SiHF Silikon	THWN		RV-K 0,6/1KV
YSLY-JZ	NYSLYö-JZ VDE 250	H05VV5-F. G. .	SiHF Silikon	THWN		RV-K 0,6/1KV incl. PE
YSLCY-OZ	NYSLCYö-OZ VDE 250	H05VVC4V5-K. X. .		1PR16S		RV-K 0,6/1KV apantallado
YSLCY-JZ	NYSLCYö-JZ VDE 250	H05VVC4V5-K. G. .		1PR16S		RV-K 0,6/1KV incl PE y apantallado
NY Y	NY Y 1x185 rm 0,6/1KV-VDE 271	NY Y 1x185 rm 0,6/1KV -VDE 271		THWN up to 600V	NIVVK	RV-K 0,6/1KV
H07RNF		H07RNF VDE 0282			H07RNF	H07RNF
H07V-K		H07V-K VDE 0281			H07V-K	H07V-K
NICRNI-gesch. für Thermolemente	90 N ... DIN IEC 584			ANSI MC 96.1 for thermocouples	90 N ... DIN IEC 584	90 N ... DIN IEC 584
NSGAFÖU-3kV	NSGAFÖU-3kV			MV-90 >5KV		
NY Y 0,6/1KV	all Cable flexibel power cable at a minimum multi core				Tutti i cavi con fili fini cavi di potenza almeno di fino multipolare	Todos los cables con hilos finos cables de potencia por lo menos de hilos multiples
Cable for Middle voltage generator (>1kV)	Cable according Generator-Manufacturer z.B. Siemens PROTOLON-NTMCGCWÖU			see Technical specification of the control N795 4440 00 Part 4		

20

22

		Date	18.01.06	4 x JGS 320 GS-L.L	 Jenbacher gas engines	Cable with DIANE	SD-Nr. Project	8662
		Desig.	Senfter M.	Nelson Gardens LFG			Suffix	J xxxx
		Print	24.04.12				Wiring diagram	J N795 + U / 21
Modific.	Date	Name	Check	Pieschnik A.	DIR: J:\EPLAN4\VP\ANL\BEN\WXXX\N7XX\JN795.P	KW 05 - 2011	EPLAN 5	

Over view cables

+a-W. b xxx. c ddd-e f

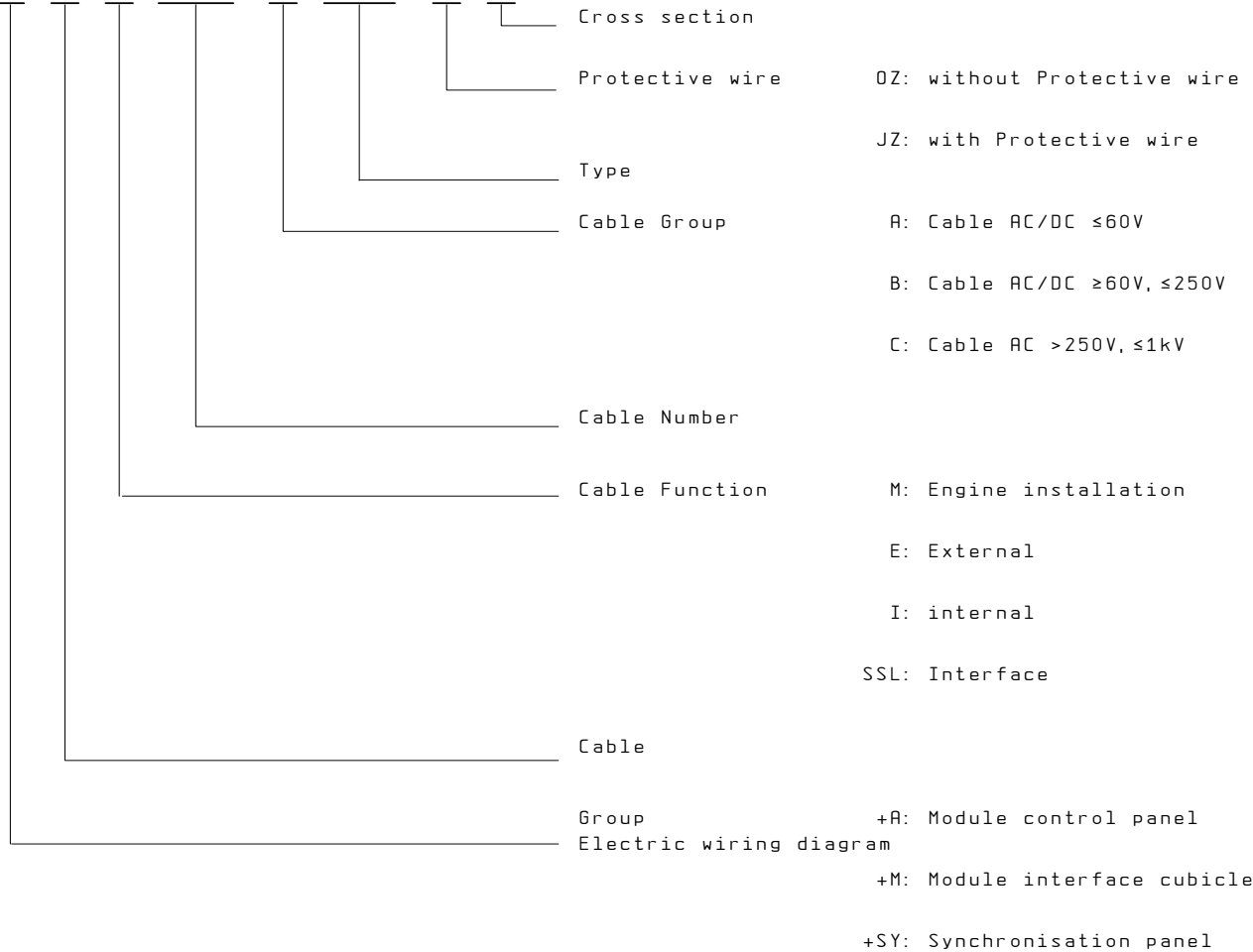

example

example: Cable internal

+M-W. I100. A YSLCY-OZ 2x1,5mm²

example: Engine installation

+M-W. M100. A YSLC-JZ 3x1,5mm²

example: Cable External

+M-W. E100. A YSLCY-JZ 5x2,5mm²

example: Interfaces

+M-W. SSL100

Over view cables

Cable	Type	Wire	mm2	from	to	Comment	Page
+G1-W. SSL1		5/PE	-	+G1-X	+P1-SSL1	See TA 1100-0112	+G1/4.2
+G1-W. SSL2		1/PE	-	+G1-X	+P1-SSL2	-IFL 2 Service grounding	+G1/4.1
+G1-W. SSL4	H07V-K	1/PE	50	+P1-SSL4	+G1-4G1	-IFL 4 Potential equalization	+G1/4.0
+G1-W. M190. A	YSLCY-JZ	18/PE+SS	1.5	+G1-X	+M1-XS	Windings temperature in U	+G1/5.0
+G1-W. M194. A	YSLY-OZ	2	1.5	+G1-XDECS	+M1-X	Failure	+G1/6.3
+G1-W. M196. B	YSLY-OZ	2	1.5	+G1-XDECS	+M1-XE	Cos-Phi-Controller	+G1/6.5
+G1-W. M197. B	YSLY-OZ	2	1.5	+G1-XDECS	+M1-XE	Failure	+G1/6.4
+G1-W. M198. A	YSLCY-OZ	2+SS	1.5	+G1-XDECS	+M1-56T1	Excitation voltage	+G1/6.0
+G1-W. M199. B	YSLY-JZ	5/PE	1.5	+G1-XDECS	+M1-XE	Deexcitation	+G1/6.1
+G1-W. M200. B	YSLY-JZ	3/PE	1.5	+E1-XHK	+G1-X	Anti condensation heater	+G1/7.4
+G1-W. M202. A	YSLCY-OZ	2+SS	1.5	+G1-XDECS	+M1-XS	AUX. ADJUST	+G1/6.7
+G1-W. M203. B	YSLY-OZ	2	1.5	+G1-XDECS	+M1-XE	Selection SY	+G1/6.7
+M1-W. E5. A	NSGAFÖU	1	120	+E1-11M2	+P1-11C1	Battery +	+M1/11.2
+M1-W. E6. A	NSGAFÖU	1	120	+E1-11W1	+P1-11C2	Battery -	+M1/11.3
+M1-W. E8. A	YSLY-JZ	5/PE	10	+M1-X	+A1-X	Module control panel	+M1/9.1
+M1-W. E10. A	X2X	4+SS	0.34	+M1-17K1	+A1-27K2	Delivery GE Jenbacher	+M1/24.1
+M1-W. E12. B	YSLY-OZ	2	1.5	+M1-XE	+A1-XE	Voltage matching	+M1/55.2
+M1-W. E13. C	H07V-K	1/PE	16	+M1-XH	+A1-XH	Equipotential bonding Module interface	+M1/8.5
+M1-W. E20. A	YSLY-OZ	2	1.5	+M1-X	+P1-44B1	Gas pressure low Gas train 1	+M1/44.0
+M1-W. E25. A	YSLY-JZ	4/PE	1.5	+M1-X	+P1-51K1	Gas safety device 1	+M1/51.1
+M1-W. E30. A	YSLY-JZ	4/PE	2.5	+M1-X	+P1-52M1	Gas valve 1 Gas train 1	+M1/52.1
+M1-W. M16. A	YSLCY-OZ	3+SS	0.75	+M1-XS	+E1-48B33	Gas engine: Water return Temperature	+M1/48.4
+M1-W. M101. C	YSLY-JZ	5/PE	1.5	+E1-XHK	+E1-10M1	ÖLFLEX UL	+M1/10.1
+M1-W. M103. C	YSLY-JZ	5/PE	2.5	+E1-XHK	+E1-10E1	ÖLFLEX UL	+M1/10.2
+M1-W. M109. A	YSLY-JZ	3/PE	4	+M1-X	+E1-12M3	Prelubrication oil pump Cool down oilpump	+M1/12.4
+M1-W. M112. A	YSLY-OZ	2	1.5	+M1-X	+E1-42B31	Vibration Alarm	+M1/42.6
+M1-W. M114. A	YSLY-OZ	2	1.5	+M1-X	+E1-43B32	Oil differential pressure high	+M1/43.1
+M1-W. M117. A	YSLCY-OZ	3+SS	1.5	+M1-XS	+E1-40B23	Supercharge pressure	+M1/40.3
+M1-W. M118. A	PT100	3+SS	0.25	+M1-XS	+E1-41B26	Fuel mixture temperature	+M1/41.2
+M1-W. M119. A	YSLCY-OZ	3+SS	0.75	+M1-XS	+E1-41B27	Oil temperature	+M1/41.3
+M1-W. M120. A	YSLCY-OZ	3+SS	0.75	+M1-XS	+E1-41B28	Engine jacket water temperature	+M1/41.4
+M1-W. M121. A	YSLCY-OZ	3+SS	0.75	+M1-XS	+E1-40B21	Oil pressure	+M1/40.0
+M1-W. M122. A	YSLCY-OZ	3+SS	0.75	+M1-XS	+E1-40B22	Jacket water pressure	+M1/40.1
+M1-W. M123. C	YSLY-JZ	3/PE	1.5	+E1-XHK	+M1-XH	ÖLFLEX UL	+M1/10.6
+M1-W. M124. C	YSLY-JZ	4/PE	1.5	+E1-XHK	+M1-XH	ÖLFLEX UL	+M1/10.4

		Date	18.01.06	4 x JGS 320 GS-L.L		 Jenbacher gas engines	Over view cables		SD-Nr. Project	8662
		Desig.	Senfter M.	Nelson Gardens LFG					Suffix	
		Print	24.04.12						Wiring diagram	
Modific.	Date	Name	Check	Pieschnik A.	DIR: J:\EPLAN4\VP\ANL\BEN\WXXX\N7XX\JN795.P		EPLAN 5		J N795 + U	/ 23

Over view cables

Cable	Type	Wire	mm2	from	to	Comment	Page
+M1-W. M130. A	YSLY-JZ	3/PE	2.5			Ignition	
		3/PE	2.5	+M1-X	+E1-58K1	Ignition	+M1/58.2
		3/PE	2.5	+M1-XH	+E1-58K1	Ignition	+M1/58.2
+M1-W. M131. A	YSLY-JZ	5/PE	1.5	+M1-X	+E1-58K1	I	+M1/58.3
+M1-W. M138. A	YSLY-JZ	5/PE	1.5	+M1-X	+E1-42B30	Oil level: Gas engine	+M1/42.3
+M1-W. M139. A	YSLY-OZ	2	1.5	+M1-X	+E1-42M5	Oil valve	+M1/42.0
+M1-W. M148. A	YSLCY-JZ	3/PE+SS	1.5	+M1-XS	+E1-40M4	Mixer position	+M1/40.4
+M1-W. M149. A	YSLY-JZ	5/PE	0.75	+M1-X	+E1-40M4	Air-gas mixer P1	+M1/46.2
+M1-W. M150. A	NICRNIGE	2+SS	0.5	+E1-25B1	+M1-17K2	Cylinder: 1	+M1/25.1
+M1-W. M151. A	NICRNIGE	2+SS	0.5	+E1-25B2	+M1-17K2	2	+M1/25.2
+M1-W. M152. A	NICRNIGE	2+SS	0.5	+E1-25B3	+M1-17K2	3	+M1/25.4
+M1-W. M153. A	NICRNIGE	2+SS	0.5	+E1-25B4	+M1-17K2	4	+M1/25.5
+M1-W. M154. A	NICRNIGE	2+SS	0.5	+E1-25B5	+M1-17K2	5	+M1/25.7
+M1-W. M155. A	NICRNIGE	2+SS	0.5	+E1-25B6	+M1-17K2	6	+M1/25.8
+M1-W. M156. A	NICRNIGE	2+SS	0.5	+E1-26B7	+M1-17K3	Cylinder: 7	+M1/26.1
+M1-W. M157. A	NICRNIGE	2+SS	0.5	+E1-26B8	+M1-17K3	8	+M1/26.2
+M1-W. M158. A	NICRNIGE	2+SS	0.5	+E1-26B9	+M1-17K3	9	+M1/26.4
+M1-W. M159. A	NICRNIGE	2+SS	0.5	+E1-26B10	+M1-17K3	10	+M1/26.5
+M1-W. M160. A	NICRNIGE	2+SS	0.5	+E1-26B11	+M1-17K3	11	+M1/26.7
+M1-W. M161. A	NICRNIGE	2+SS	0.5	+E1-26B12	+M1-17K3	12	+M1/26.8
+M1-W. M162. A	NICRNIGE	2+SS	0.5	+E1-27B13	+M1-17K4	Cylinder: 13	+M1/27.1
+M1-W. M163. A	NICRNIGE	2+SS	0.5	+E1-27B14	+M1-17K4	14	+M1/27.2
+M1-W. M164. A	NICRNIGE	2+SS	0.5	+E1-27B15	+M1-17K4	15	+M1/27.4
+M1-W. M165. A	NICRNIGE	2+SS	0.5	+E1-27B16	+M1-17K4	16	+M1/27.5
+M1-W. M166. A	NICRNIGE	2+SS	0.5	+E1-27B17	+M1-17K4	17	+M1/27.7
+M1-W. M167. A	NICRNIGE	2+SS	0.5	+E1-27B18	+M1-17K4	18	+M1/27.8
+M1-W. M168. A	NICRNIGE	2+SS	0.5	+E1-28B19	+M1-17K5	Cylinder: 19	+M1/28.1
+M1-W. M169. A	NICRNIGE	2+SS	0.5	+E1-28B20	+M1-17K5	20	+M1/28.2
+M1-W. M170. A	YSLY-OZ	2	1.5	+M1-X	+E1-53M6	Supply Actuator	+M1/53.6
+M1-W. M171. A	YSLCY-OZ	3+SS	0.75	+M1-XS	+E1-53M6	mA Actuator	+M1/53.7
+M1-W. M175. A	LIY-CY	2	0.25	+M1-XS	+E1-40B24	Knocking detector 1	+M1/40.5
+M1-W. M176. A	LIY-CY	2	0.25	+M1-XS	+E1-40B25	Knocking detector 2	+M1/40.6
+M1-W. M181. A	YSLY-OZ	4	1.5	+M1-X	+E1-54M7	Turbo bypass valve 1	+M1/54.0
+M1-W. M182. A	YSLCY-OZ	2+SS	0.75	+M1-XS	+E1-54M7	Turbo bypass valve 1	+M1/54.1
+M1-W. M193. A	YSLCY-OZ	3+SS	0.75	+M1-XS	+E1-41B29	Intake air temperature	+M1/41.5

		Date	18.01.06	4 x JGS 320 GS-L.L		 Jenbacher gas engines	Over view cables	SD-Nr.	8662
		Desig.	Senfter M.	Nelson Gardens LFG				Suffix	
		Print	24.04.12					Wiring diagram	J N795 + U / 24
Modific.	Date	Name	Check	Pieschnik A.	DIR: J:\EPLAN4\VP\ANL\BEN\WXXX\N7XX\JN795.P				
						EPLAN 5			

Over view cables

Cable	Type	Wire	mm2	from	to	Comment	Page
+M1-W. M216. A	Kabelbaum	2	-	+E1-58B34	+E1-58K1	Crankshaft	+M1/58.6
+M1-W. M217. A	Kabelbaum	2	-	+E1-58B35	+E1-58K1	Crankshaft	+M1/58.7
+M1-W. M218. A	Kabelbaum	3	-	+E1-58B36	+E1-58K1	PU1	+M1/58.8
+M1-W. M223. A	Kabelbaum	3	-	+M1-XS	+E1-58K1	Ignition	+M1/58.1
+M1-W. M261. A	NSGAFÖU	1	120	+E1-11M2	+E1-11W1	Battery -	+M1/11.2
+M1-W. M266. A	H07V-K_ws	1	1.5	+M1-X	+E1-11M2	Starter motor	+M1/11.1
+M1-W. M267. A	H07V2-K_rt	1	10	+M1-X	+E1-11M2	Charge	+M1/11.0
+M1-W. M268. A	H07V-K_br	1	10	+M1-X	+E1-11M2	Charge	+M1/11.5
+M1-W. SSL49.9		4/PE	-	+E1-XHK	+P1-SSL49.9	-IFL 49.9 Preheating pump	+M1/10.0
+M1-W. SSL49.11		5/PE	-	+E1-XHK	+P1-SSL49.11	-IFL 49.11 Preheating	+M1/10.1
+M1-W. SSL49.13		4/PE	-	+E1-XHK	+P1-SSL49.13	-IFL 49.13 Supply Charging unit	+M1/10.4
+M1-W. SSL49.15		3/PE	-	+E1-XHK	+P1-SSL49.15	-IFL 49.15 Anti condensation heater	+M1/10.8
+M1-W. SSL49.16		3/PE	-	+E1-XHK	+P1-SSL49.16	-IFL49.16 Supply cooling system	+M1/10.5
+A1-W. E4. A	YSLY-JZ	7/PE	2.5	+G1-X	+A1-XE	Generator current	+A1/14.0
+A1-W. I2. A	CAN-BUSKABEL	4+SS	-	+A1-XS	+A1-43X1	CAN-Bus	+A1/46.2
+A1-W. I4. A	X2X	4+SS	0.34	+A1-23K1	+A1-43X2	violet	+A1/43.8
+A1-W. SSL3		1/PE	-	+A1-XH	+A1-SSL3	-IFL 3 Equipotential bonding	+A1/20.1
+A1-W. E33. A	CAN-BUSKABEL	4+SS	-	+M1-XS	+A1-XS	Delivery GE Jenbacher	+A1/46.1
+A1-W. E71. A	MODBUS	2+SS	-	+A1-45K1	+A2-45X1	MODBUS	+A1/45.4
+A1-W. E81. A	YSLY-JZ	5/PE	2.5	+M1-X	+A1-X	Emergency stop	+A1/52.1
+A1-W. I13. A	Ethernet	8+SS	-	+A1-43K1	+A1-44K1	Switch --> PP450	+A1/44.1
+A1-W. I20. A	Kabelbaum	4	-			-IFL 400 MODBUS	
		4	-	+A1-3	+A1-45K1	-IFL 400 MODBUS	+A1/45.4
		4	-	+A1-5	+A1-45K1	MODBUS	+A1/45.4
		4	-	+A1-6	+A1-45K1	MODBUS	+A1/45.4
		4	-	+A1-8	+A1-45K1	MODBUS	+A1/45.4
+A1-W. SSL13		5/PE	-	+A1-XE	+P1-SSL13	-IFL 13 Generator voltage	+A1/14.4
+A1-W. SSL14		3	-	+P1-SSL14	+A1-54K1	-IFL 14 ready for Automatic demand	+A1/54.0
+A1-W. SSL15		2	-	+A1-X	+P1-56S5	-IFL 15 Demand	+A1/56.1
+A1-W. SSL17		3	-	+P1-SSL17	+A1-54K2	-IFL 17 Module demanded	+A1/54.1
+A1-W. SSL19		2	-	+A1-X	+P1-56S6	-IFL 19 Release Auxiliaries	+A1/56.2
+A1-W. SSL20		3	-	+P1-SSL20	+A1-54K3	-IFL 20 Operation / Engine runs	+A1/54.1
+A1-W. SSL21		3	-	+P1-SSL21	+A1-54K4	-IFL 21 General alarm shut down	+A1/54.2
+A1-W. SSL22		3	-	+P1-SSL22	+A1-54K5	-IFL 22 General alarm warn	+A1/54.3
+A1-W. SSL23		2	-	+A1-XE	+P1-SSL23	-IFL 23 Emergency stop	+A1/53.1

Date		18.01.06		4 x JGS 320 GS-L.L		 Jenbacher gas engines	Over view cables		SD-Nr. Project	8662		
Desig.		Senfter M.		Nelson Gardens LFG					Suffix			
Print		24.04.12							Wiring diagram		J N795 + U / 25	
Modific.	Date	Name	Check	Pieschnik A.		DIR: J:\EPLAN4\PLANLAGE\WXXX\N7XX\JN795.P		EPLAN 5				

Over view cables

Cable	Type	Wire	mm2	from	to	Comment	Page
+A1-W. SSL27		2	-	+A1-XS	+P1-SSL27	-IFL27 External Decrease load	+A1/39.2
+A1-W. SSL28		2	-	+A1-XS	+P1-SSL28	-IFL 28 External Set point power	+A1/39.0
+A1-W. SSL29		2	-	+A1-XS	+P1-SSL29	-IFL 29 Generator active power	+A1/41.1
+A1-W. SSL30		3	-	+P1-SSL30	+A1-54K6	-IFL 30 Generator Energy	+A1/54.4
+A1-W. SSL39		2	-	+A1-X	+P1-52S1	-IFL 39 Emergency stop	+A1/52.3
+A1-W. SSL41		2	-	+A1-X	+P1-55S4	-IFL 41 Fire alarm	+A1/55.3
+A1-W. SSL75		5/PE	-	+A1-XE	+P1-SSL75	-IFL 75 Busbar voltage	+A1/12.0
+A1-W. SSL76		2	-	+A1-XE	+P1-SSL76	-IFL 76 opening failure Generator circuit breaker	+A1/53.4
+A1-W. SSL79		4	-			-IFL 79 GCB Under voltage trip coil	
		4	-	+A1-XCB	+P1-SSL79	-IFL 79 GCB Under voltage trip coil	+A1/51.6
+A1-W. SSL80		4	-	+A1-XE	+P1-SSL79	-IFL 79 Command Under voltage trip coil	+A1/53.2
+A1-W. SSL81		2	-	+A1-X	+P1-58S11	-IFL 80 Generator circuit breaker closed	+A1/58.1
+A1-W. SSL82		2	-	+A1-X	+P1-58S12	-IFL 81 Generator circuit breaker open	+A1/58.2
+A1-W. SSL83		2	-	+A1-X	+P1-58S13	-IFL 82 Generator circuit breaker ready	+A1/58.3
+A1-W. SSL84		2	-	+A1-X	+P1-58S14	-IFL 83 GCB C.B. racked in	+A1/58.4
+A1-W. SSL85		2	-	+A1-XE	+P1-58S15	-IFL 84 GCB Overload Short circuit	+A1/58.5
+A1-W. SSL109		2	-	+A1-X	+P1-SSL85	-IFL 85 Mains failure	+A1/53.3
+A1-W. SSL400	MODBUS	2+SS	-	+A1-X	+P1-58S17	-IFL 109 Mains OK	+A1/58.7
+A1-W. SSL18.1		2	-	+P1-SSL400	+A1-45K1	-IFL 400 MODBUS	+A1/45.4
+A1-W. SSL18.2		2	-	+A1-XE	+P1-SSL18	-IFL 18 Demand Auxiliaries	+A1/53.0
+A1-W. SSL27.1		2	-	+A1-XE	+P1-SSL18	-IFL 18 Demand Auxiliaries	+A1/53.1
+A1-W. SSL40.1		2	-	+A1-X	+P1-56S7	-IFL 27.1 Release Grid Import/Export Controller	+A1/56.3
+A1-W. SSL40.2		2	-	+A1-X	+P1-55S2	-IFL 40.1 Gas prealarm	+A1/55.1
+A1-W. SSL49.7		2	-	+A1-X	+P1-55S3	-IFL 40.2 Gas alarm	+A1/55.2
+A1-W. SSL54.1		2	-	+A1-XE	+P1-SSL49.7	-IFL 49.7 Demand Preheating pump	+A1/53.4
+A1-W. SSL54.2		2	-	+A1-X	+P1-49B3	-IFL 54.1 Pressure low: Inter cooling water	+A1/49.0
+A1-W. SSL54.3		2	-	+A1-XE	+P1-SSL54.2	-IFL 54.2 Demand Fuel mixture cooling water pump	+A1/53.7
+A1-W. SSL55.1		2	-	+A1-X	+P1-57S7	-IFL 54.3 Operation Fuel mixture cooling water pump	+A1/57.2
+A1-W. SSL55.6		2	-	+A1-X	+P1-57S8	-IFL 55.1 Pressure: Cooling circuit low.	+A1/57.3
+A1-W. SSL56.1		2	-	+A1-XE	+P1-SSL55.6	-IFL 55.6 Demand Dump radiator	+A1/53.7
		5	-			-IFL 56.1 Room temperature	
		5	-	+A1-XS	+P1-47B2	-IFL 56.1 Room temperature	+A1/47.7
		5	-	+A1-X	+P1-57S10	-IFL 56.1 Room temperature high	+A1/57.5
+A1-W. SSL60.1		2	-	+A1-X	+P1-59S18	-IFL 60.1 Release Gas engines	+A1/59.1
+A1-W. SSL60.2		2	-	+A1-X	+P1-59S19	-IFL 60.2 Disable CH4 Signal	+A1/59.2

Date		18.01.06		4 x JGS 320 GS-L.L		 Jenbacher gas engines	Over view cables		SD-Nr. Project	8662		
Desig.		Senfter M.		Nelson Gardens LFG					Suffix			
Print		24.04.12		DIR: J:\EPLAN4\VP\ANL\BEN\WXXX\N7XX\JN795.P			EPLAN 5		Wiring diagram	J N795 + U		/ 26

Over view cables

Cable	Type	Wire	mm2	from	to	Comment	Page
+A1-W. SSL60.5		2	-	+A1-X	+P1-59S20	-IFL 60.5 Calibration CH4: activ	+A1/59.3
+A1-W. SSL61.2		2	-	+A1-XS	+P1-SSL61.2	-IFL 61.2 Content:CH4 Collect line	+A1/39.4
+A1-W. SSL78.1		2	-	+A1-XCB	+P1-SSL78	-IFL 78 GCB Switch on coil	+A1/51.3
+A1-W. SSL78.2		2	-	+A1-XCB	+P1-SSL78	-IFL 78 GCB Shunt trip coil	+A1/51.4
+A1-W. SSL84.1		2	-	+A1-X	+P1-58S16	-IFL 84.1 Generator: Protection tripped	+A1/58.6
+A1-W. SSL49.10		2	-	+A1-XE	+P1-SSL49.10	-IFL 49.10 Demand Preheating	+A1/53.5
+A1-W. SSL49.14		2	-	+A1-XE	+P1-SSL49.14	-IFL 49.14 Demand Generator Anti condensation heater	+A1/53.6
+A1-W. SSL55.18		2	-	+A1-X	+P1-57S9	-IFL 55.18 Failure Dump radiator	+A1/57.4
+DF1-W. I1. A	Kabelbaum	2	0.75	+DF1-4K1	+DF1-4T1	Firewall	+DF1/4.2
+DF1-W. I10. A	Ethernet	8+SS	-	+A1-44K1	+DF1-3K1	DIANE XT	+DF1/3.3
+DF1-W. I101. A	Ethernet	8+SS	-	+DF1-3K1	+DF1-4K1	WINSERVER 1	+DF1/4.8
+DF1-W. SSL202		1	-	+P1-SSL202	+DF1-3A1	-IFL 202 Telephone connection	+DF1/3.5
+DF1-W. SSL203		1	-	+P1-SSL203	+DF1-4K1	-IFL 203 -->DFÜ Central unit	+DF1/4.7
+DF1-W. SSL204		1	-	+P1-SSL204	+DF1-4K1	-IFL 204 INTERNET Connection	+DF1/4.6
+DF1-W. SSL205		1	-	+P1-SSL205	+DF1-4K1	-IFL 205 INTERNET Connection	+DF1/4.5

		Date	18.01.06	4 x JGS 320 GS-L.L	 Jenbacher gas engines	Over view cables	SD-Nr. Project	8662
		Desig.	Senfter M.	Nelson Gardens LFG			Suffix	
		Print	24.04.12					
Modific.	Date	Name	Check	Pieschnik A.	DIR: J:\EPLAN4\P\ANL\GEN\WXXX\N7XX\JN795.P	EPLAN 5	Wiring diagram	J N795 + U / 27

Designation of the components:
Electric wiring diagram - Technical schema

Die Nummern in der Bauteilzuordnung
beziehen sich auf die Nummern in der
Schnittstellenliste J N795
und technischem Schema J N795 00 03

The numbers in the part reference list
are in relation with the numbers in
the Interface-list J N795
and the Technical schema J N795 00 03

+U/27

2

		Date	18.01.06	4 x JGS 320 GS-L.L	 Jenbacher gas engines	Part reference list	SD-Nr. Project	8662
		Desig.	Senfter M.	Nelson Gardens LFG			Suffix	J xxxx
		Print	24.04.12				Wiring diagram	J N795 + B / 1
Modific.	Date	Name	Check	Pieschnik R.	DIR: J:\EPLAN4\P\ANL\BEN\XXXX\N7XX\JN795.P	KW 12 - 2012	EPLAN 5	

0	1	2	3	4	5	6	7	8	9
Abbreviation	Page	Elec. wiring diagram Number	Denomination	Comment					
E.00-M-001 [01]	+M1/11.1	+E1-11M2	Engine (Engine block-Engine)	Starter					
E.00-AI-101 [02]	+M1/40.5	+E1-40B24	Vibration sensor (Engine block-Engine)	Knock sensor					
E.00-AI-101 [16]	+M1/40.7	+E1-40B25	Vibration sensor (Engine block-Engine)	Knock sensor					
E.00-USZ-003	+M1/58.0	+E1-58K1	Ignition (Engine block-Engine)	IC920					
E.00-SI-001	+M1/58.6	+E1-58B34	Pickup (Engine block-Engine)	Crankshaft					
E.00-SI-002	+M1/58.7	+E1-58B35	Pickup (Engine block-Engine)	Crankshaft (Reset)					
E.00-SI-005	+M1/58.8	+E1-58B36	Pickup (Engine block-Engine)	Camshaft					
E.01-M-001	+M1/40.4	+E1-40M4	Engine (Fuel gas-Engine)	Gas mixer					
E.02-TI-001 [01]	+M1/25.1	+E1-25B1	Temperature control (Exhaust gas-Engine)	Exhaust gas outlet cylinder head					
E.02-TI-001 [02]	+M1/25.2	+E1-25B2	Temperature control (Exhaust gas-Engine)	Exhaust gas outlet cylinder head					
E.02-TI-001 [03]	+M1/25.4	+E1-25B3	Temperature control (Exhaust gas-Engine)	Exhaust gas outlet cylinder head					
E.02-TI-001 [04]	+M1/25.5	+E1-25B4	Temperature control (Exhaust gas-Engine)	Exhaust gas outlet cylinder head					
E.02-TI-001 [05]	+M1/25.7	+E1-25B5	Temperature control (Exhaust gas-Engine)	Exhaust gas outlet cylinder head					
E.02-TI-001 [06]	+M1/25.8	+E1-25B6	Temperature control (Exhaust gas-Engine)	Exhaust gas outlet cylinder head					
E.02-TI-001 [07]	+M1/26.1	+E1-26B7	Temperature control (Exhaust gas-Engine)	Exhaust gas outlet cylinder head					
E.02-TI-001 [08]	+M1/26.2	+E1-26B8	Temperature control (Exhaust gas-Engine)	Exhaust gas outlet cylinder head					
E.02-TI-001 [09]	+M1/26.4	+E1-26B9	Temperature control (Exhaust gas-Engine)	Exhaust gas outlet cylinder head					
E.02-TI-001 [10]	+M1/26.5	+E1-26B10	Temperature control (Exhaust gas-Engine)	Exhaust gas outlet cylinder head					
E.02-TI-001 [11]	+M1/26.7	+E1-26B11	Temperature control (Exhaust gas-Engine)	Exhaust gas outlet cylinder head					
E.02-TI-001 [12]	+M1/26.8	+E1-26B12	Temperature control (Exhaust gas-Engine)	Exhaust gas outlet cylinder head					
E.02-TI-001 [13]	+M1/27.1	+E1-27B13	Temperature control (Exhaust gas-Engine)	Exhaust gas outlet cylinder head					
E.02-TI-001 [14]	+M1/27.2	+E1-27B14	Temperature control (Exhaust gas-Engine)	Exhaust gas outlet cylinder head					
E.02-TI-001 [15]	+M1/27.4	+E1-27B15	Temperature control (Exhaust gas-Engine)	Exhaust gas outlet cylinder head					
E.02-TI-001 [16]	+M1/27.5	+E1-27B16	Temperature control (Exhaust gas-Engine)	Exhaust gas outlet cylinder head					
E.02-TI-001 [17]	+M1/27.7	+E1-27B17	Temperature control (Exhaust gas-Engine)	Exhaust gas outlet cylinder head					
E.02-TI-001 [18]	+M1/27.8	+E1-27B18	Temperature control (Exhaust gas-Engine)	Exhaust gas outlet cylinder head					
E.02-TI-001 [19]	+M1/28.1	+E1-28B19	Temperature control (Exhaust gas-Engine)	Exhaust gas outlet cylinder head					
E.02-TI-001 [20]	+M1/28.2	+E1-28B20	Temperature control (Exhaust gas-Engine)	Exhaust gas outlet cylinder head					
E.08-PI-001	+M1/40.3	+E1-40B23	Pressure control (Air/Fuel-gas mixture-Engine)	Charge pressure (mixture pressure p2')					
E.08-TI-001	+M1/41.2	+E1-41B26	Temperature control (Air/Fuel-gas mixture-Engine)	Mixture temperature t2'					
E.08-M-001	+M1/53.6	+E1-53M6	Engine (Air/Fuel-gas mixture-Engine)	Throttle valve actuating drive					
E.08-YCI-101	+M1/54.0	+E1-54M7	Valve with position controller (Air/Fuel-gas mixture-Engine)	Electrical control valve - Exhaust-gas turbocharger bypass system					
G.00-A-001	+G1/4.2	+G1-462	Generator (Engine block-Generator)	Generator-coil temperature					
G.00-TI-040 [01]	+G1/5.1	+G1-5B1	Temperature control (Engine block-Generator)	Generator-coil temperature					
G.00-TI-040 [02]	+G1/5.2	+G1-5B2	Temperature control (Engine block-Generator)	Generator-coil temperature					

3

5

		Date	18.01.06	4 x JGS 320 GS-L.L	 Jenbacher gas engines	Designation of the components	SD-Nr. Project	8662
		Desig.	Senfter M.	Nelson Gardens LFG			Suffix	
		Print	24.04.12				Wiring diagram	J N795 + B / 4
Modific.	Date	Name	Check	Pieschnik A.	DIR: J:\EPLAN4\VP\ANL\BEN\WXXX\N7XX\JN795.P			

EPLAN 5

0	1	2	3	4	5	6	7	8	9
Abbreviation	Page	Elec. wiring diagram Number	Denomination	Comment					
6.00-TI-040 [03]	+61/5.3	+61-5B3	Temperature control (Engine block-Generator)	Generator-coil temperature					
6.00-TI-040 [04]	+61/5.4	+61-5B4	Temperature control (Engine block-Generator)	Generator-coil temperature					
6.00-TI-040 [05]	+61/5.5	+61-5B5	Temperature control (Engine block-Generator)	Generator-coil temperature					
6.00-TI-040 [06]	+61/5.6	+61-5B6	Temperature control (Engine block-Generator)	Generator-coil temperature					
6.00-TI-030 [01]	+61/5.7	+61-5B7	Temperature control (Engine block-Generator)	Generator-bearing temperature - DE (Drive End)					
6.00-TI-030 [02]	+61/5.8	+61-5B8	Temperature control (Engine block-Generator)	Generator-bearing temperature - NDE (Nondrive End)					
M.03-M-003	+M1/12.4	+E1-12M3	Engine (Lubricating oil-Module)	Engine oil pump - DC prelubrication + continued cooling					
M.03-PI-001	+M1/40.0	+E1-40B21	Pressure control (Lubricating oil-Module)	Engine oil pressure					
M.03-TI-001	+M1/41.3	+E1-41B27	Temperature control (Lubricating oil-Module)						
M.03-YCS-001	+M1/42.0	+E1-42M5	Valve Open/Closed (Lubricating oil-Module)	Solenoid valve - Automatic topping up of engine oil					
M.03-LI-001	+M1/42.3	+E1-42B30	Level sensor (Lubricating oil-Module)	Engine oil level in engine oil pan					
M.03-PDS-001	+M1/43.1	+E1-43B32	Differential-pressure switch (Lubricating oil-Module)	Engine oil filter					
M.04-M-002	+M1/10.1	+E1-10M1	Engine (Cooling water-Module)	Engine cooling water preheating					
M.04-TS-001 [01]	+M1/10.3	+E1-10E1	Temperature switch (Cooling water-Module)	Engine cooling water preheating					
M.04-PI-001	+M1/40.2	+E1-40B22	Pressure control (Cooling water-Module)	Engine cooling-water pressure					
M.04-TI-001	+M1/41.4	+E1-41B28	Temperature control (Cooling water-Module)	Engine cooling water temperature					
M.05-TI-001	+M1/41.6	+E1-41B29	Temperature control (Air-Module)	Intake air temperature					
M.06-TI-001	+M1/48.4	+E1-48B33	Temperature control (High temperature circuit-Module)	Return temperature (before engine)					
P.01-PS-101	+M1/44.0	+P1-44B1	Pressure switch (Fuel gas-System)	Gas pressure min. - Gas pressure control system 1					
P.01-US-101	+M1/51.1	+P1-51K1	Leak testing (Fuel gas-System)	Gas pressure control system 1					
P.07-PS-001	+A1/49.1	+P1-49B3	Pressure switch (Low temperature circuit-System)						
P.17-TI-010	+A1/47.7	+P1-47B2	Temperature control (Ventilation system-System)	Room temperature					

		Date	18.01.06	4 x JGS 320 GS-L.L	 Jenbacher gas engines	Designation of the components	SD-Nr. Project	8662
		Desig.	Senfter M.	Nelson Gardens LFG			Suffix	
		Print	24.04.12				Wiring diagram	J N795 + B / 5
Modific.	Date	Name	Check	Pieschnik A.	DIR: J:\EPLAN\4\VP\ANL\BEN\WXXX\N7XX\JN795.P			

Terminal	Jumpers	Terminal strip	Device / Function	Page
			Preheating pump	+M1/10.1
			=	+M1/10.1
			=	+M1/10.1
			=	+M1/10.2
			Preheating	+M1/10.3
			=	+M1/10.3
			=	+M1/10.3
			=	+M1/10.3
			Charging unit 1	+M1/10.5
			=	+M1/10.5
			=	+M1/10.5
			=	+M1/10.5
			cooling system	+M1/10.6
			=	+M1/10.6
			=	+M1/10.6
			=	+M1/10.6
			Anti condensation heater	+M1/10.9
			=	+M1/10.9
			=	+M1/10.9

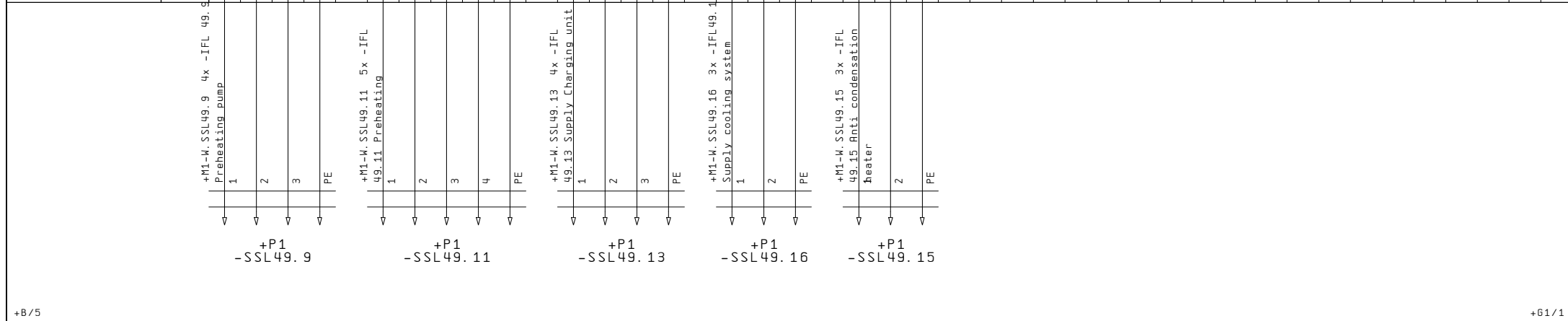

Generator +G1

Parameters for the operation
of GE Jenbacher Engines
acc. TI.Nr.: 1100-0110

Modifications of Design
reserved.

All Cables between the
Switchboards and the Engine
have to be in flexible mode.

Protection against electric shocks hazard
earthing, equipotential bonding, has to be
provided by the Customer at installation
according to local Standards !
At staes of delivery the engine
is prepared for the protection by
automatic disconnection of supply
in TN-Systems according to
HD 60364-4-41 / IEC 60364-4-41.

 The Numbers in the circles are in
Relation with the Numbers in the
Interface-List J N795

This Wiring Diagram is designed with
a CAE-System.
Modifications will be occupied by
GE Jenbacher

+E1/1

2

		Date	18.01.06	4 x JGS 320 GS-L.L	 Jenbacher gas engines	Generator +G1	SD-Nr. Project	8662
		Desig.	Senfter M.	Nelson Gardens LFG			Suffix	J xxxx
		Print	24.04.12				Wiring diagram	J N795 +G1 / 1
Modific.	Date	Name	Check	Pieschnik R.	DIR: J:\EPLAN4\P\ANL\GEN\WXXX\N7XX\JN795.P	KW 12 - 2012	EPLAN 5	

Diagram index

Page	Denomination	Modifications	Page	Denomination	Modifications
+G1/1	Generator +G1				
+G1/2	Diagram index				
+G1/3	Over view Terminal strips				
+G1/4	Generator				
+G1/5	Windings temperature Bearing temperature				
+G1/6	Generator				
+G1/7	Anti condensation heater				
+G1/8	Terminals Generator +G1				
+G1/9	Terminals Generator +G1				
+G1/10	Terminals Controller DECS 100				

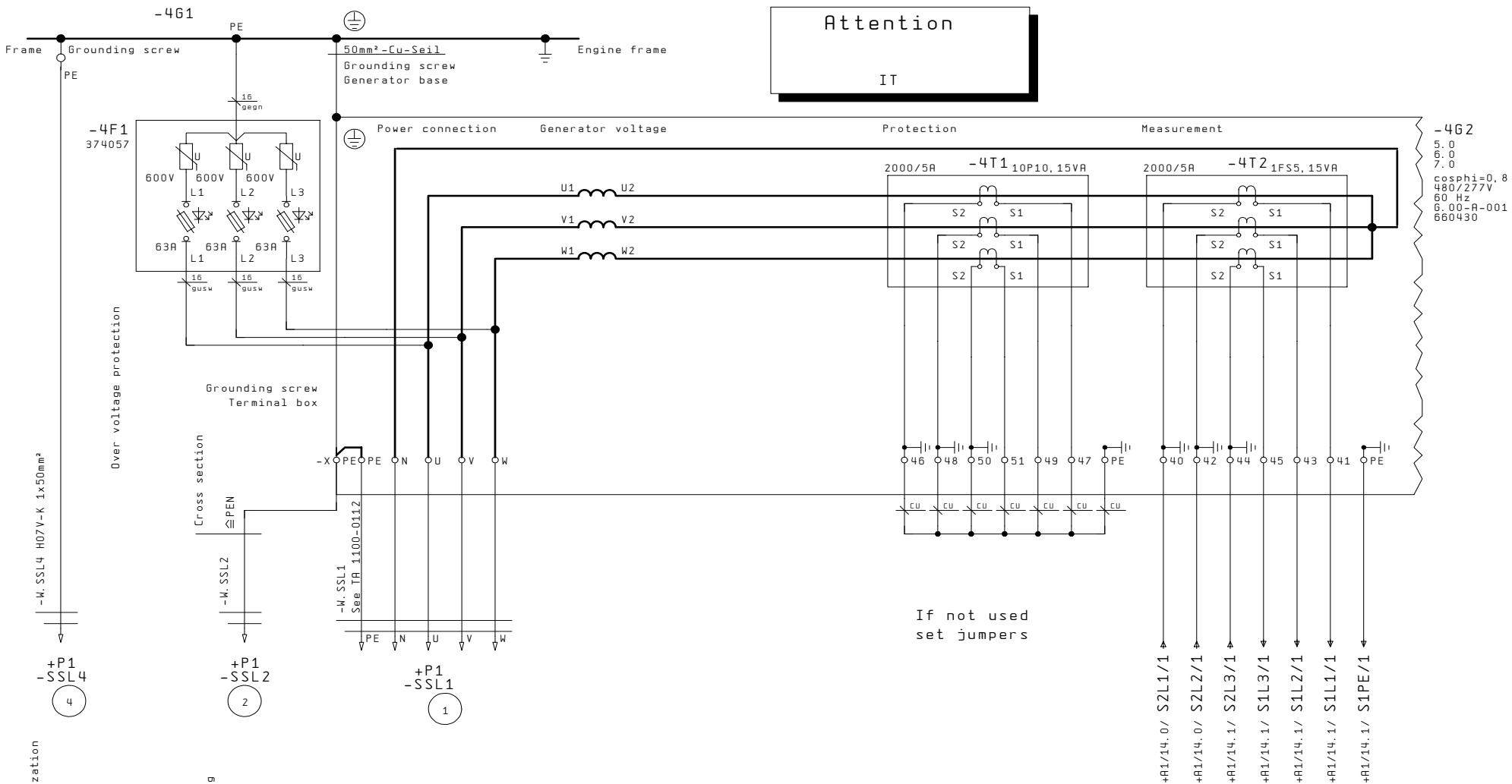

ONLY HIGH FLEXIBLE SINGLE CORE CABLE ARE PERMITTED
See TA 1100-0112

3		Date 18.01.06		4 x JGS 320 GS-L.L		Jenbacher gas engines Generator		SD-Nr. Project 8662	
		Desig. Senfter M.		Nelson Gardens LFG				Suffix J xxxx	
		Print 24.04.12		DIR: J:\EPLAN4\VP\ANL\BEN\WXXX\N7XX\JN795.P		KW 12 - 2012 EPLAN 5		Wiring diagram J N795 + G1 / 4	
Modific.	Date	Name	Check	Pieschnik A.					

Generator Terminal box

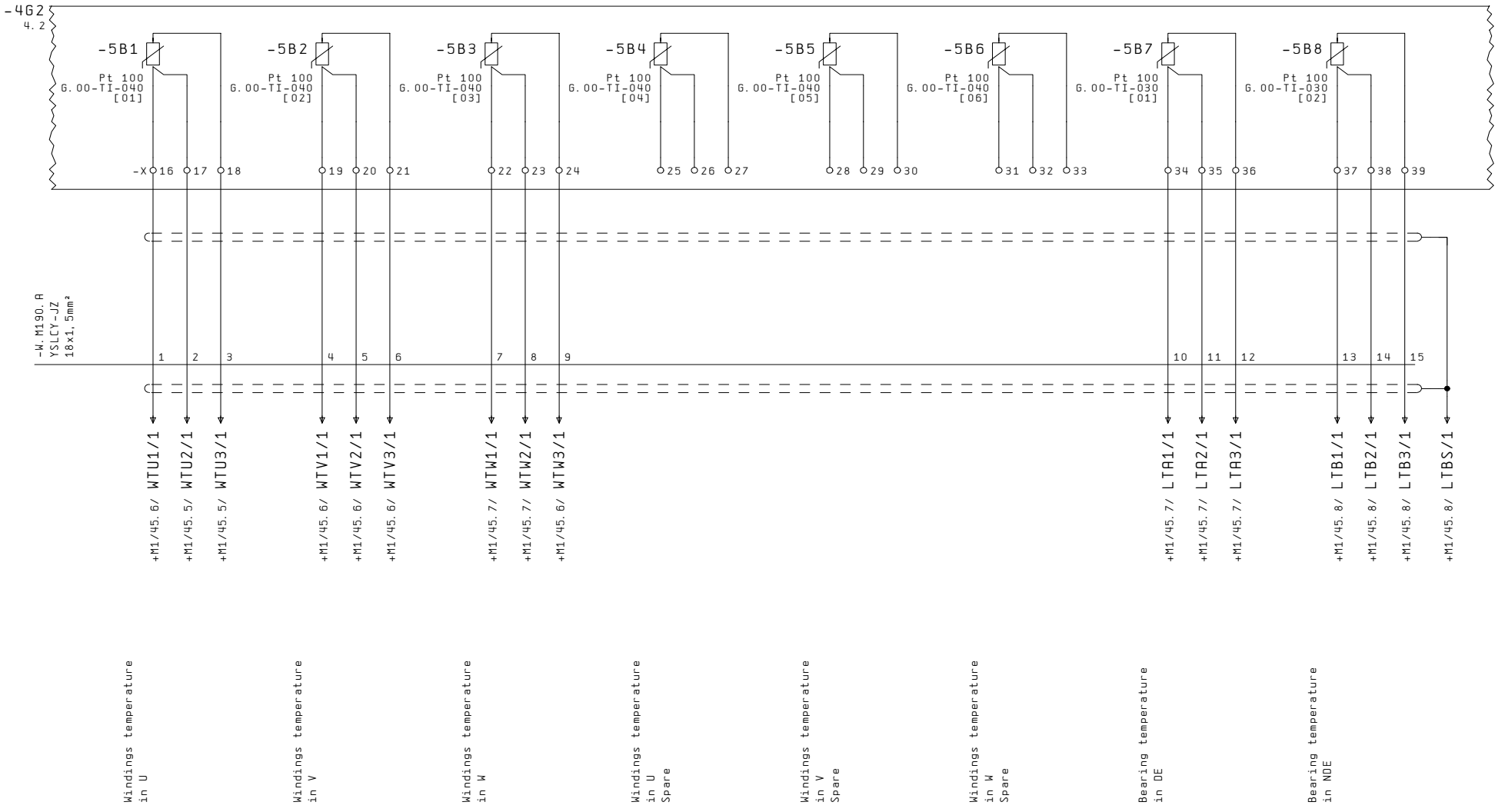

Modific.	Date	Name	Check	Pieschnik A.	DIR: J:\EPLAN4\VP\ANL\BEN\WXXX\N7XX\JN795.P	 Jenbacher gas engines	Windings temperature Bearing temperature	SD-Nr. Project	8662
								Suffix	J xxxx
								Wiring diagram	J N795 + G1 / 5

-462
4.2

DECS
Terminal box

BASLER DM110

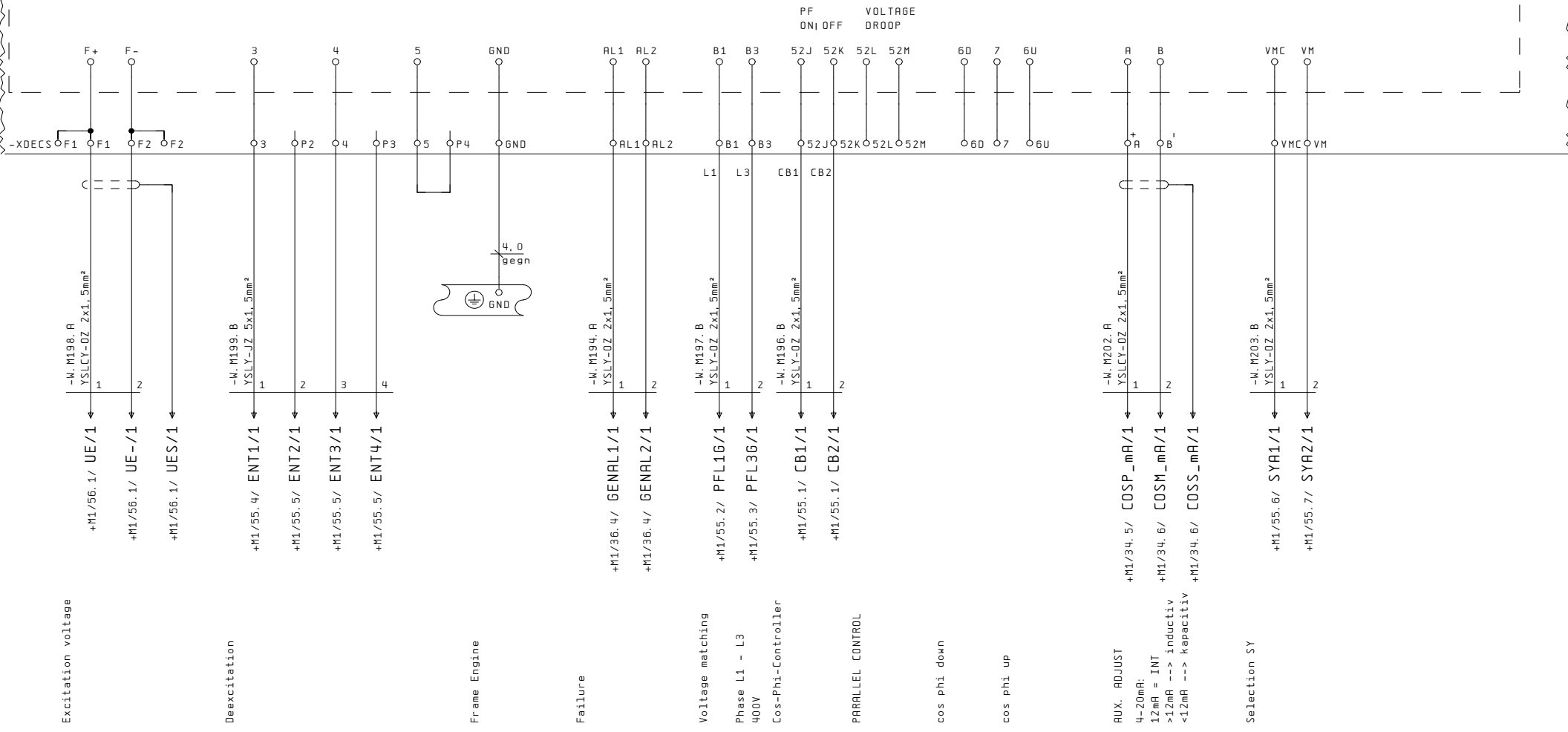
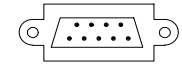

5

7

Date		18.01.06		4 x JGS 320 GS-L.L		Jenbacher gas engines	Generator		SD-Nr.	8662	
Desig.		Senfter M.		Nelson Gardens LFG			Suffix	J xxxx			
Print		24.04.12					Wiring diagram	J N795 + G1		/ 6	
Modific.	Date	Name	Check	Pieschnik A.		DIR: J:\EPLAN4\VP\ANL\BEN\WXXX\N7XX\JN795.P		KW 12 - 2012		EPLAN 5	

Generator Terminal box

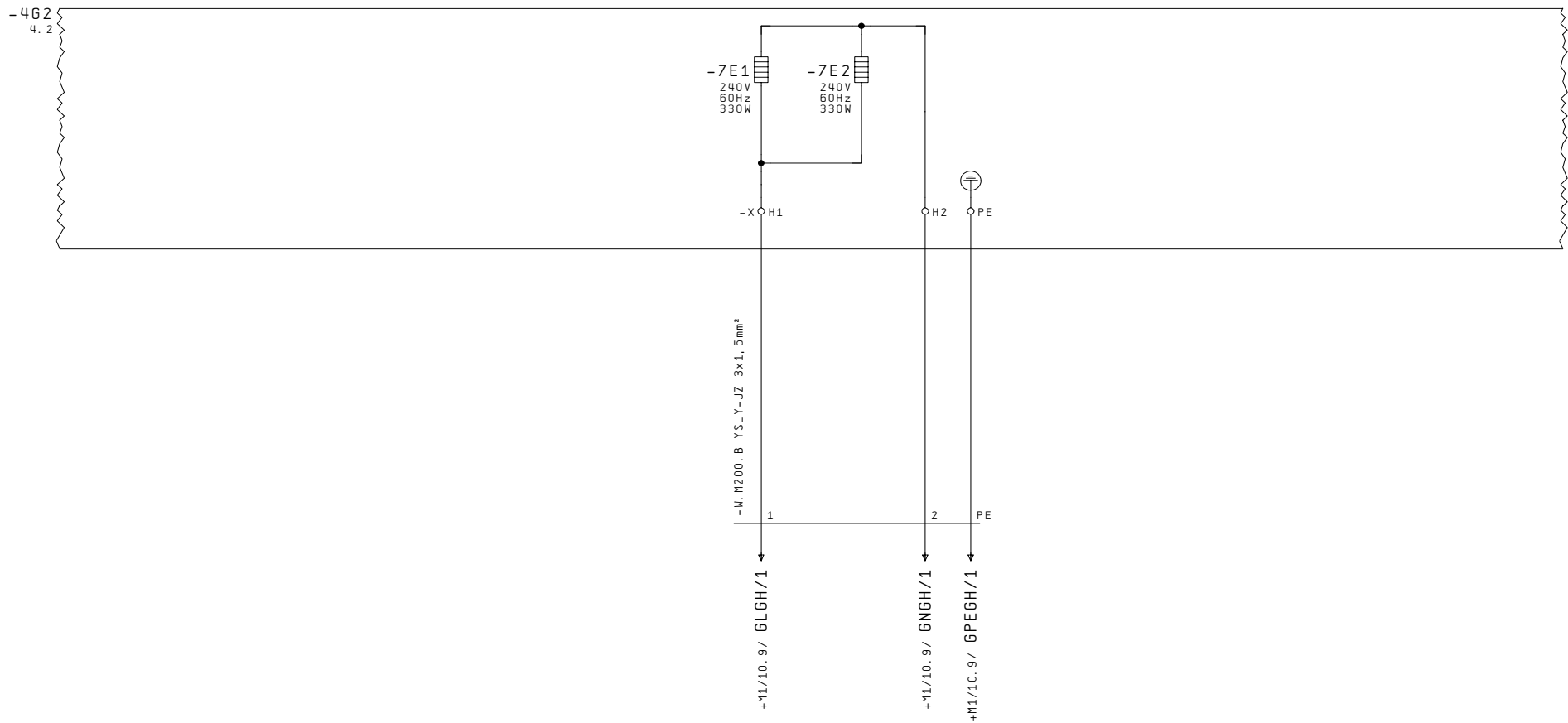

Anti condensation heater

		Date	18.01.06	4 x JGS 320 GS-L.L	 Jenbacher gas engines	Anti condensation heater	SD-Nr. Project	8662
		Desig.	Senfter M.	Nelson Gardens LFG		Suffix	J xxxx	
		Print	24.04.12			Wiring diagram	J N795 + G1 / 7	
Modific.	Date	Name	Check	Pieschnik A.	DIR: J:\EPLAN4\VP\ANL\GEN\WXXX\N7XX\JN795.P	KW 12 - 2012	EPLAN 5	

Terminal	Jumpers	Terminal strip	Device / Function	Page
○ PE	● — ●	+G1-M, SSL2 1x -IFL 2 Service grounding	-IFL 2 Service grounding	/4.2
○ PE		+G1-M, SSL1 5x See TF 1100-0112	-IFL 1 Power connection	/4.2
○ N		1	=	/4.2
○ U		2	=	/4.2
○ V		3	=	/4.3
○ W		4	=	/4.3
○ 16		+G1-M, M190, A YSLCY-JZ 18x1.5mm ² Windings temperature in U	Windings temperature in U	/5.1
○ 17		2	=	/5.1
○ 18		3	=	/5.1
○ 19		4	Windings temperature in V	/5.2
○ 20		5	=	/5.2
○ 21		6	=	/5.2
○ 22		7	Windings temperature in W	/5.3
○ 23		8	=	/5.3
○ 24		9	=	/5.3
○ 25			Windings temperature in U Spare	/5.4
○ 26			=	/5.4
○ 27			=	/5.4
○ 28			Windings temperature in V Spare	/5.5
○ 29			=	/5.5
○ 30			=	/5.5
○ 31			Windings temperature in W Spare	/5.6
○ 32			=	/5.6
○ 33			=	/5.6
○ 34			Bearing temperature in DE	/5.7
○ 35			=	/5.7
○ 36			=	/5.7

Date		18.01.06		4 x JGS 320 GS-L.L		 Jenbacher gas engines	Terminals Generator +G1		SD-Nr. Project 8662		
Design		Senfter M.		Nelson Gardens LFG					Suffix		
Print		24.04.12		DIR: J:\EPLAN4\VP\ANL\BEN\WXXX\N7XX\JN795.P			EPLAN 5		Wiring diagram J N795 +G1 / 8		
Modific.	Date	Name	Check	Pieschnik A.							

0	1	2	3	4	5	6	7	8	9																																																
Terminal strip	+G1-X																																																								
Jumpers																																																									
Terminal																																																									
	<div style="display: flex; justify-content: space-between;"> <div style="width: 30%;"> <p>+G1-M. M190. R YSLY-JZ 18x1.5mm² Windings Temperature in U</p> <p>14</p> <p>15</p> </div> <div style="width: 35%;"> <p>+R1-M. E4. R YSLY-JZ 7x2.5mm² Generator current</p> <p>1</p> <p>2</p> <p>3</p> <p>4</p> <p>5</p> <p>6</p> <p>PE</p> </div> <div style="width: 30%;"> <p>+G1-M. M200. B YSLY-JZ 3x1.5mm² Anti condensation heater</p> <p>1</p> <p>2</p> <p>PE</p> </div> </div>																																																								
	<table border="1"> <thead> <tr> <th>Device / Function</th> <th>Page</th> </tr> </thead> <tbody> <tr><td>Bearing temperature in NDE</td><td>/5.8</td></tr> <tr><td>=</td><td>/5.8</td></tr> <tr><td>=</td><td>/5.8</td></tr> <tr><td>Protection</td><td>/4.5</td></tr> <tr><td>=</td><td>/4.6</td></tr> <tr><td>=</td><td>/4.6</td></tr> <tr><td>=</td><td>/4.6</td></tr> <tr><td>=</td><td>/4.6</td></tr> <tr><td>=</td><td>/4.6</td></tr> <tr><td>=</td><td>/4.6</td></tr> <tr><td>=</td><td>/4.7</td></tr> <tr><td>Measurement</td><td>/4.7</td></tr> <tr><td>=</td><td>/4.7</td></tr> <tr><td>=</td><td>/4.7</td></tr> <tr><td>=</td><td>/4.7</td></tr> <tr><td>=</td><td>/4.7</td></tr> <tr><td>=</td><td>/4.8</td></tr> <tr><td>=</td><td>/4.8</td></tr> <tr><td>=</td><td>/4.8</td></tr> <tr><td>=</td><td>/4.8</td></tr> <tr><td>Anti condensation heater</td><td>/7.4</td></tr> <tr><td>=</td><td>/7.5</td></tr> <tr><td>=</td><td>/7.5</td></tr> </tbody> </table>									Device / Function	Page	Bearing temperature in NDE	/5.8	=	/5.8	=	/5.8	Protection	/4.5	=	/4.6	=	/4.6	=	/4.6	=	/4.6	=	/4.6	=	/4.6	=	/4.7	Measurement	/4.7	=	/4.7	=	/4.7	=	/4.7	=	/4.7	=	/4.8	=	/4.8	=	/4.8	=	/4.8	Anti condensation heater	/7.4	=	/7.5	=	/7.5
Device / Function	Page																																																								
Bearing temperature in NDE	/5.8																																																								
=	/5.8																																																								
=	/5.8																																																								
Protection	/4.5																																																								
=	/4.6																																																								
=	/4.6																																																								
=	/4.6																																																								
=	/4.6																																																								
=	/4.6																																																								
=	/4.6																																																								
=	/4.7																																																								
Measurement	/4.7																																																								
=	/4.7																																																								
=	/4.7																																																								
=	/4.7																																																								
=	/4.7																																																								
=	/4.8																																																								
=	/4.8																																																								
=	/4.8																																																								
=	/4.8																																																								
Anti condensation heater	/7.4																																																								
=	/7.5																																																								
=	/7.5																																																								

Terminal	Jumpers	Terminal strip	Page
+M1-XM1 070	+G1-M. M199. B YSLY-JZ 5x1.5mm ² Deexcitation 1	0-3	/6.1
072	3	=	/6.2
+M1-XM1 0685	+G1-M. M202. A YSLCY-OZ 2x1.5mm ² AUX. ADJUST 1	0-5	/6.2
0687	2	cos phi down	/6.6
+M1-XM1 0791	+G1-M. M197. B YSLY-OZ 2x1.5mm ² Failure 1	0-A	/6.7
0793	2	AUX. ADJUST	/6.7
0	+G1-M. M198. A YSLCY-OZ 2x1.5mm ² Excitation voltage 1	0-60	/6.6
2	2	=	/6.6
+M1-XM1 071	+G1-M. M199. B YSLY-JZ 5x1.5mm ² Deexcitation 2	0-F1	/6.2
073	4	=	/6.2
059	+G1-M. M203. B YSLY-OZ 2x1.5mm ² Selection SY 2	0-F2	/6.3
056	+G1-M. M196. B YSLY-OZ 2x1.5mm ² Cos-Phi-Controller 1	0-6ND	/6.3
057	2	Selection SY	/6.8
+M1-XM1 0176	+G1-M. M194. A YSLY-OZ 2x1.5mm ² Failure 1	0-VH	/6.5
0177	2	Cos-Phi-Controller	/6.5
+M1-XM1 058	+G1-M. M203. B YSLY-OZ 2x1.5mm ² Selection SY 1	0-5ZJ	/6.5
		=	/6.5
		PARALLEL CONTROL	/6.5
		=	/6.5
		Failure	/6.4
		=	/6.4
		Selection SY	/6.8

Date		18.01.06		4 x JGS 320 GS-L.L		 Jenbacher gas engines	Terminals Controller DECS 100	SD-Nr. Project		8662	
Desig.		Senfter M.		Nelson Gardens LFG				Suffix			
Print		24.04.12		DIR: J:\EPLAN4\VP\ANL\BEN\WXXX\N7XX\JN795.P				Wiring diagram		J N795 + G1 / 10	
Modific.	Date	Name	Check	Pieschnik A.		EPLAN 5					

Module interface +M1

Parameters for the operation
of GE Jenbacher Engines
acc. TI.Nr.: 1100-0110

Modifications of Design
reserved.

All Cables between the
Switchboards and the Engine
have to be in flexible mode.

Protection against electric shocks hazard
earthing, equipotential bonding, has to be
provided by the Customer at installation
according to local Standards !
At staes of delivery the engine
is prepared for the protection by
automatic disconnection of supply
in TN-Systems according to
HD 60364-4-41 / IEC 60364-4-41.

 The Numbers in the circles are in
Relation with the Numbers in the
Interface-List J N795

This Wiring Diagram is designed with
a CAE-System.
Modifications will be occupied by
GE Jenbacher

+G1/10

2

		Date	18.01.06	4 x JGS 320 GS-L.L	 Jenbacher gas engines	Module interface +M1	SD-Nr. Project	8662
		Desig.	Senfter M.	Nelson Gardens LFG			Suffix	J xxxx
		Print	24.04.12					Wiring diagram
Modific.	Date	Name	Check	Pieschnik R.	DIR: J:\EPLAN4\P\ANL\GEN\WXXX\N7XX\JN795.P	KW 12 - 2012	EPLAN 5	

Diagram index

Page	Denomination	Modifications	Page	Denomination	Modifications
+M1/1	Module interface +M1		+M1/14	Charging unit 1	
+M1/2	Diagram index		+M1/15	Resistors	
+M1/2.1	Diagram index		+M1/16	Over view modules	
+M1/2.2	Diagram index		+M1/17	Slot address Over view	
+M1/3	Technical information		+M1/18	Slot address Over view	
+M1/4	type plate		+M1/19	Slot address Over view	
+M1/5	Wiring colours in panel		+M1/20	Slot address Over view	
+M1/6	Over view Terminal strips		+M1/21	Slot address Over view	
+M1/7	Module interface cubicle		+M1/22	Slot address Over view	
+M1/8	Earthing/Grounding		+M1/23	Slot address Over view	
+M1/9	Distribution 24VDC		+M1/24	BUS-RECEIVER	
+M1/10	480V - Junction Box		+M1/25	Analog Inputs	
+M1/11	Starting device		+M1/26	Analog Inputs	
+M1/12	Prelubrication oil pump		+M1/27	Analog Inputs	
+M1/13	Control battery		+M1/28	Analog Inputs	

Diagram index

Page	Denomination	Modifications	Page	Denomination	Modifications
+M1/29	Analog Inputs		+M1/44	Monitoring: Gas pressure	
+M1/30	Analog Inputs		+M1/45	Signals <-> Generator	
+M1/31	Analog Inputs		+M1/46	Air-gas mixer	
+M1/32	Analog Inputs		+M1/47	Control Gas engine	
+M1/33	Analog Inputs		+M1/48	Temperature sensor	
+M1/34	Analog Outputs		+M1/49	Emergency stop	
+M1/35	Digital Inputs		+M1/50	Emergency stop Relay	
+M1/36	Digital Inputs		+M1/51	1 Gas train	
+M1/37	Digital Outputs		+M1/52	Gas valves	
+M1/38	Digital Outputs		+M1/53	Butterfly flap	
+M1/39	Control: Step motor		+M1/54	Turbo bypass valves	
+M1/40	Sensors Gas engine		+M1/55	Signals Generator <--> +M	
+M1/41	Sensors Gas engine		+M1/56	Signals Generator <--> +M	
+M1/42	Monitoring: Gas engine		+M1/57	CAN Bus	
+M1/43	Monitoring: Gas engine		+M1/58	Ignition system MIC950	

2

2. 2



		Date	18.01.06	4 x JGS 320 GS-L.L	 Jenbacher gas engines	Diagram index	SD-Nr.	8662
		Desig.	Senfter M.	Nelson Gardens LFG			Suffix	J xxxx
		Print	24.04.12				Wiring diagram	J N795 + M1 / 2.1
Modific.	Date	Name	Check	Pieschnik A.	DIR: J:\EPLAN4\VP\ANL\BEN\WXXX\N7XX\JN795.P	KW 12 - 2012	EPLAN 5	

Diagram index

Page	Denomination	Modifications	Page	Denomination	Modifications
+M1/59	Ignition coils				
+M1/60	Spare				
+M1/61	Terminals general +M1				
+M1/62	Terminals general +M1				
+M1/63	Terminals External Voltage +M1				
+M1/64	Terminals Auxiliaries +M1				
+M1/65	Terminals Base - 0VDC				
+M1/66	Terminals Base - 0VDC				
+M1/67	Terminals Base +24VDC				
+M1/68	Terminals Base +24VDC				
+M1/69	Terminals Shielded cable +M1				
+M1/70	Terminals Shielded cable +M1				
+M1/71	Terminals Shielded cable +M1				

2.1

3

		Date	18.01.06	4 x JGS 320 GS-L.L		 Jenbacher gas engines	Diagram index		SD-Nr.	8662	
		Desig.	Senfter M.	Nelson Gardens LFG			Suffix	J xxxx			
		Print	24.04.12				Wiring diagram	J N795 +M1		/	2.2
Modific.	Date	Name	Check	Pieschnik R.	DIR: J:\EPLAN4\VP\ANL\BEN\WXXX\N7XX\JN795.P	KW 12 - 2012	EPLAN 5				

Insulation	Ue= 480V, Ui= 480V		
Net form:	TN-S		
Protection:	IP54		
Auxiliary power circuits	Vaux = 24VDC		
ambient temperature:	+5°C - +47°C	up positioned	<2000m
Relative humidity:	70%	Degree of fouling:	3
EMC Immunity:	Environment A	EMC Emission:	Environment B
Static frequency oscillation width:	+4 /- 6%	Static voltage difference:	+/- 10%
Dynamic frequency difference:	+18 / -25%	Frequency control settling time:	10sec
Dynamic voltage difference:	+35 / -25%	Voltage control settling time:	10sec
Weight:	apr. 250 kg		

2.2

4

		Date	18.01.06	4 x JGS 320 GS-L.L	 Jenbacher gas engines	Technical information	SD-Nr. Project	8662
		Desig.	Senfter M.	Nelson Gardens LFG			Suffix	J xxxx
		Print	24.04.12				Wiring diagram	J N795 + M1 / 3
Modific.	Date	Name	Check	Pieschnik A.	DIR: J:\EPLAN4\P\ANL\BEN\WXXX\N7XX\JN795.P	KW 12 - 2012	EPLAN 5	

 **Jenbacher**
gas engines

GE Jenbacher GmbH & Co. OG
Rchenseestraße 1-3
A-6200Jenbach (Austria)



Project	Job	8662	...
Wiring diagram		J N795 + M1	
Serial No.		1058640	
Year of manufacture		2012	
Standard		IEC 60439-1	

 **Jenbacher**
gas engines

GE Jenbacher GmbH & Co. OG
Rchenseestraße 1-3
A-6200Jenbach (Austria)



Project	Job	8662	...
Wiring diagram		J N795 + M2	
Serial No.		1058632	
Year of manufacture		2012	
Standard		IEC 60439-1	

 **Jenbacher**
gas engines

GE Jenbacher GmbH & Co. OG
Rchenseestraße 1-3
A-6200Jenbach (Austria)



Project	Job	8662	...
Wiring diagram		J N795 + M3	
Serial No.		1058629	
Year of manufacture		2012	
Standard		IEC 60439-1	

 **Jenbacher**
gas engines

GE Jenbacher GmbH & Co. OG
Rchenseestraße 1-3
A-6200Jenbach (Austria)



Project	Job	8662	...
Wiring diagram		J N795 + M4	
Serial No.		1058619	
Year of manufacture		2012	
Standard		IEC 60439-1	

		Date	18.01.06	4 x JGS 320 GS-L.L	 Jenbacher gas engines	type plate	SD-Nr. Project	8662
		Desig.	Senfter M.	Nelson Gardens LFG			Suffix	J xxxx
		Print	24.04.12				Wiring diagram	J N795 + M1 / 4
Modific.	Date	Name	Check	Pieschnik A.	DIR: J:\EPLAN4\P\ANL\AGEN\WXXX\N7XX\JN795.P	KW 12 - 2012	EPLAN 5	

Wiring colours in panel

AC :

Outside wire before (or) orange
 Auxiliaries-supply
 disconnecting device : [L1 / L2 / L3]



Outside wire after (sw) black
 Auxiliaries-supply
 disconnecting device : [L1 / L2 / L3]

External Voltage : (or) orange
 (U/I - Measurement)

Protective wire [PE] : (gegn) green/yellow

N-Conductor [N] : (hbl) light blue

Function ground : (tr) transparent

24V AC : (gr) (grey)

Standard Type: H05V-K (≤ 1,0mm²)
 H07V-K (≥ 1,5mm²)

Wiring colours in panel:

DC :

Plus : (rt) red

Minus : (br) brown

Control : (ws) white

Thermo compensation cable (gn) + green
 (ws) - white

External Voltage : (or) orange
 (Voltage free contacts)

Standard Type: H05V-K (≤ 1,0mm²)
 H07V-K (≥ 1,5mm²)

		Date	18.01.06	4 x JGS 320 GS-L.L	 Jenbacher gas engines	Wiring colours in panel	SD-Nr. Project	8662
		Desig.	Senfter M.	Nelson Gardens LFG			Suffix	J xxxx
		Print	24.04.12				Wiring diagram	J N795 + M1 / 5
Modific.	Date	Name	Check	Pieschnik A.	DIR: J:\EPLAN4\VP\ANL\BEN\WXXX\N7XX\JN795.P	KW 12 - 2012	EPLAN 5	

Over view: Terminal strips

Module interface

- X: -X=Terminals
 general +M1

- XH: -XH=Terminals
 Auxiliaries +M1

- XS: -XS=Terminals
 Shielded cable +M1

- XP: -XP=Terminals
 Base +24VDC

- XM: -XM=Terminals
 Base - 0VDC

- XE: -XE=Terminals
 External Voltage +M1

- XHK: -XHK=Terminals
 Supply 480V +M1

		Date	18.01.06	4 x JGS 320 GS-L.L	 Jenbacher gas engines	Over view Terminal strips	SD-Nr. Project	8662
		Desig.	Senfter M.	Nelson Gardens LFG			Suffix	J xxxx
		Print	24.04.12				Wiring diagram	J N795 + M1
Modific.	Date	Name	Check	Pieschnik R.	DIR: J:\EPLAN4\P\ANL\BEN\WXXX\N7XX\JN795.P	KW 12 - 2012	EPLAN 5	

left

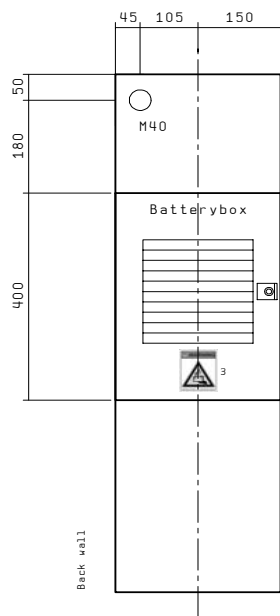

right

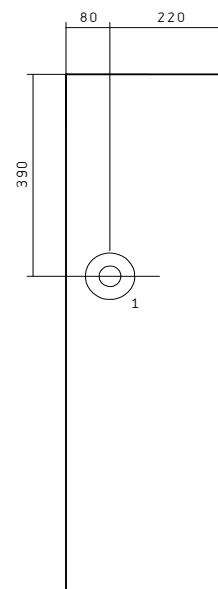

Protection internal:
IP 2x / IPxxB

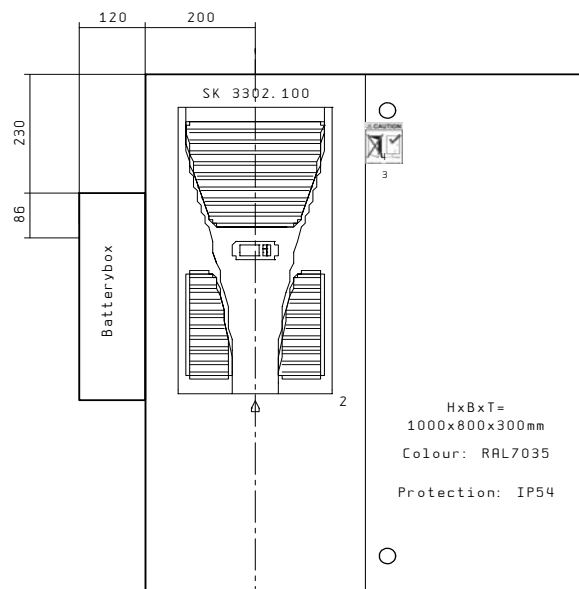

Terminal strip

-X, -XH, -XS, XE



Cable entry at the bottom

Emergency stop

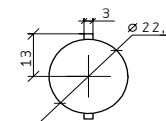

cooling system

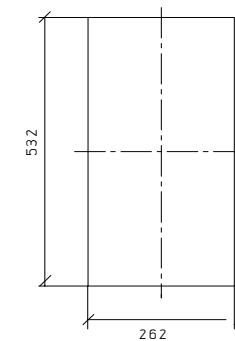

- 1 - 49S1 Emergency stop
- 2 - 10V1 cooling device
- 3 ... caution label

		Date	18.01.06	4 x JGS 320 GS-L.L	 Jenbacher gas engines	Module interface cubicle	SD-Nr.	8662
		Desig.	Senfter M.	Nelson Gardens LFG			Suffix	J xxxx
		Print	24.04.12				Wiring diagram	J N795 + M1 / 7
Modific.	Date	Name	Check	Pieschnik A.	DIR: J:\EPLAN4\VP\ANLAGEN\WXXX\N7XX\JN795.P	KW 12 - 2012	EPLAN 5	

1000x800x300

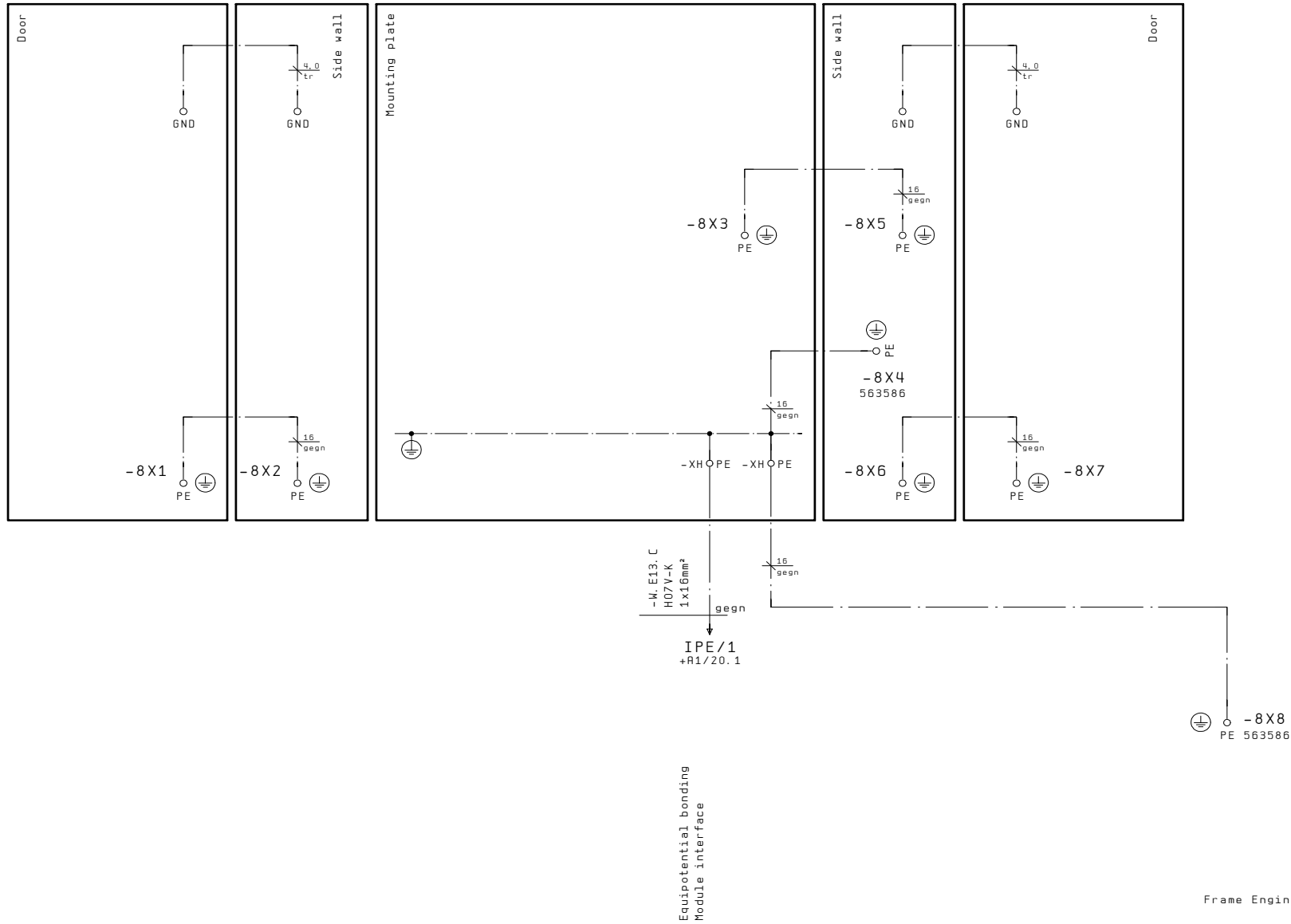

		Date	18.01.06	4 x JGS 320 GS-L.L	 Jenbacher gas engines	Earthing/Grounding	SD-Nr. Project	8662
		Desig.	Senfter M.	Nelson Gardens LFG			Suffix	J xxxx
		Print	24.04.12				Wiring diagram	J N795 + M1 / 8
Modific.	Date	Name	Check	Pieschnik A.	DIR: J:\EPLAN4\VP\ANL\BEN\WXXX\N7XX\JN795.P	KW 12 - 2012	EPLAN 5	

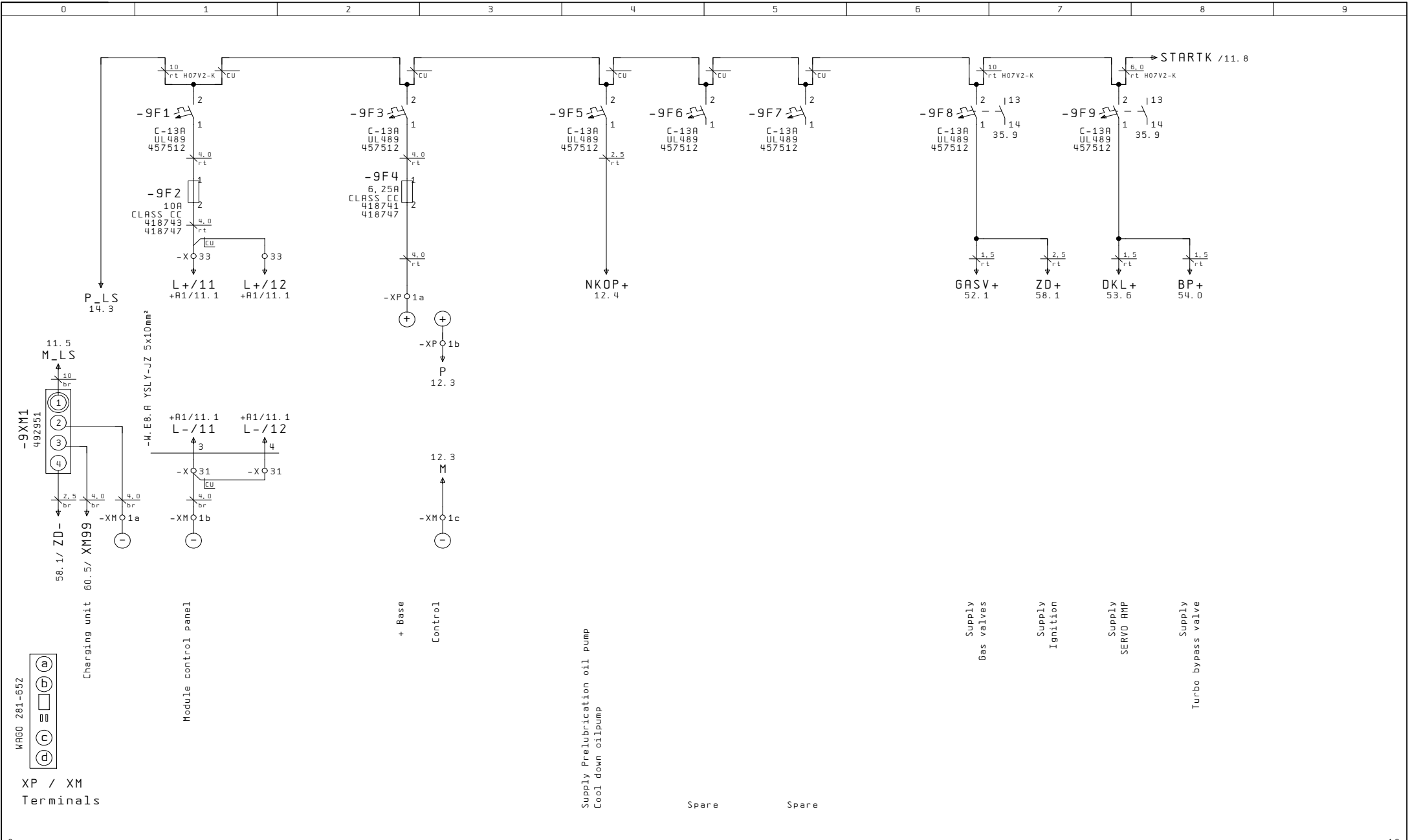

8		10				
Date	18.01.06	4 x JGS 320 GS-L.L	Jenbacher gas engines	Distribution 24VDC	SD-Nr. Project	8662
Desig.	Senfter M.	Nelson Gardens LFG			Suffix	J xxxx
Print	24.04.12	DIR: J:\EPLAN4\VP\ANL\BEN\WXXX\N7XX\JN795.P			KW 12 - 2012	EPLAN 5

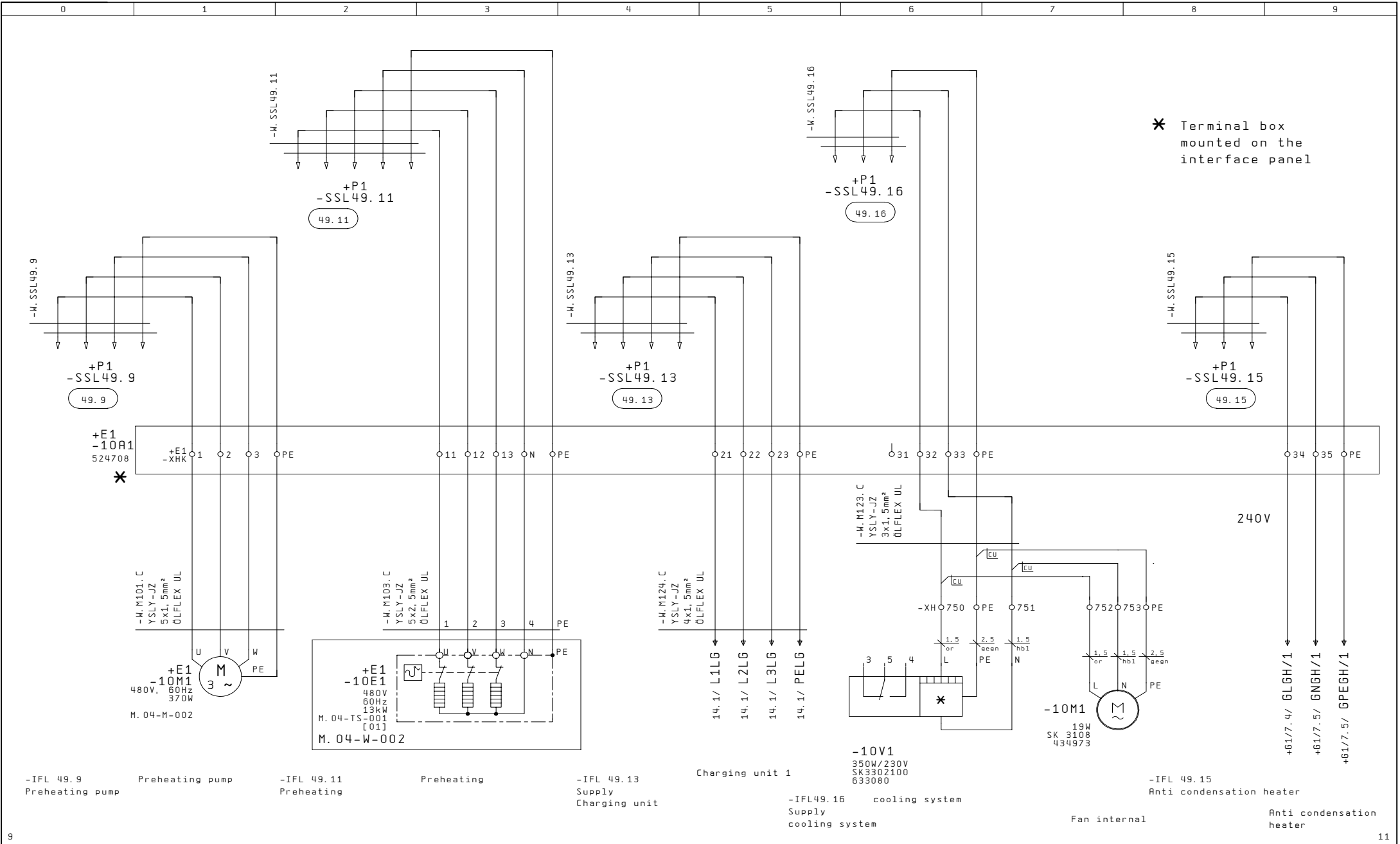

* Terminal box mounted on the interface panel

9		Date	18.01.06	4 x JGS 320 GS-L.L	 Jenbacher gas engines	480V - Junction Box	SD-Nr. Project	8662
		Desig.	Senfter M.	Nelson Gardens LFG			Suffix	J xxxx
		Print	24.04.12				Wiring diagram	J N795 + M1 / 10
Modific.	Date	Name	Check	Pieschnik A.	DIR: J:\EPLAN4\VP\ANL\BEN\WXXX\N7XX\N795.P	KW 12 - 2012	EPLAN 5	

→ STARTK /9. 8

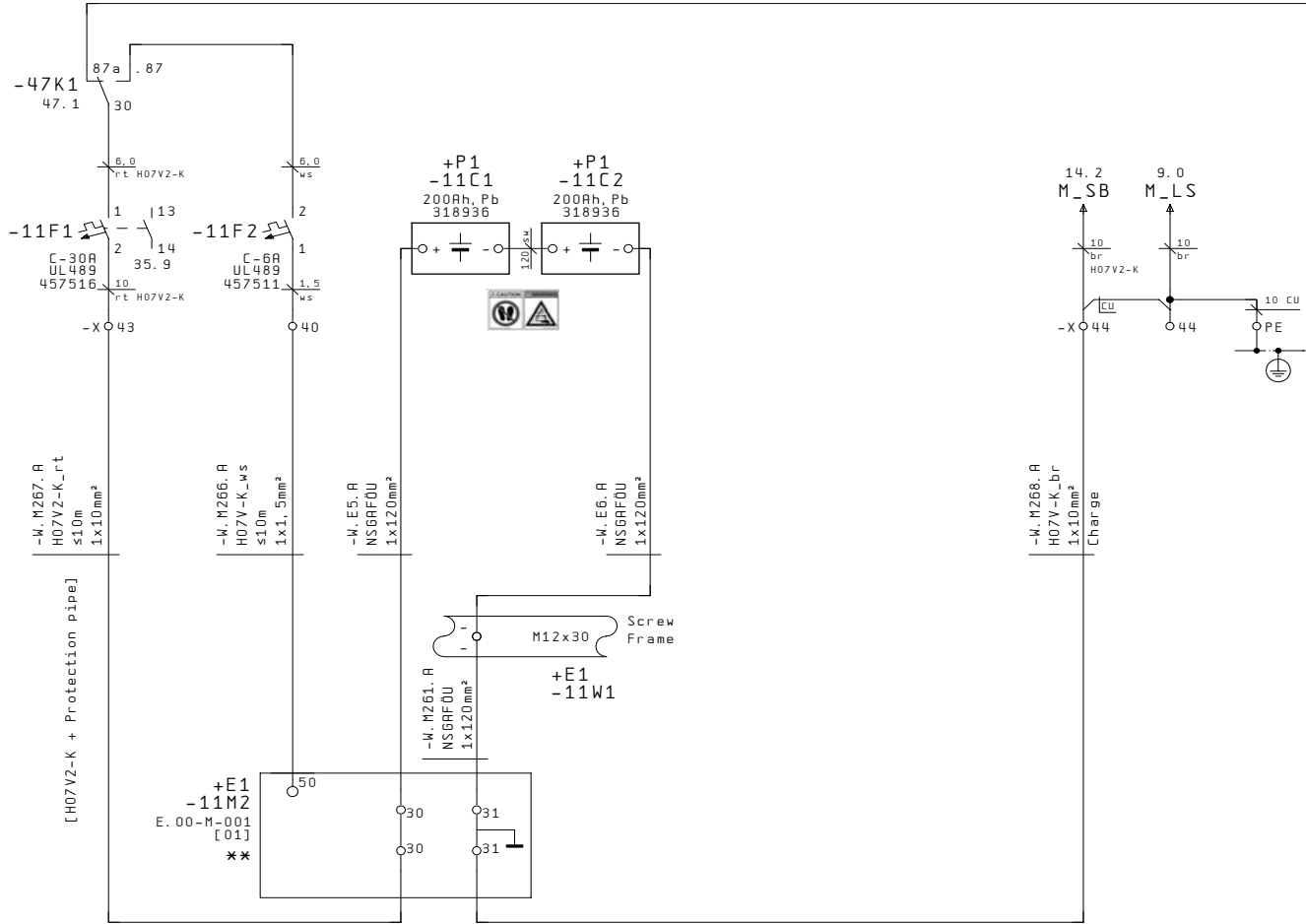

IP2x / IPxB
 24VDC Anschlüsse mit TL: 118602
 **: 30/31 Protection Terminal Part 123738

		Date	18.01.06	4 x JGS 320 GS-L.L		 Jenbacher gas engines	Starting device		SD-Nr.	8662
		Desig.	Senfter M.	Nelson Gardens LFG			Suffix	J xxxx		
		Print	24.04.12				Wiring diagram	J N795 + M1 / 11		
Modific.	Date	Name	Check	Pieschnik A.	DIR: J:\EPLAN4\VP\ANL\BEN\WXXX\N7XX\JN795.P	KW 12 - 2012	EPLAN 5			

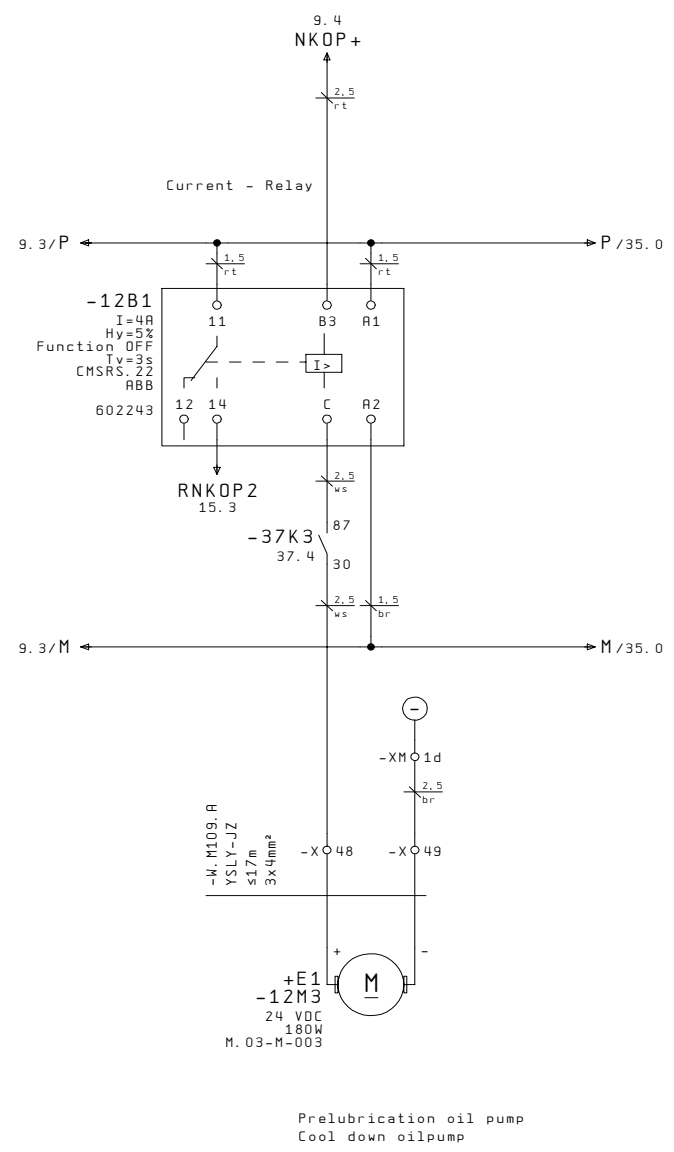

		Date	18.01.06	4 x JGS 320 GS-L.L	 Jenbacher gas engines	Prelubrication oil pump	SD-Nr.	8662
		Desig.	Senfter M.	Nelson Gardens LFG			Suffix	J xxxx
		Print	24.04.12				Wiring diagram	J N795 + M1 / 12
Modific.	Date	Name	Check	Pieschnik A.	DIR: J:\EPLAN4\P\ANLAGEN\XXXX\N7XX\JN795.P	KW 12 - 2012	EPLAN 5	

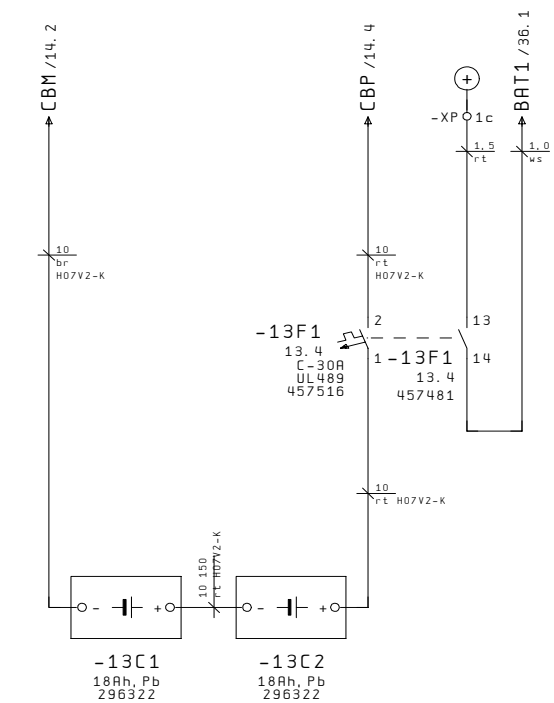

Control battery

Voltage sensor

		Date	18.01.06	4 x JGS 320 GS-L.L	 Jenbacher gas engines	Control battery	SD-Nr. Project	8662
		Desig.	Senfter M.	Nelson Gardens LFG			Suffix	J xxxx
		Print	24.04.12				Wiring diagram	J N795 + M1 / 13
Modific.	Date	Name	Check	Pieschnik A.	DIR: J:\EPLAN4\VP\ANL\BEN\WXXX\N7XX\JN795.P	KW 12 - 2012	EPLAN 5	

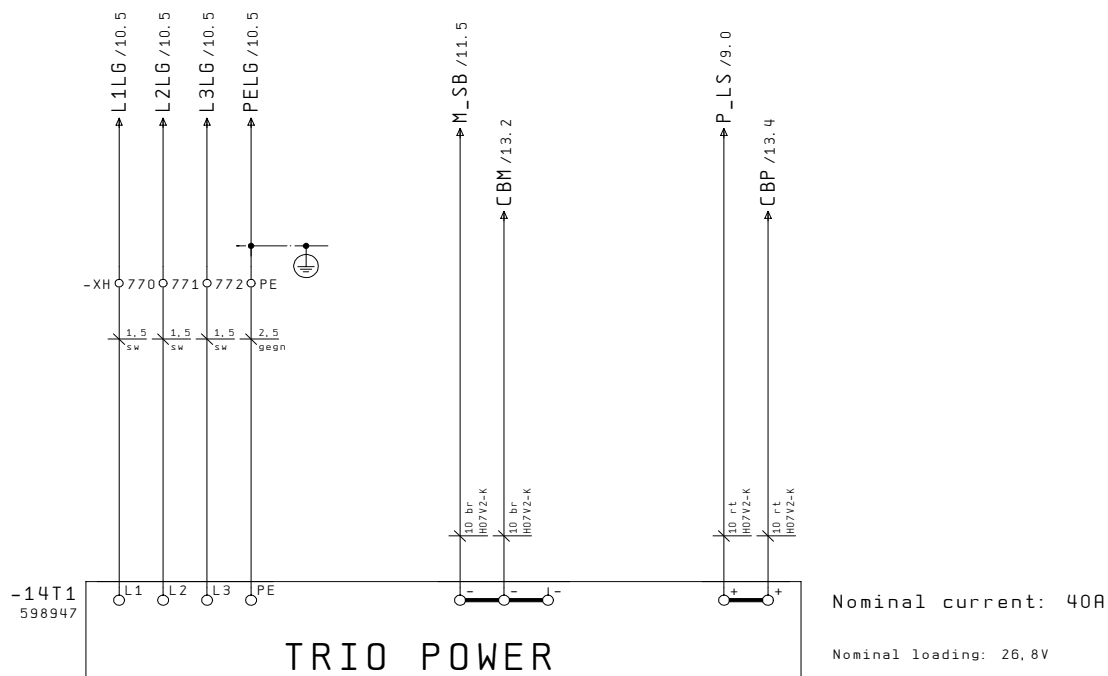

Supply
Charging unit

Charging unit
- Base

Charging unit
+ 24VDC

TRIO POWER

		Date	18.01.06	4 x JGS 320 GS-L.L	 Jenbacher gas engines	Charging unit 1	SD-Nr. Project	8662
		Desig.	Senfter M.	Nelson Gardens LFG			Suffix	J xxxx
		Print	24.04.12				Wiring diagram	J N795 + M1 / 14
Modific.	Date	Name	Check	Pieschnik A.	DIR: J:\EPLAN4\VP\ANL\GEN\WXXX\N7XX\JN795.P	KW 12 - 2012	EPLAN 5	

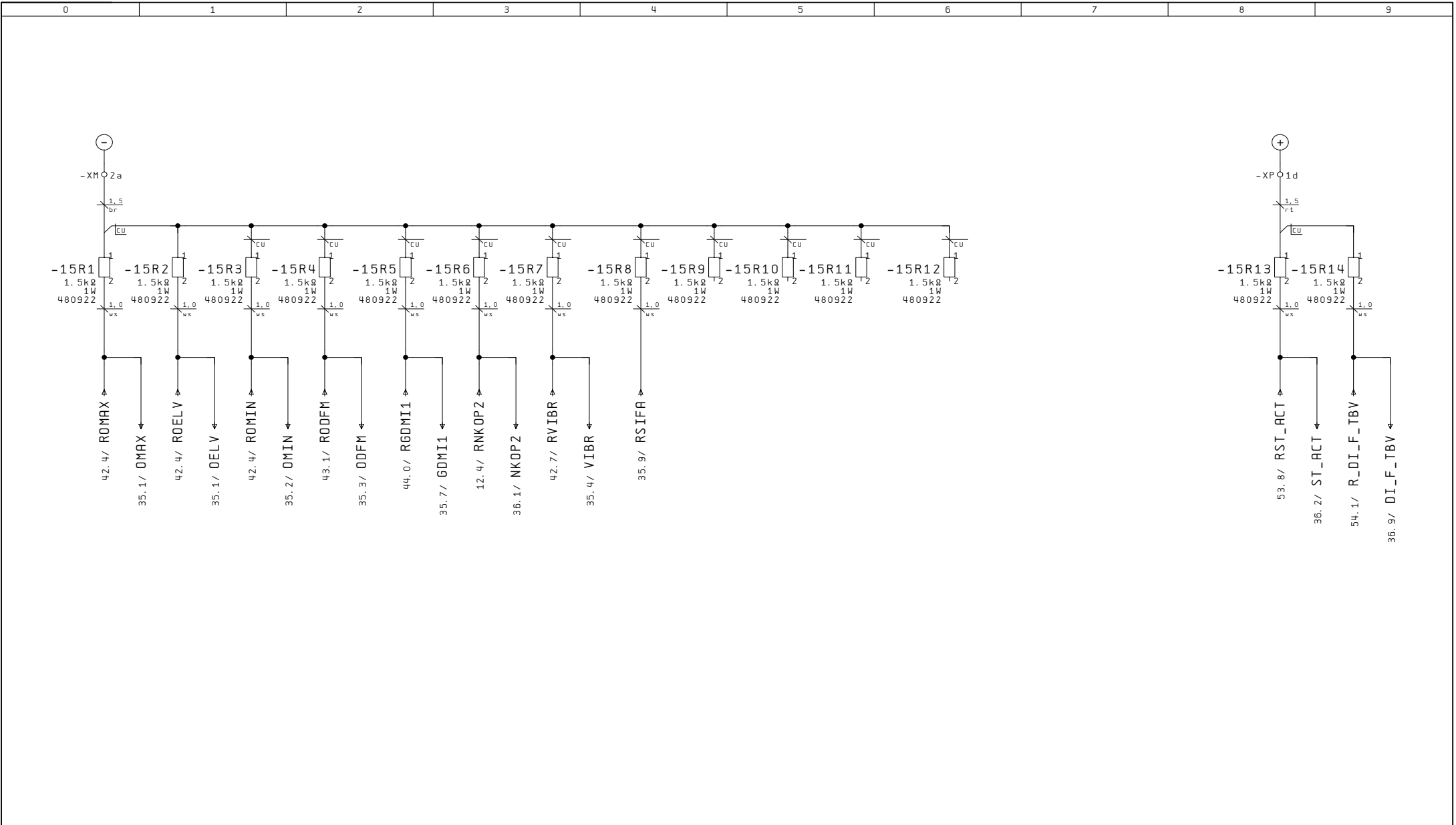

Resistor - Digital Input

Spare

Resistor - Digital Input

		Date	18.01.06	4 x JGS 320 GS-L.L		 Jenbacher gas engines	Resistors	SD-Nr.	8662	
		Desig.	Senfter M.	Nelson Gardens LFG				Suffix	J xxxx	
		Print	24.04.12					Wiring diagram	J N795 + M1 / 15	
Modific.	Date	Name	Check	Pieschnik A.	DIR: J:\EPLAN4\VP\ANL\BEN\WXXX\N7XX\JN795.P	KW 12 - 2012	EPLAN 5			

60 hex = 96 dez

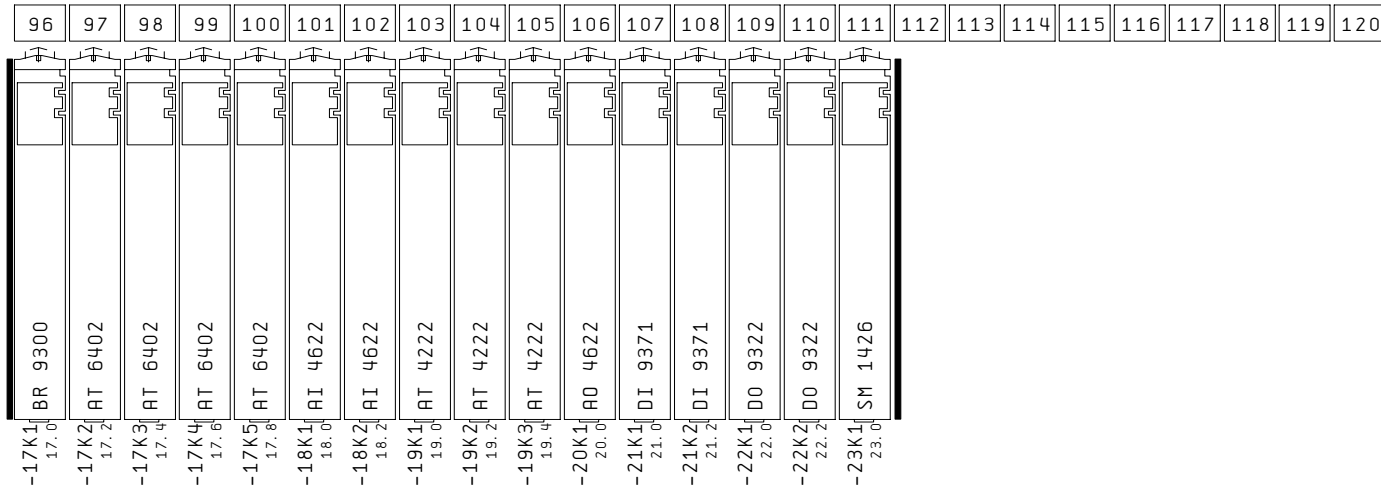

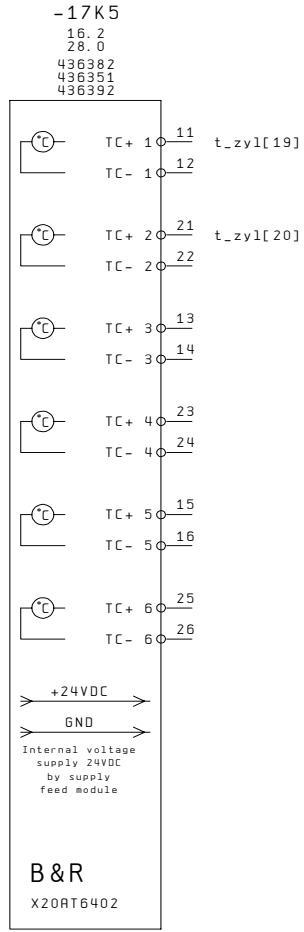
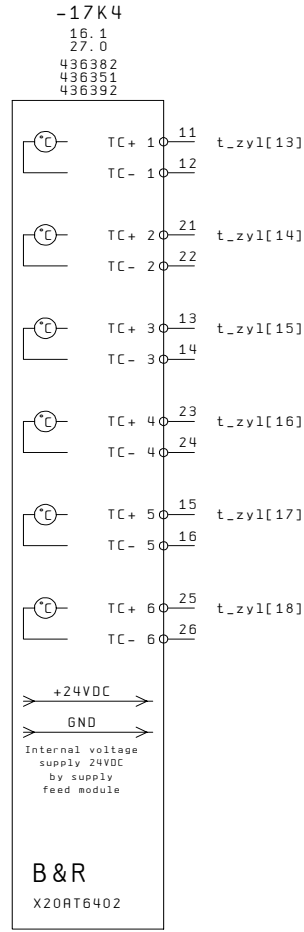
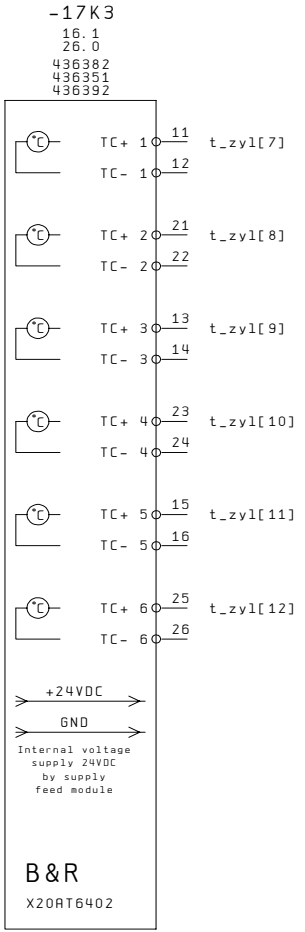
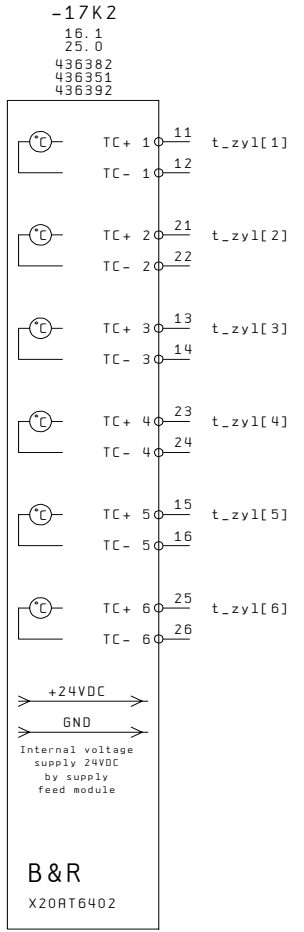
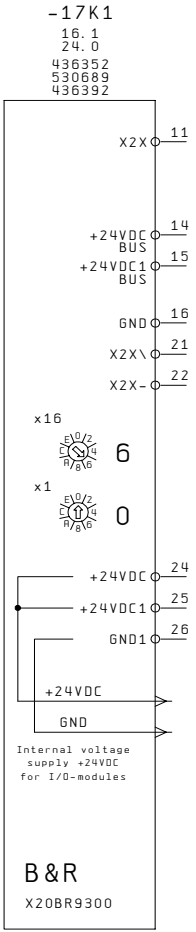

COVER	BR 9300 Busmodul-Receiver
	AT 6402 mV / 6xNICRNI
	AT 6402 mV / 6xNICRNI
	AT 6402 mV / 6xNICRNI
	AT 6402 mV / 6xNICRNI
	AI 4622 / 4x0-20mA
	AI 4622 / 4x0-20mA
	AT 4222 / 4xPT100
	AT 4222 / 4xPT100
	AT 4222 / 4xPT100
	AO 4622 / 4x0-20mA / 0-10V
	DI 9371 / 12x DI
	DI 9371 / 12x DI
	DO 9322 / 12x DO
	DO 9322 / 12x DO
	SM 1426 Schrittmotortreiber
	COVER

			Date	18.01.06	4 x JGS 320 GS-L.L	 Jenbacher gas engines	Over view modules	SD-Nr. Project	8662	
			Desig.	Senfter M.					Suffix	J xxxx
			Print	24.04.12	Nelson Gardens LFG				Wiring diagram	J N795 + M1 / 16
Modific.	Date	Name	Check	Pieschnik A.	DIR: J:\EPLAN4\VP\ANL\BEN\WXXX\N7XX\JN795.P	KW 12 - 2012	EPLAN 5			

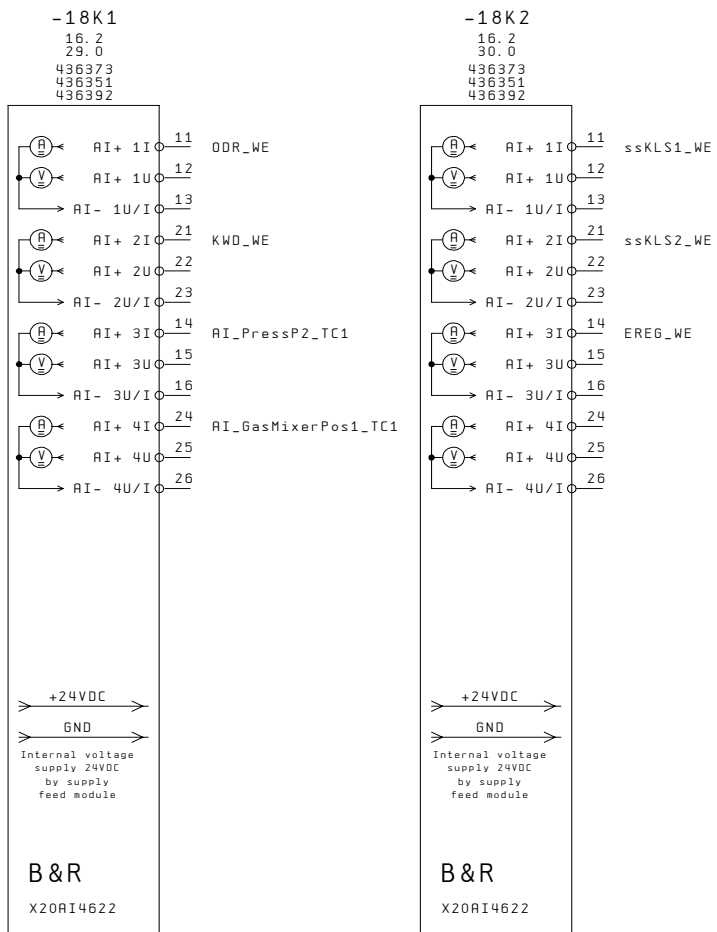

		Date	18.01.06	4 x JGS 320 GS-L.L		Jenbacher gas engines	Slot address Over view		SD-Nr. Project	8662
		Desig.	Senfter M.	Nelson Gardens LFG			Suffix	J xxxx		
		Print	24.04.12				Wiring diagram	J N795 + M1 / 17		
Modific.	Date	Name	Check	Pieschnik A.	DIR: J:\EPLAN4\VP\ANL\BEN\WXXX\N7XX\JN795.P	KW 12 - 2012	EPLAN 5			



		Date	18.01.06	4 x JGS 320 GS-L.L	 Jenbacher gas engines	Slot address Over view	SD-Nr. Project	8662
		Desig.	Senfter M.	Nelson Gardens LFG			Suffix	J xxxx
		Print	24.04.12				Wiring diagram	J N795 + M1 / 18
Modific.	Date	Name	Check	Pieschnik A.	DIR: J:\EPLAN4\VP\ANL\BEN\WXXX\N7XX\JN795.P	KW 12 - 2012	EPLAN 5	

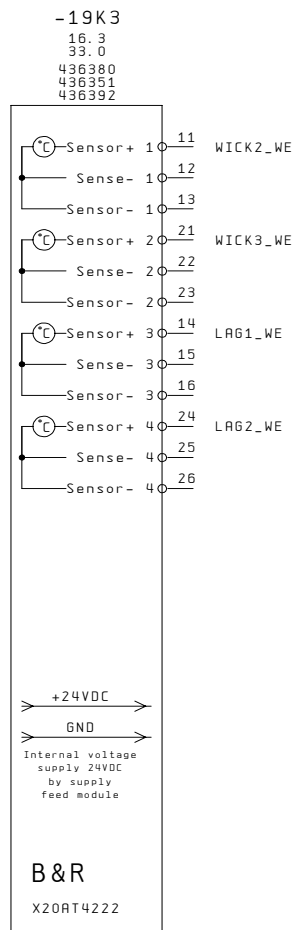
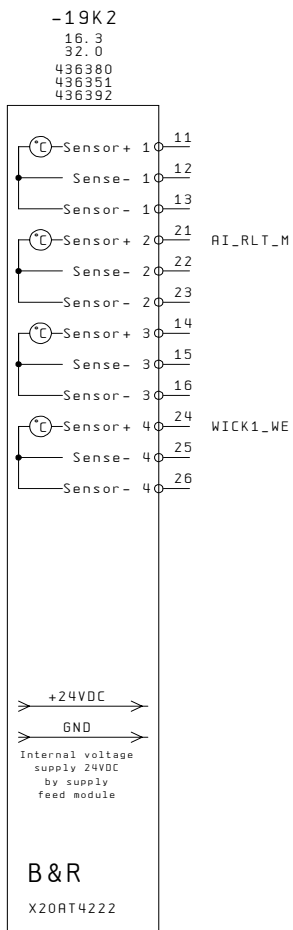
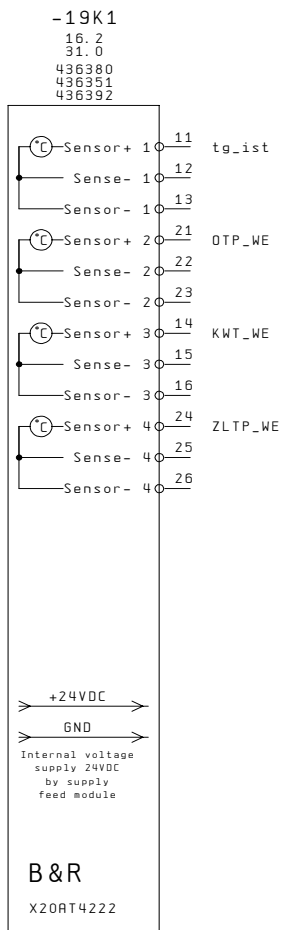

		Date	18.01.06	4 x JGS 320 GS-L.L	Jenbacher gas engines	Slot address Over view	SD-Nr. Project	8662
		Desig.	Senfter M.	Nelson Gardens LFG			Suffix	J xxxx
		Print	24.04.12				Wiring diagram	J N795 + M1 / 19
Modific.	Date	Name	Check	Pieschnik R.	DIR: J:\EPLAN4\VP\ANL\BEN\WXXX\N7XX\JN795.P	KW 12 - 2012	EPLAN 5	

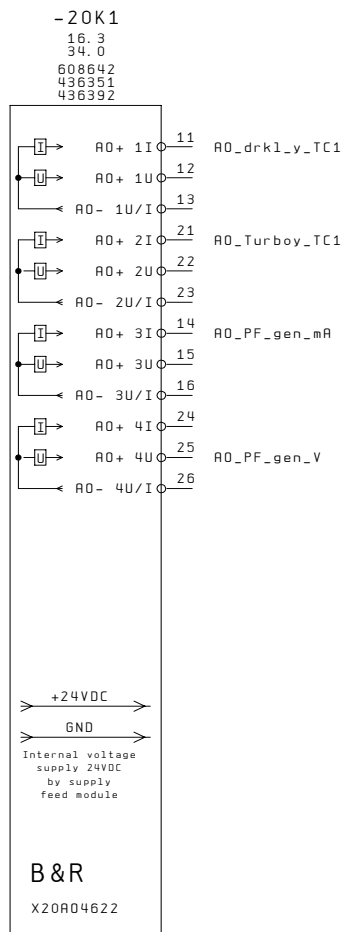

		Date	18.01.06	4 x JGS 320 GS-L.L	 Jenbacher gas engines	Slot address Over view	SD-Nr. Project	8662
		Desig.	Senfter M.	Nelson Gardens LFG			Suffix	J xxxx
		Print	24.04.12				Wiring diagram	J N795 + M1 / 20
Modific.	Date	Name	Check	Pieschnik A.	DIR: J:\EPLAN4\P\ANL\BEN\WXXX\N7XX\JN795.P	KW 12 - 2012	EPLAN 5	

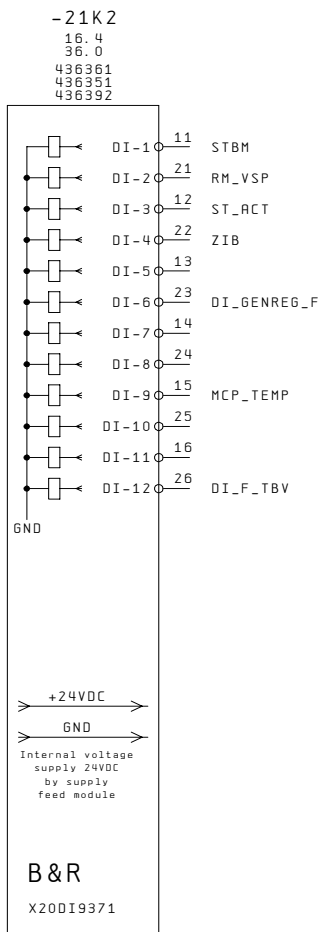
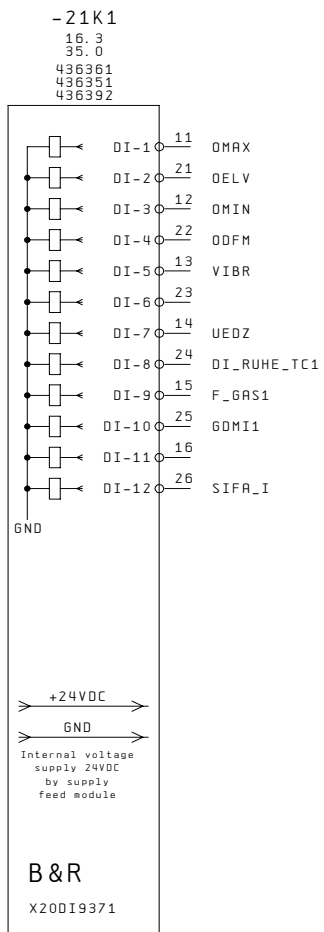

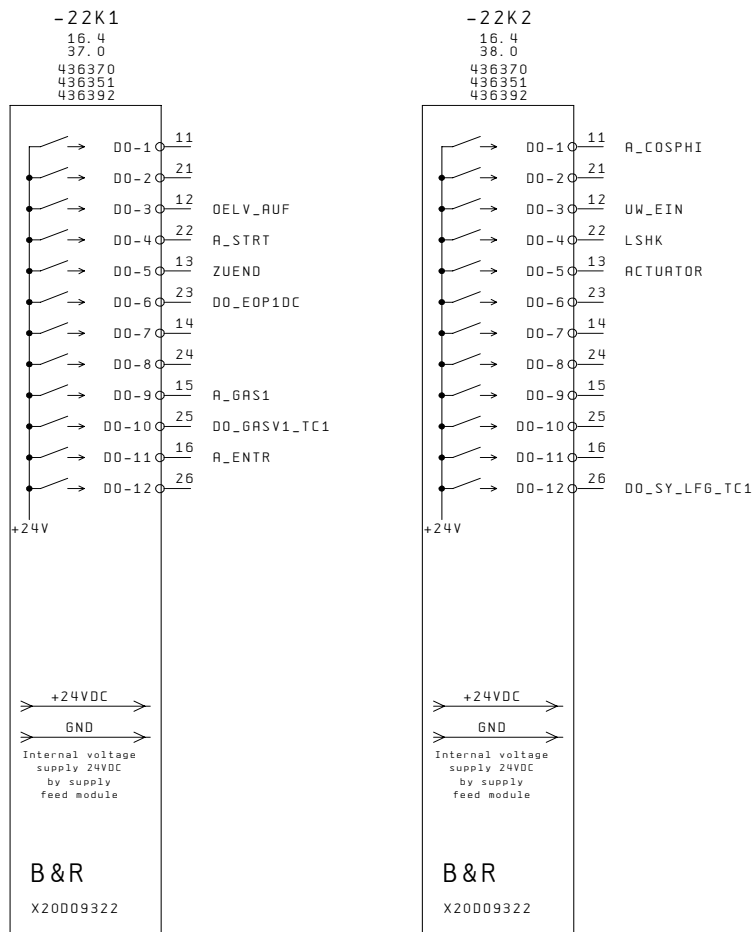

		Date	18.01.06	4 x JGS 320 GS-L.L	Jenbacher gas engines Slot address Over view	SD-Nr. Project	8662
		Desig.	Senfter M.	Nelson Gardens LFG		Suffix	J xxxx
		Print	24.04.12			Wiring diagram	J N795 + M1 / 21
Modific.	Date	Name	Check	Pieschnik A.	DIR: J:\EPLAN4\VP\ANL\BEN\WXXX\N7XX\JN795.P	KW 12 - 2012	EPLAN 5

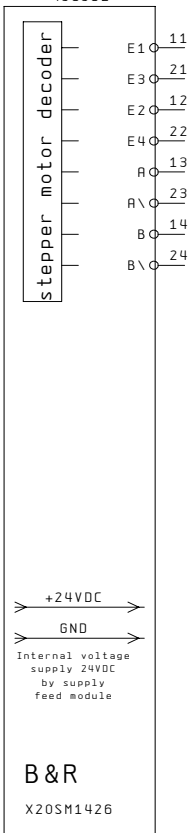

		Date	18.01.06	4 x JGS 320 GS-L.L	 Jenbacher gas engines	Slot address Over view		SD-Nr. Project	8662
		Desig.	Senfter M.	Nelson Gardens LFG		Suffix	J xxxx		
		Print	24.04.12			Wiring diagram	J N795 + M1 / 22		
Modific.	Date	Name	Check	Pieschnik A.	DIR: J:\EPLAN4\VP\ANL\BEN\WXXX\N7XX\JN795.P	KW 12 - 2012	EPLAN 5		

-23K1
 16.4
 39.0
 540595
 436351
 436392



		Date	18.01.06	4 x JGS 320 GS-L.L	 Jenbacher gas engines	Slot address Over view	SD-Nr. Project	8662
		Desig.	Senfter M.	Nelson Gardens LFG			Suffix	J xxxx
		Print	24.04.12				Wiring diagram	J N795 + M1 / 23
Modific.	Date	Name	Check	Pieschnik A.	DIR: J:\EPLAN4\P\ANL\GEN\XXXX\N7XX\JN795.P	KW 12 - 2012	EPLAN 5	

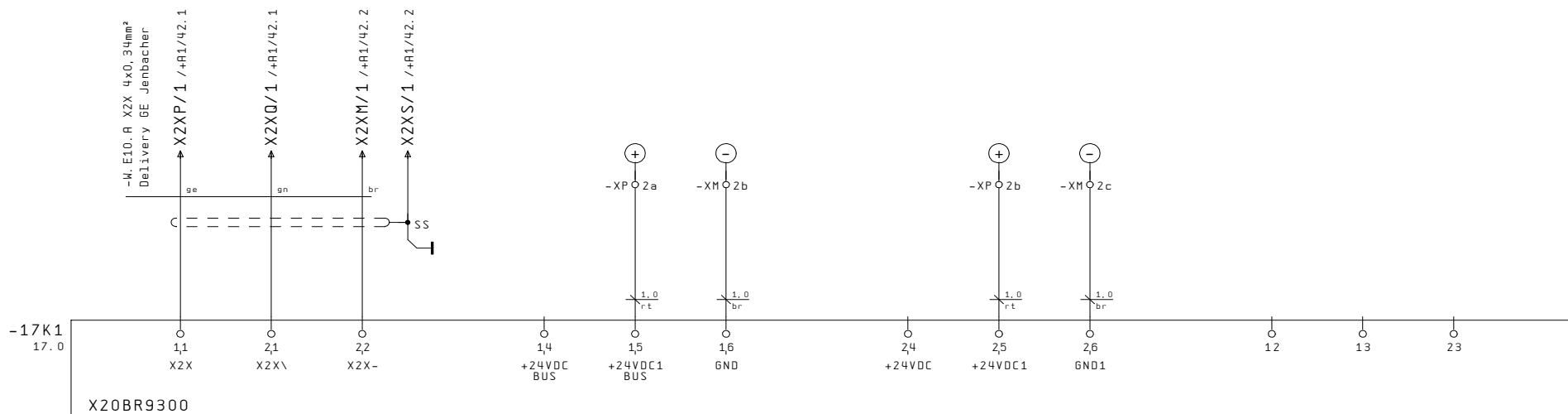

X2X ----> Module control panel

Supply PLC

		Date	18.01.06	4 x JGS 320 GS-L.L	 Jenbacher gas engines	BUS-RECEIVER	SD-Nr.	8662
		Desig.	Senfter M.	Nelson Gardens LFG			Suffix	J xxxx
		Print	24.04.12				Wiring diagram	J N795 + M1 / 24
Modific.	Date	Name	Check	Pieschnik A.	DIR: J:\EPLAN4\P\ANL\GEN\WXXX\N7XX\JN795.P	KW 12 - 2012	EPLAN 5	

Cylinder: 1

2

3

4

5

6

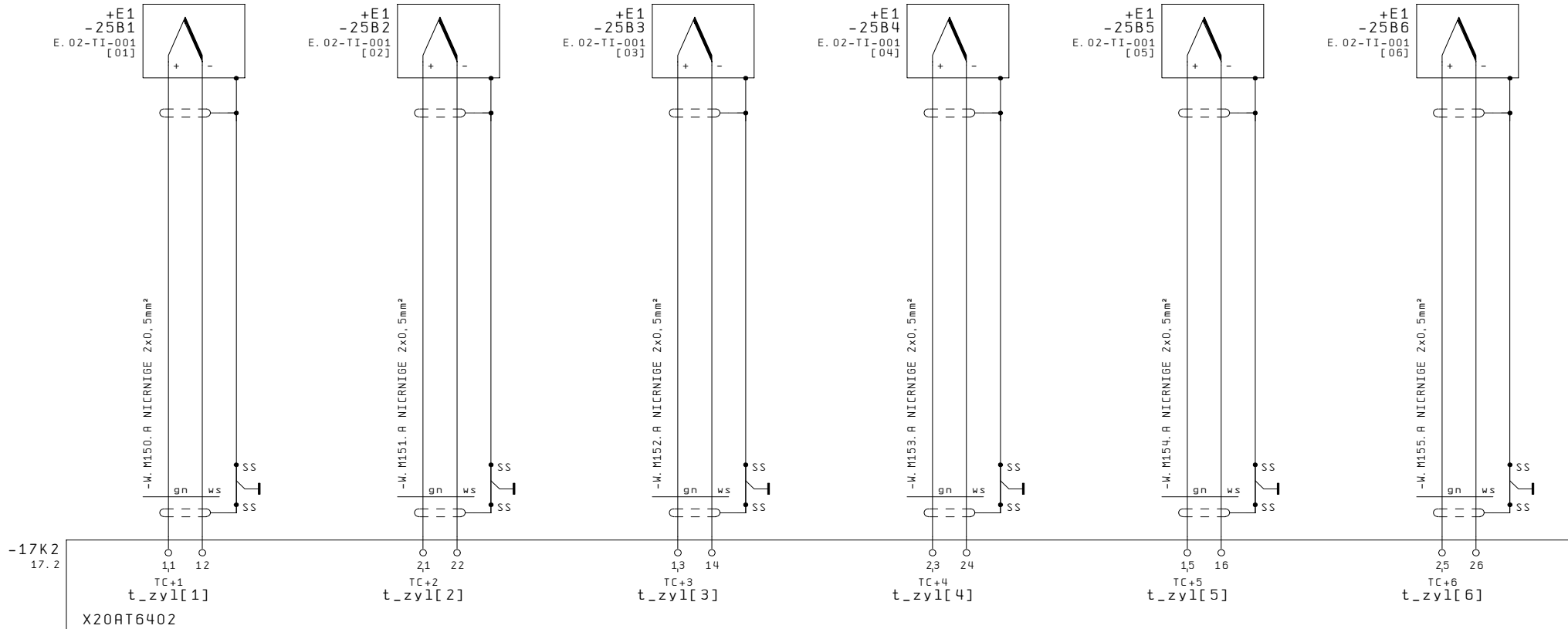

		Date	18.01.06	4 x JGS 320 GS-L.L	 Jenbacher gas engines	Analog Inputs	SD-Nr. Project	8662
		Desig.	Senfter M.	Nelson Gardens LFG			Suffix	J xxxx
		Print	24.04.12				Wiring diagram	J N795 + M1 / 25
Modific.	Date	Name	Check	Pieschnik A.	DIR: J:\EPLAN4\VP\ANL\BEN\WXXX\N7XX\JN795.P	KW 12 - 2012	EPLAN 5	

Cylinder: 7

8

9

10

11

12

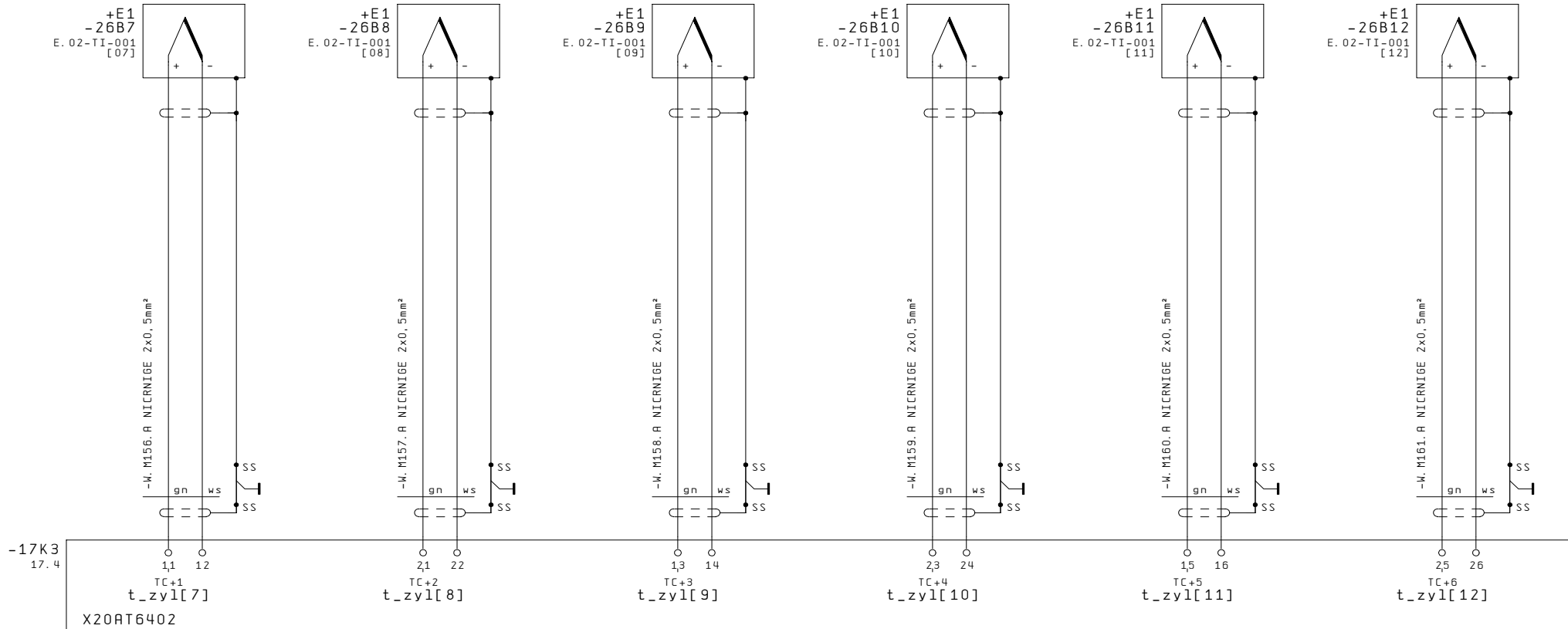

		Date	18.01.06	4 x JGS 320 GS-L.L		 Jenbacher gas engines	Analog Inputs		SD-Nr. Project	8662
		Desig.	Senfter M.	Nelson Gardens LFG			Suffix	J xxxx		
		Print	24.04.12				Wiring diagram	J N795 + M1 / 26		
Modific.	Date	Name	Check	Pieschnik A.	DIR: J:\EPLAN4\VP\ANLARGEN\WXXX\N7XX\JN795.P	KW 12 - 2012	EPLAN 5			

Cylinder: 13

14

15

16

17

18

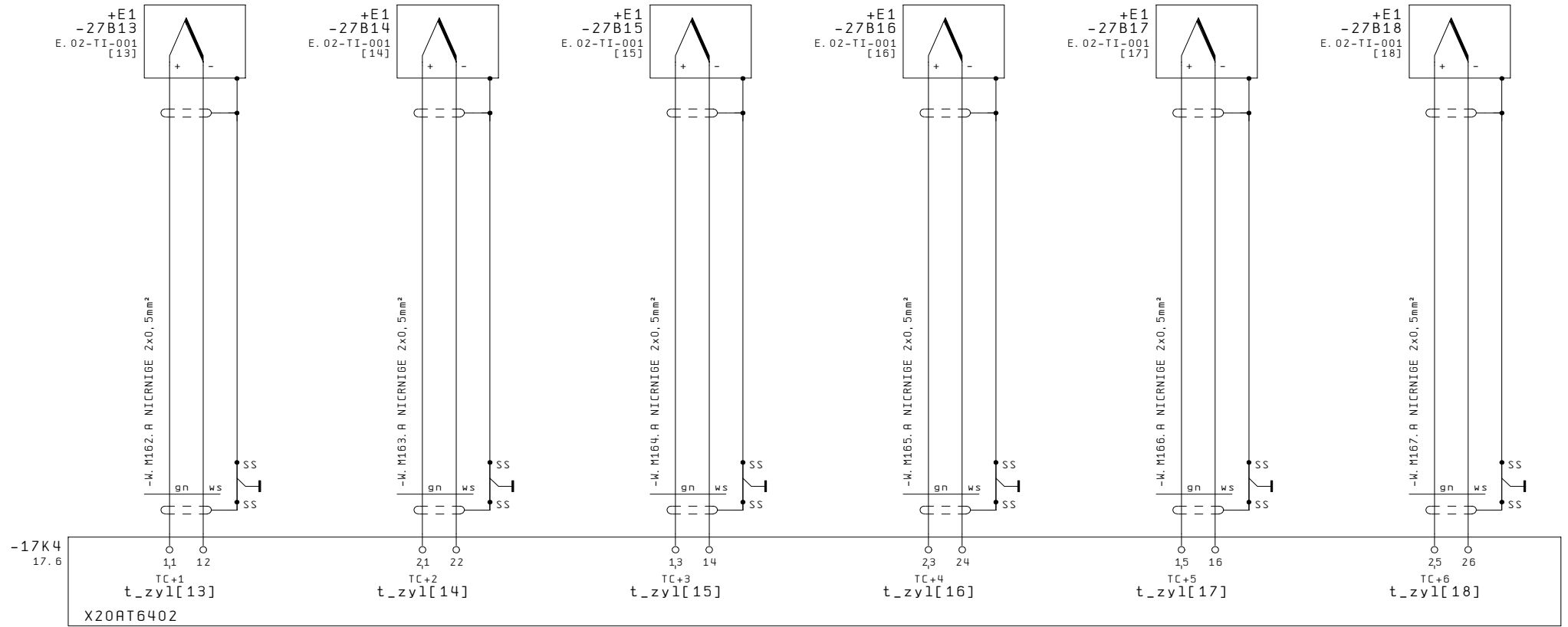

		Date	18.01.06	4 x JGS 320 GS-L.L		 Jenbacher gas engines	Analog Inputs		SD-Nr.	8662	
		Desig.	Senfter M.	Nelson Gardens LFG			Suffix	J xxxx			
		Print	24.04.12				Wiring diagram	J N795 + M1		/	27
Modific.	Date	Name	Check	Pieschnik A.	DIR: J:\EPLAN4\VP\ANLARBEN\WXXX\N7XX\JN795.P		KW 12 - 2012		EPLAN 5		

Cylinder: 19

20

+E1
-28B19
E. 02-TI-001
[19]

+E1
-28B20
E. 02-TI-001
[20]

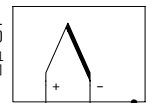
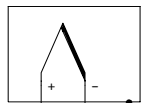

-W. M168. R NICKNIGE 2x0,5mm²

-W. M169. R NICKNIGE 2x0,5mm²

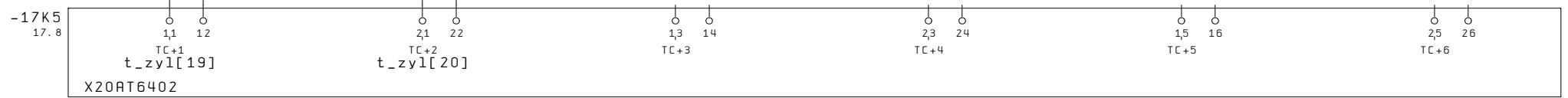
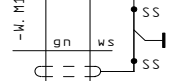
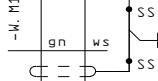

Spare

Spare

Spare

Spare

		Date	18.01.06	4 x JGS 320 GS-L.L	 Jenbacher gas engines	Analog Inputs	SD-Nr. Project	8662
		Desig.	Senfter M.	Nelson Gardens LFG			Suffix	J xxxx
		Print	24.04.12				Wiring diagram	J N795 + M1 / 28
Modific.	Date	Name	Check	Pieschnik R.	DIR: J:\EPLAN4\VP\ANLARBEN\WXXX\N7XX\JN795.P	KW 12 - 2012	EPLAN 5	

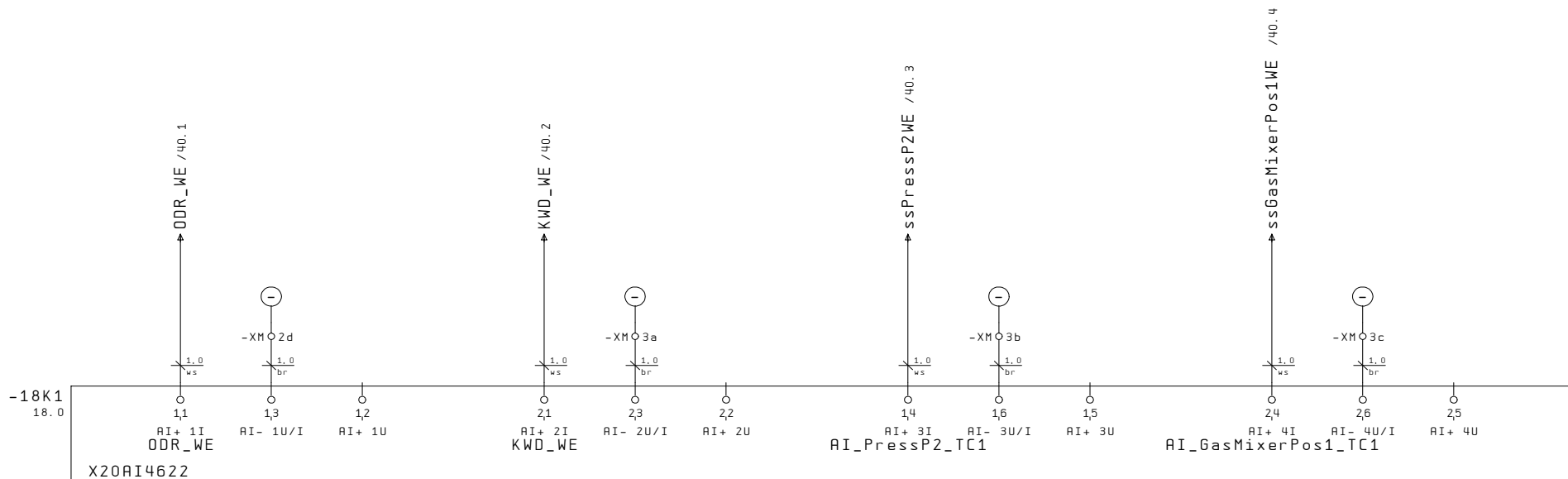

Oil pressure

Jacket water pressure

Supercharge pressure

Mixer position

		Date	18.01.06	4 x JGS 320 GS-L.L	 Jenbacher gas engines	Analog Inputs	SD-Nr. Project	8662
		Desig.	Senfter M.	Nelson Gardens LFG			Suffix	J xxxx
		Print	24.04.12				Wiring diagram	J N795 + M1 / 29
Modific.	Date	Name	Check	Pieschnik A.	DIR: J:\EPLAN4\P\ANL\GEN\WXXX\N7XX\JN795.P	KW 12 - 2012	EPLAN 5	

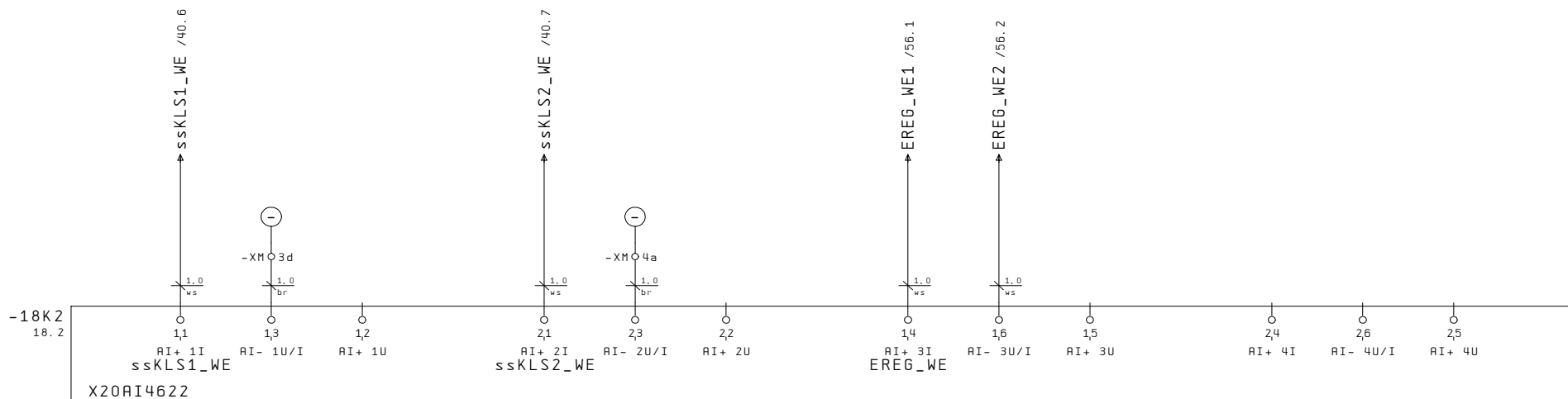

Knocking detector 1

Knocking detector 2

Excitation voltage Generator

Spare

		Date	18.01.06	4 x JGS 320 GS-L.L	 Jenbacher gas engines	Analog Inputs		SD-Nr. Project	8662	
		Desig.	Senfter M.	Nelson Gardens LFG		Suffix	J xxxx			
		Print	24.04.12							
Modific.	Date	Name	Check	Pieschnik R.	DIR: J:\EPLAN4\P\ANL\BEN\NXXX\N7XX\JN795.P	KW 12 - 2012	EPLAN 5	Wiring diagram	J N795 + M1 / 30	

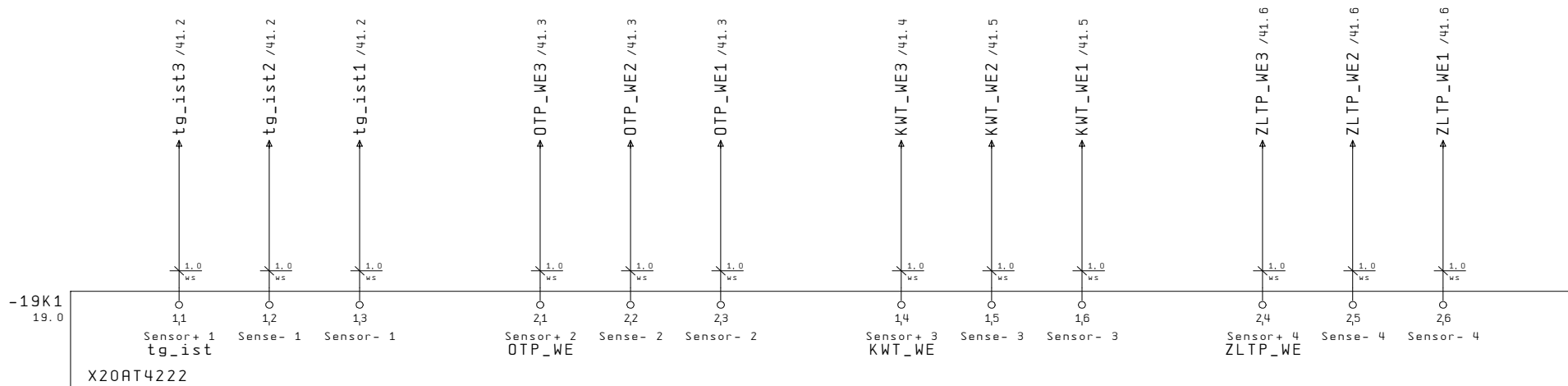

-19K1
19.0

Fuel mixture temperature

Oil temperature

Engine jacket water temperature

Intake air temperature

		Date	18.01.06	4 x JGS 320 GS-L.L	 Jenbacher gas engines	Analog Inputs	SD-Nr. Project	8662
		Desig.	Senfter M.	Nelson Gardens LFG			Suffix	J xxxx
		Print	24.04.12				Wiring diagram	J N795 + M1 / 31
Modific.	Date	Name	Check	Pieschnik A.	DIR: J:\EPLAN4\P\ANL\BEN\WXXX\N7XX\JN795.P	KW 12 - 2012	EPLAN 5	

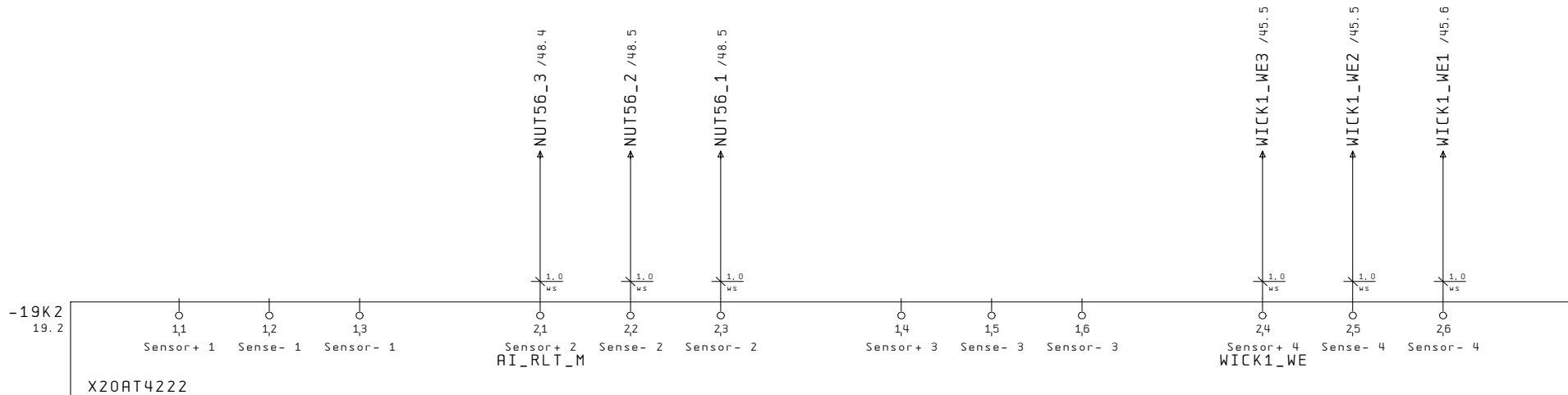

Water return Temperature

Gas engine:
Water return Temperature

Spare

Windings temperature

		Date	18.01.06	4 x JGS 320 GS-L.L	 Jenbacher gas engines	Analog Inputs	SD-Nr. Project	8662
		Desig.	Senfter M.	Nelson Gardens LFG			Suffix	J xxxx
		Print	24.04.12				Wiring diagram	J N795 + M1 / 32
Modific.	Date	Name	Check	Pieschnik A.	DIR: J:\EPLAN4\P\ANL\BEN\WXXX\N7XX\JN795.P	KW 12 - 2012	EPLAN 5	

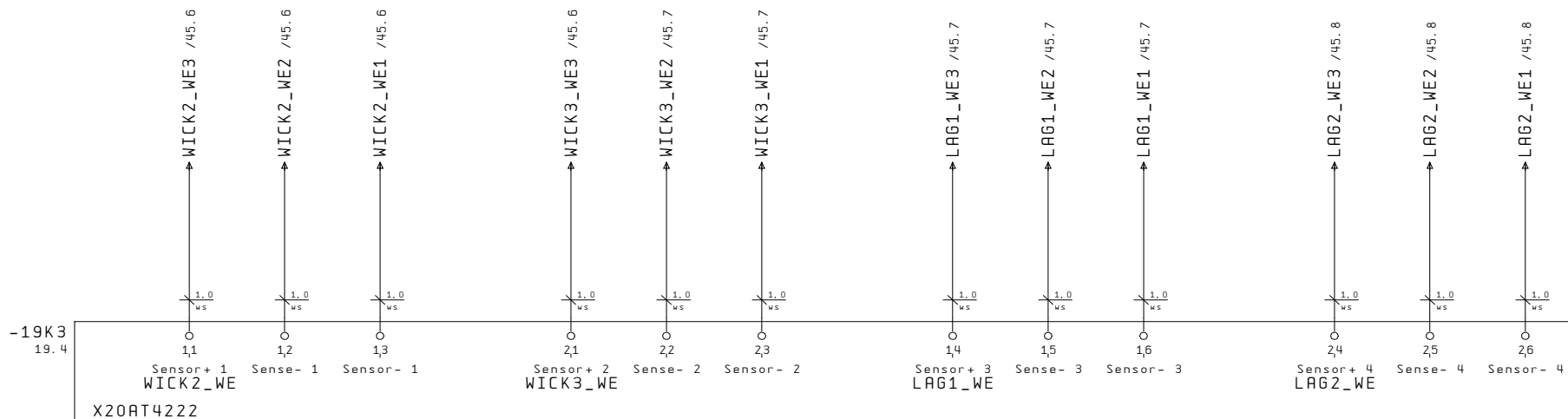

-19K3
19.4

Windings temperature
Phase V

Windings temperature
Phase W

Bearing temperature DE

Bearing temperature NDE

		Date	18.01.06	4 x JGS 320 GS-L.L	 Jenbacher gas engines	Analog Inputs	SD-Nr. Project	8662
		Desig.	Senfter M.	Nelson Gardens LFG			Suffix	J xxxx
		Print	24.04.12				Wiring diagram	J N795 + M1 / 33
Modific.	Date	Name	Check	Pieschnik A.	DIR: J:\EPLAN4\VP\ANL\BEN\WXXX\N7XX\JN795.P	KW 12 - 2012	EPLAN 5	

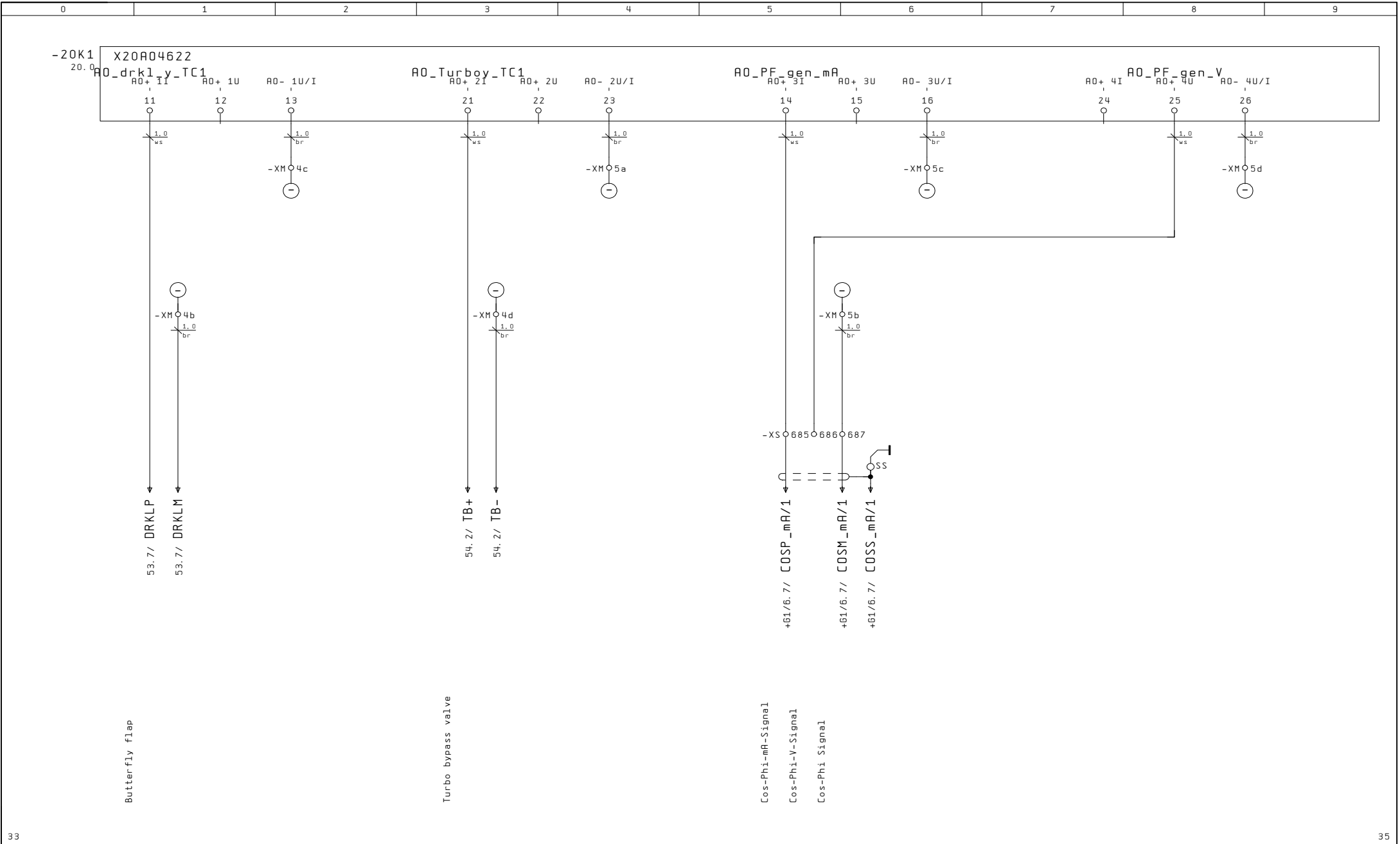

		Date	18.01.06	4 x JGS 320 GS-L.L	 Jenbacher gas engines	Analog Outputs	SD-Nr. Project	8662
		Desig.	Senfter M.	Nelson Gardens LFG			Suffix	J xxxx
		Print	24.04.12				Wiring diagram	J N795 + M1 / 34
Modific.	Date	Name	Check	Pieschnik A.	DIR: J:\EPLAN4\VP\ANLAGEN\WXXX\N7XX\JN795.P	KW 12 - 2012	EPLAN 5	

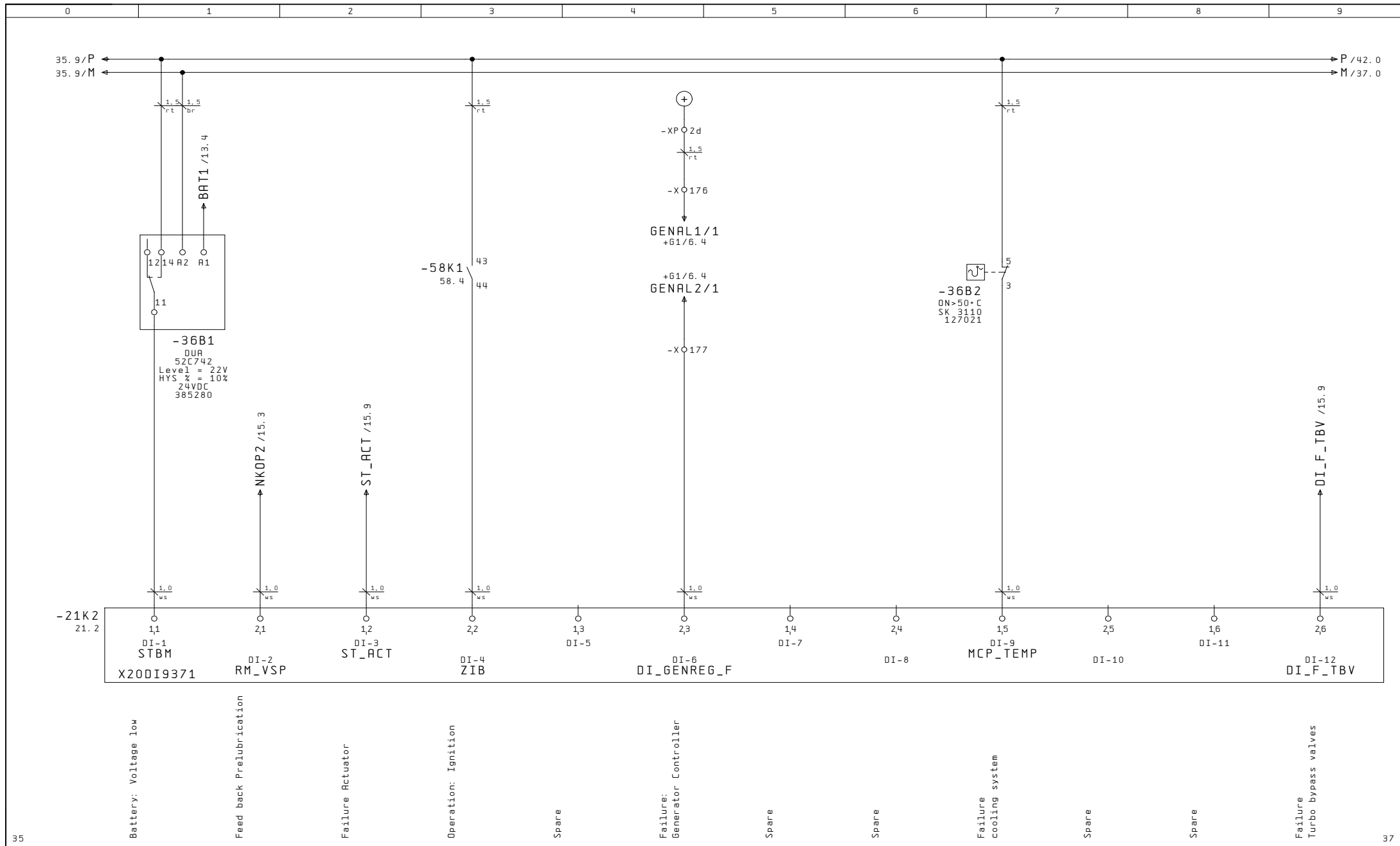



Modific.	Date	Name	Check	Pieschnik A.	DIR: J:\EPLAN4\VP\ANL\BEN\WXXX\N7XX\N795.P	KW 12 - 2012	EPLAN 5	Digital Inputs	SD-Nr. Project	8662
									Suffix	J xxxx
									Wiring diagram	J N795 + M1 / 36



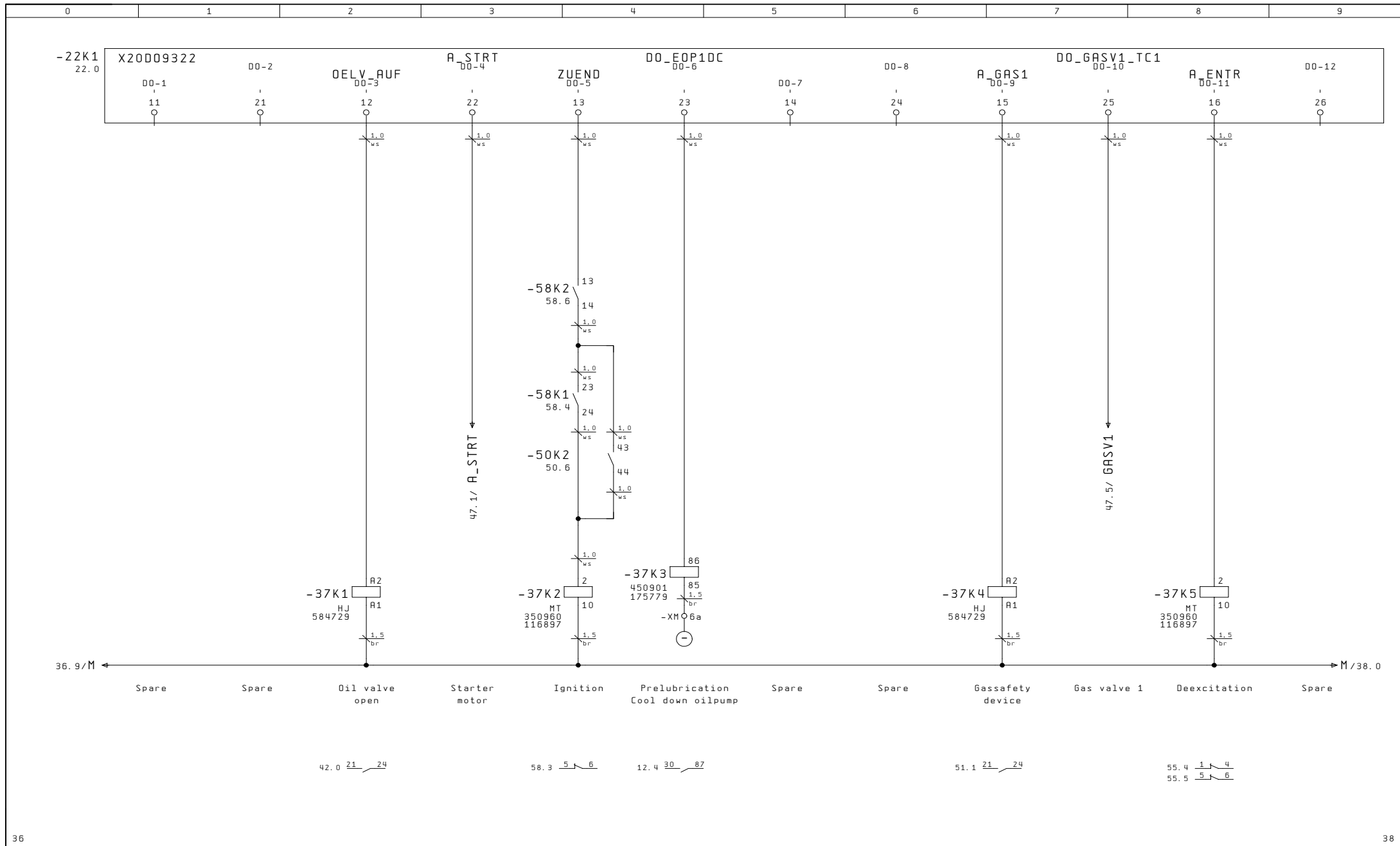

Jenbacher
gas engines

4 x JGS 320 GS-L.L
Nelson Gardens LFG

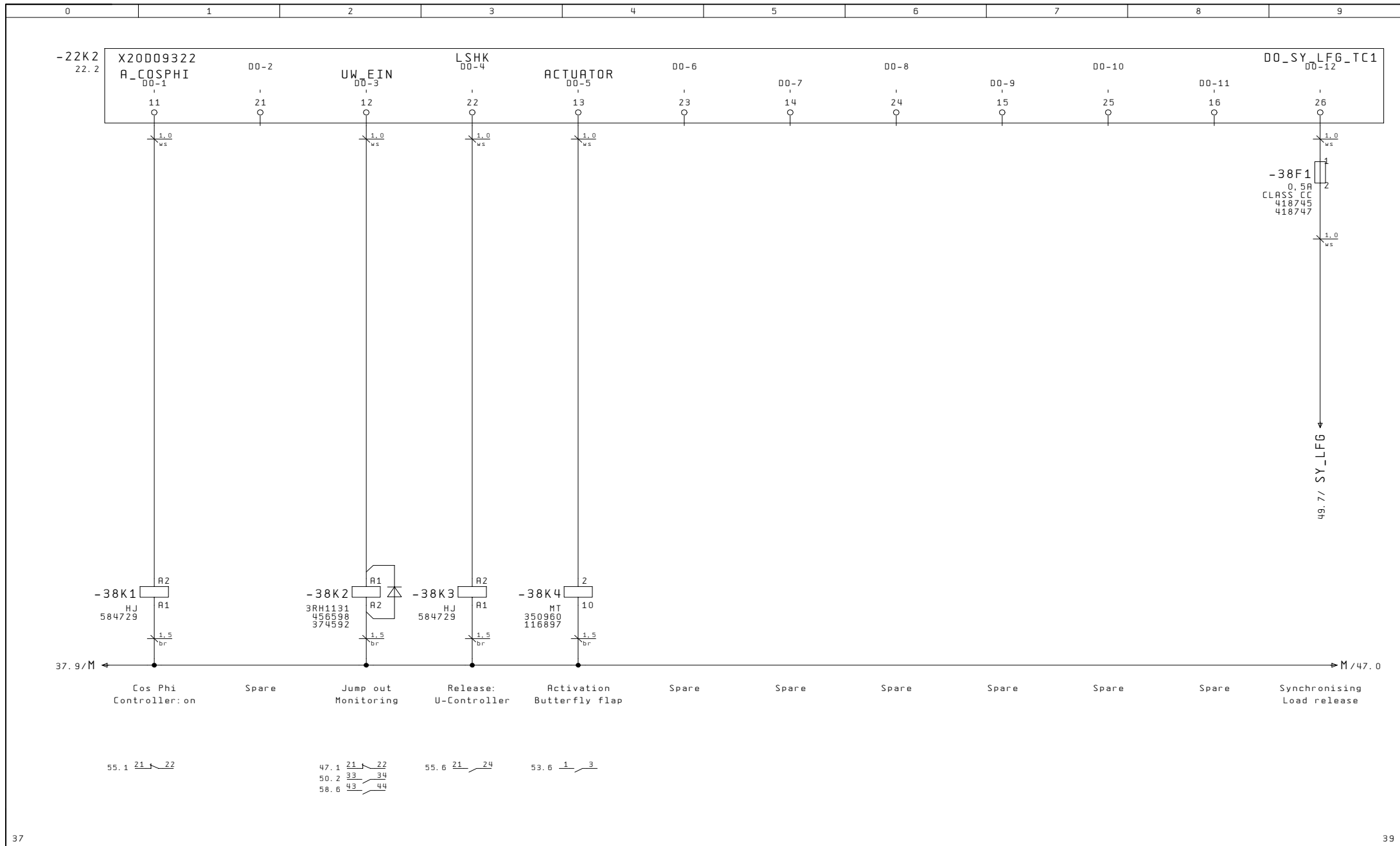

		Date	18.01.06	4 x JGS 320 GS-L.L	 Jenbacher gas engines	Digital Outputs	SD-Nr.-Project	8662
		Desig.	Senfter M.	Nelson Gardens LFG			Suffix	J xxxx
		Print	24.04.12				Wiring diagram	J N795 + M1 / 37
Modific.	Date	Name	Check	Pieschnik A.	DIR: J:\EPLAN4\VP\ANL\BEN\WXXX\N7XX\JN795.P	KW 12 - 2012	EPLAN 5	



		Date	18.01.06	4 x JGS 320 GS-L.L	 Jenbacher gas engines	Digital Outputs	SD-Nr. Project	8662
		Desig.	Senfter M.	Nelson Gardens LFG		Suffix	J xxxx	
		Print	24.04.12			Wiring diagram	J N795 + M1 / 38	
Modific.	Date	Name	Check	Pieschnik A.	DIR: J:\EPLAN4\VP\ANL\BEN\WXXX\N7XX\JN795.P	KW 12 - 2012	EPLAN 5	

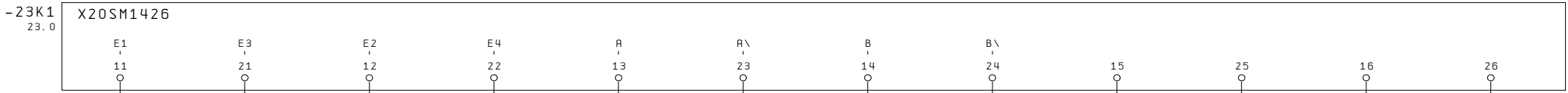

Spare

Spare

Spare

Spare

Air-gas mixer motor P1

Spare

Spare

Spare

Spare

		Date	18.01.06	4 x JGS 320 GS-L.L	 Jenbacher gas engines	Control: Step motor	SD-Nr. Project	8662
		Desig.	Senfter M.	Nelson Gardens LFG			Suffix	J xxxx
		Print	24.04.12				Wiring diagram	J N795 + M1 / 39
Modific.	Date	Name	Check	Pieschnik A.	DIR: J:\EPLAN4\VP\ANL\BEN\WXXX\N7XX\JN795.P	KW 12 - 2012	EPLAN 5	

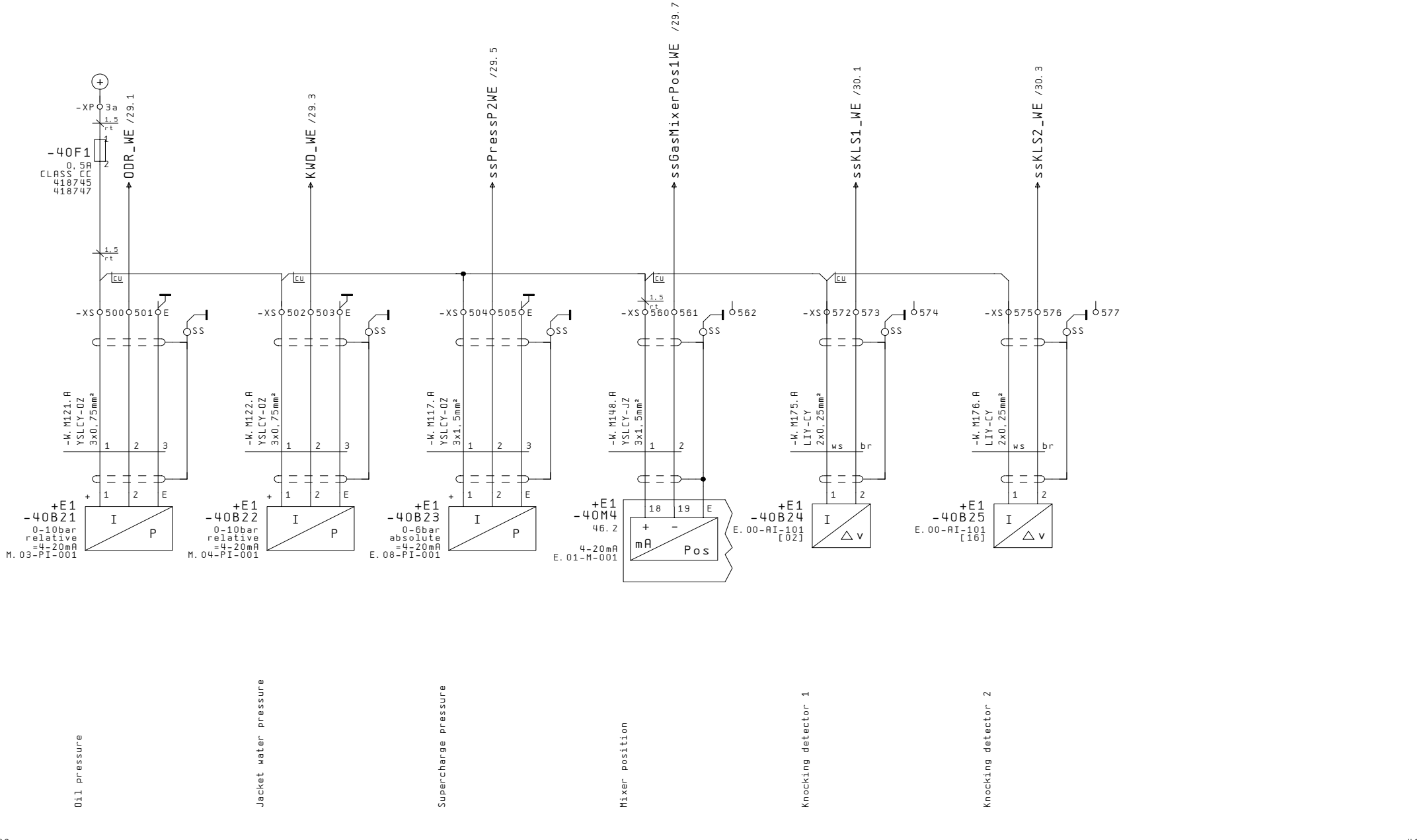

Date		18.01.06		4 x JGS 320 GS-L.L		 Jenbacher gas engines	SD-Nr. Project		8662	
Desig.		Senfter M.		Nelson Gardens LFG			Suffix		J xxxx	
Print		24.04.12		DIR: J:\EPLAN4\VP\ANL\BEN\WXXX\N7XX\JN795.P			Wiring diagram		J N795 + M1 / 40	
Modific.	Date	Name	Check	Pieschnik A.	KW 12 - 2012	EPLAN 5	Sensors Gas engine			

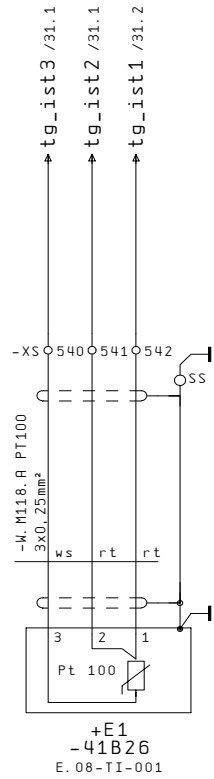

Fuel mixture temperature

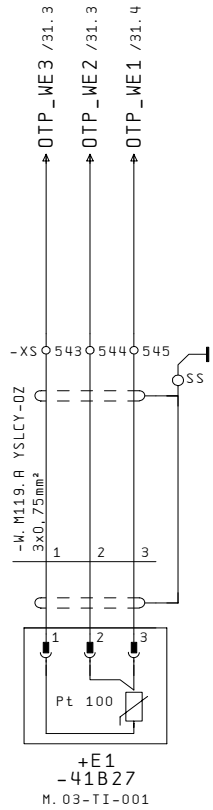

Oil temperature

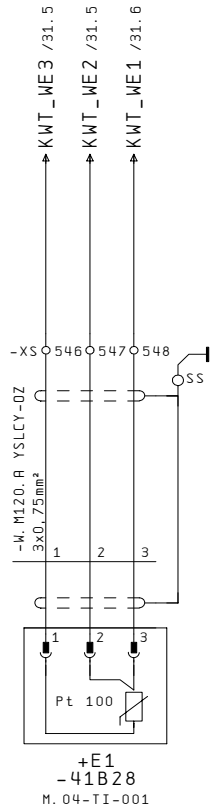

Engine jacket water temperature

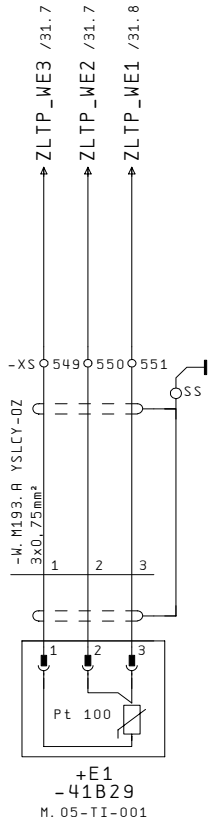

Intake air temperature

		Date	18.01.06	4 x JGS 320 GS-L.L		 Jenbacher gas engines	Sensors Gas engine		SD-Nr. Project	8662
		Desig.	Senfter M.	Nelson Gardens LFG					Suffix	J xxxx
		Print	24.04.12	DIR: J:\EPLAN\4\VP\ANL\BEN\WXXX\N7XX\N795.P			KW 12 - 2012		Wiring diagram	J N795 + M1 / 41
Modific.	Date	Name	Check	Pieschnik A.	EPLAN 5					

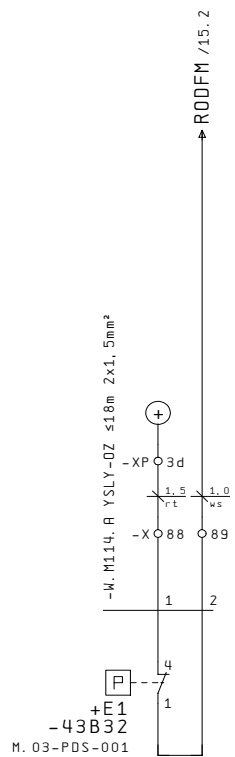

Oil differential pressure
high

		Date	18.01.06	4 x JGS 320 GS-L.L	 Jenbacher gas engines	Monitoring: Gas engine	SD-Nr. Project	8662
		Desig.	Senfter M.	Nelson Gardens LFG			Suffix	J xxxx
		Print	24.04.12					Wiring diagram
Modific.	Date	Name	Check	Pieschnik R.	DIR: J:\EPLAN4\VP\ANL\BEN\XXXX\N7XX\JN795.P	KW 12 - 2012	EPLAN 5	

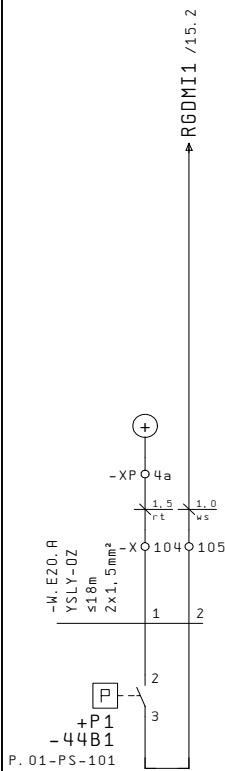

Gas pressure low
Gas train 1

		Date	18.01.06	4 x JGS 320 GS-L.L	 Jenbacher gas engines	Monitoring: Gas pressure	SD-Nr. Project	8662
		Desig.	Senfter M.	Nelson Gardens LFG			Suffix	J xxxx
		Print	24.04.12				Wiring diagram	J N795 + M1 / 44
Modific.	Date	Name	Check	Pieschnik A.	DIR: J:\EPLAN4\VP\ANL\BEN\XXXX\N7XX\JN795.P	KW 12 - 2012	EPLAN 5	

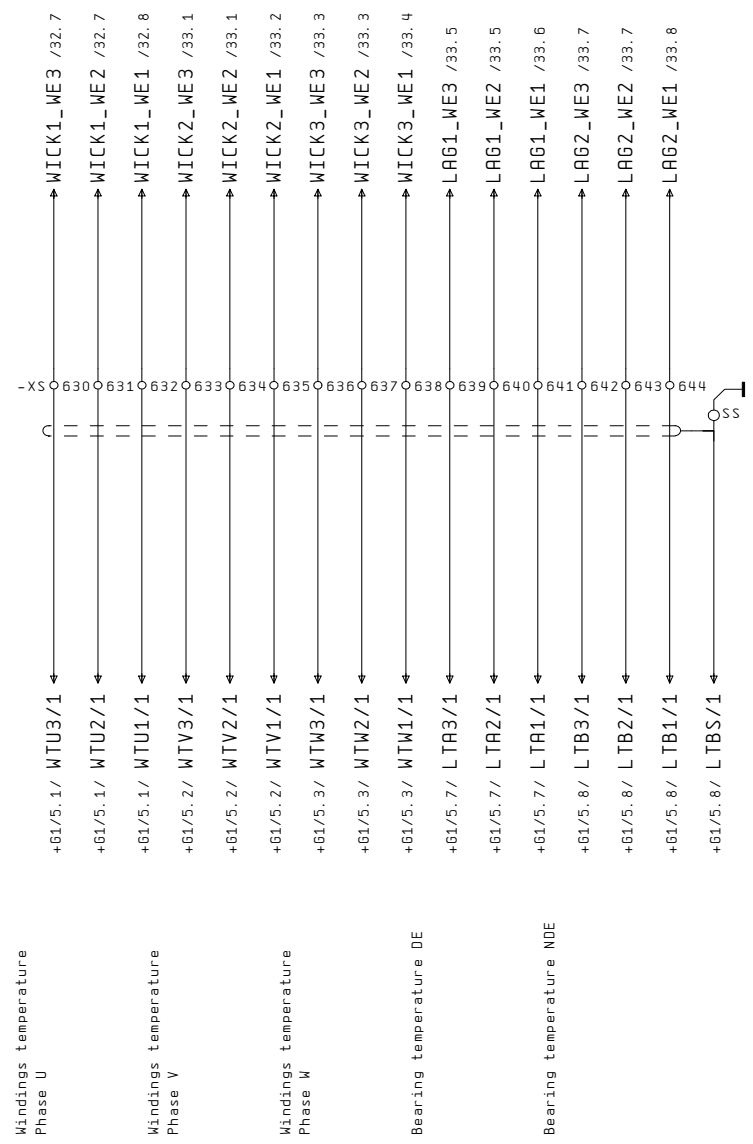

		Date	18.01.06	4 x JGS 320 GS-L.L	 Jenbacher gas engines	Signals <-> Generator	SD-Nr. Project	8662
		Desig.	Senfter M.	Nelson Gardens LFG			Suffix	J xxxx
		Print	24.04.12				Wiring diagram	J N795 + M1 / 45
Modific.	Date	Name	Check	Pieschnik A.	DIR: J:\EPLAN4\VP\ANL\BEN\WXXX\N7XX\JN795.P	KW 12 - 2012	EPLAN 5	

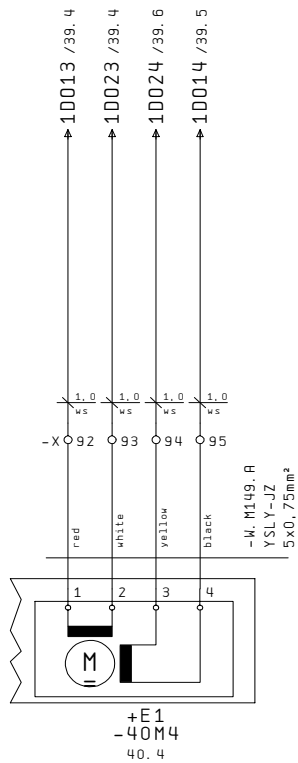

Air-gas mixer P1

		Date	18.01.06	4 x JGS 320 GS-L.L	 Jenbacher gas engines	SD-Nr. Project	8662
		Desig.	Senfter M.	Nelson Gardens LFG		Suffix	J xxxx
		Print	24.04.12			Wiring diagram	J N795 + M1 / 46
Modific.	Date	Name	Check	Pieschnik A.	DIR: J:\EPLAN4\VP\ANL\BEN\WXXX\N7XX\JN795.P	KW 12 - 2012	EPLAN 5

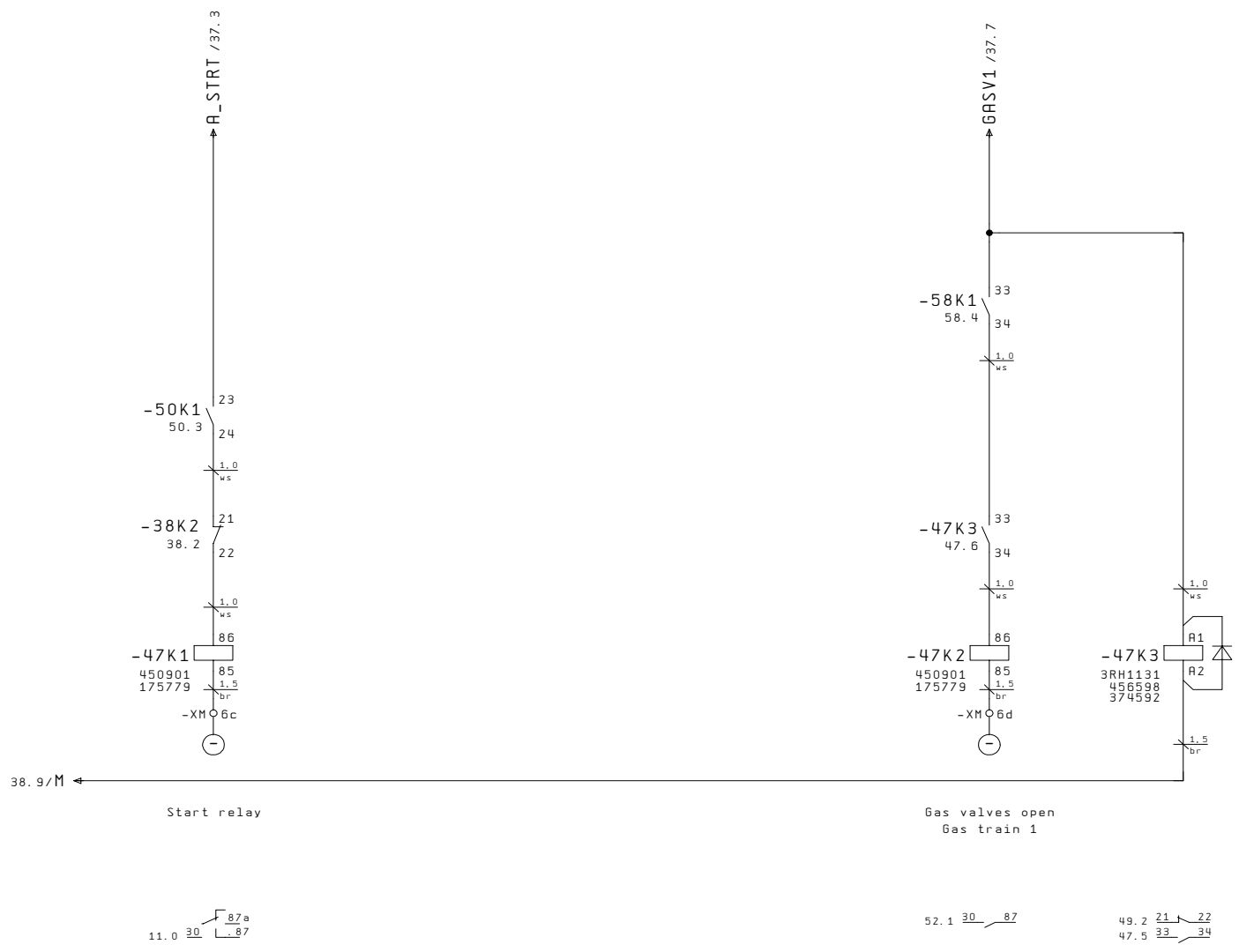

Start relay

Gas valves open
Gas train 1

		Date	18.01.06	4 x JGS 320 GS-L.L	 Jenbacher gas engines	Control Gas engine	SD-Nr.	8662
		Desig.	Senfter M.	Nelson Gardens LFG			Suffix	J xxxx
		Print	24.04.12				Wiring diagram	J N795 + M1 / 47
Modific.	Date	Name	Check	Pieschnik A.	DIR: J:\EPLAN4\VP\ANL\BEN\WXXX\N7XX\JN795.P	KW 12 - 2012	EPLAN 5	

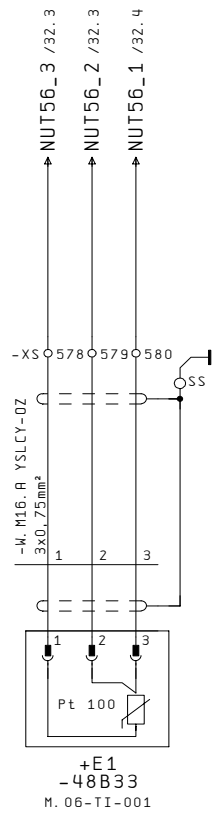

Gas engine:
Water return Temperature

		Date	18.01.06	4 x JGS 320 GS-L.L	 Jenbacher gas engines	Temperature sensor	SD-Nr. Project	8662
		Desig.	Senfter M.	Nelson Gardens LFG			Suffix	J xxxx
		Print	24.04.12				Wiring diagram	J N795 + M1 / 48
Modific.	Date	Name	Check	Pieschnik A.	DIR: J:\EPLAN4\VP\ANL\BEN\WXXX\N7XX\JN795.P	KW 12 - 2012	EPLAN 5	



Emergency stop

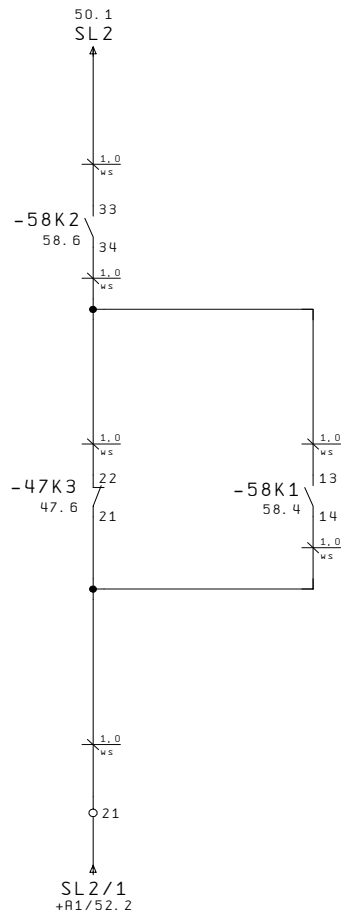

Emergency stop Push button

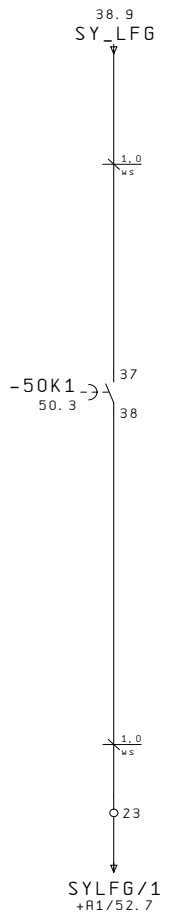
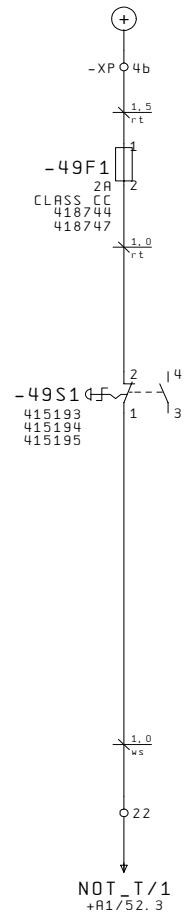

Synchronising Load release

		Date	18.01.06	4 x JGS 320 GS-L.L	 Jenbacher gas engines	Emergency stop	SD-Nr. Project	8662
		Desig.	Senfter M.	Nelson Gardens LFG		Suffix	J xxxx	
		Print	24.04.12			Wiring diagram	J N795 + M1 / 49	
Modific.	Date	Name	Check	Pieschnik A.	DIR: J:\EPLAN4\VP\ANL\BEN\WXXX\N7XX\JN795.P	KW 12 - 2012	EPLAN 5	

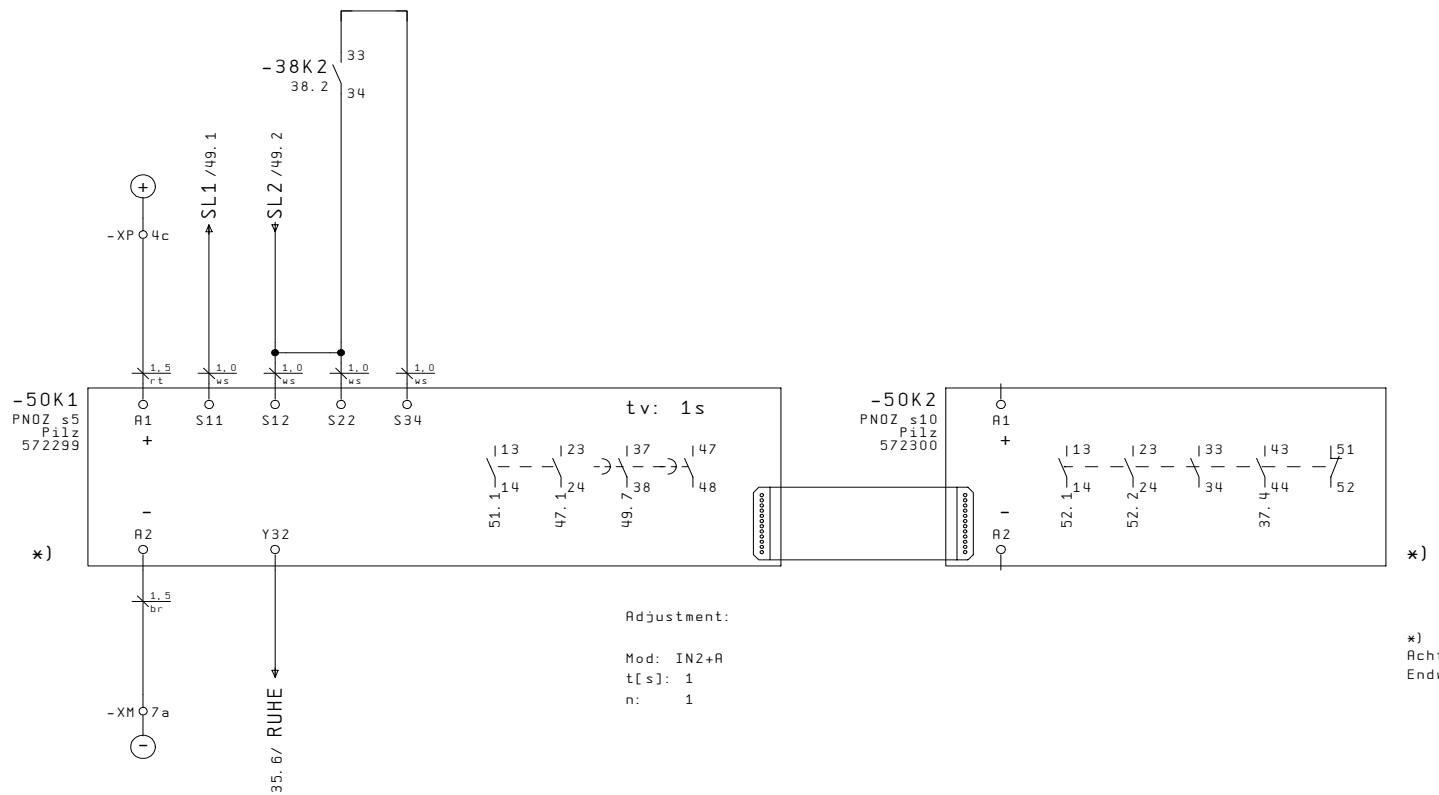

*)

*)

*)
Achtung:
Endwinkel einbauen !

Emergency stop Relay

		Date	18.01.06	4 x JGS 320 GS-L.L	 Jenbacher gas engines	Emergency stop Relay	SD-Nr. Project	8662
		Desig.	Senfter M.	Nelson Gardens LFG			Suffix	J xxxx
		Print	24.04.12				Wiring diagram	J N795 + M1 / 50
Modific.	Date	Name	Check	Pieschnik A.	DIR: J:\EPLAN4\VP\ANLAGEN\NXXX\N7XX\N795.P	KW 12 - 2012	EPLAN 5	

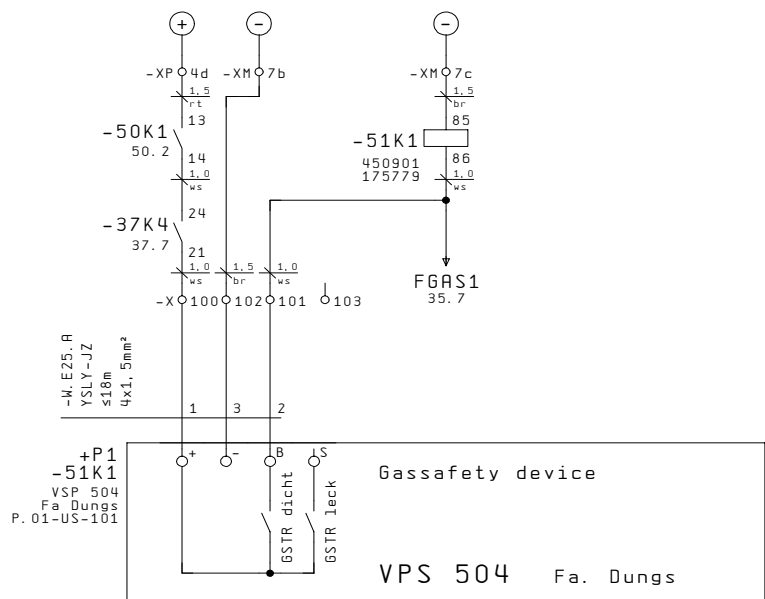

52.1 30 87

Gassafety device 1

		Date	18.01.06	4 x JGS 320 GS-L.L	 Jenbacher gas engines	1 Gas train	SD-Nr. Project	8662
		Desig.	Senfter M.	Nelson Gardens LFG		Suffix	J xxxx	
		Print	24.04.12			Wiring diagram	J N795 + M1 / 51	
Modific.	Date	Name	Check	Pieschnik A.	DIR: J:\EPLAN4\VP\ANL\BEN\WXXX\N7XX\JN795.P	KW 12 - 2012	EPLAN 5	

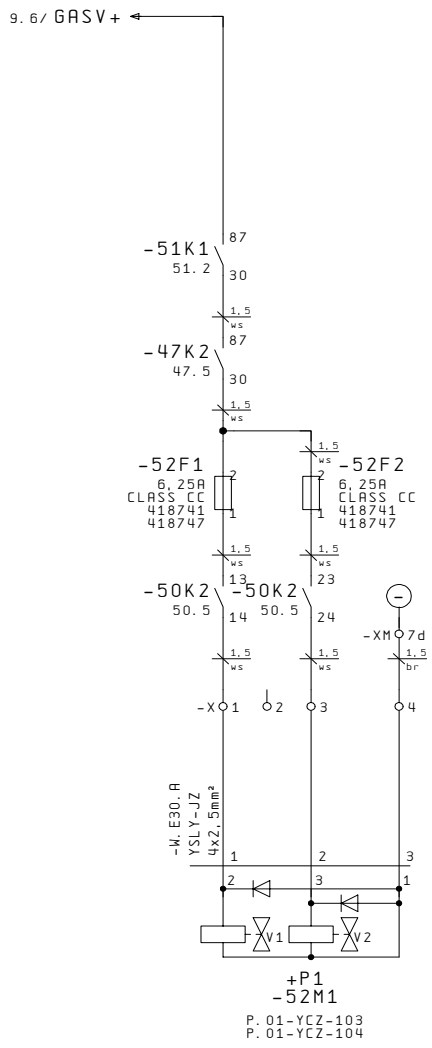

Gas valve 1
Gas train 1

		Date	18.01.06	4 x JGS 320 GS-L.L	 Jenbacher gas engines	Gas valves	SD-Nr. Project	8662
		Desig.	Senfter M.				Suffix	J xxxx
		Print	24.04.12	Nelson Gardens LFG			Wiring diagram	J N795 + M1 / 52
Modific.	Date	Name	Check	Pieschnik A.	DIR: J:\EPLAN4\VP\ANL\BEN\WXXX\N7XX\JN795.P	KW 12 - 2012	EPLAN 5	

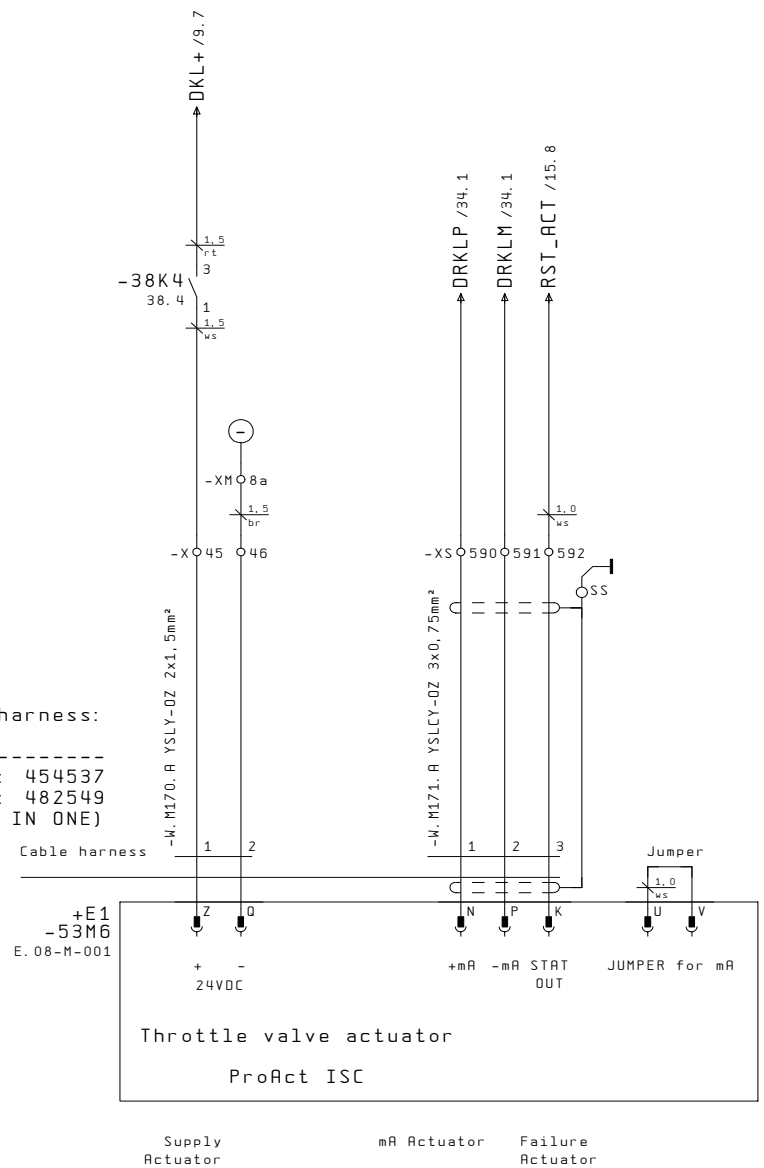

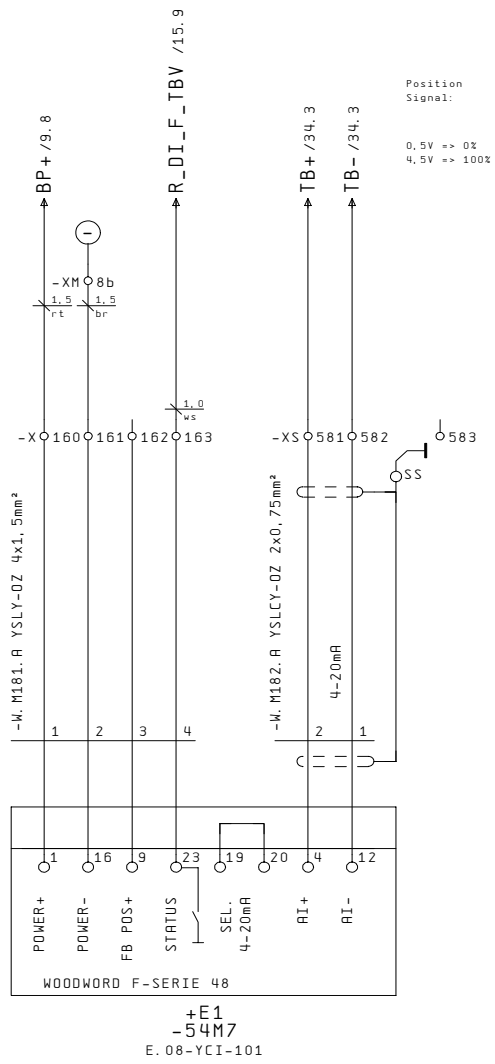

		Date	18.01.06	4 x JGS 320 GS-L.L	 Jenbacher gas engines	Butterfly flap	SD-Nr. Project	8662	
		Desig.	Senfter M.	Nelson Gardens LFG			Suffix	J xxxx	
Modific.	Date	Name	Check	Pieschnik A.			DIR: J:\EPLAN4\VP\ANL\BEN\WXXX\N7XX\JN795.P	KW 12 - 2012	EPLAN 5

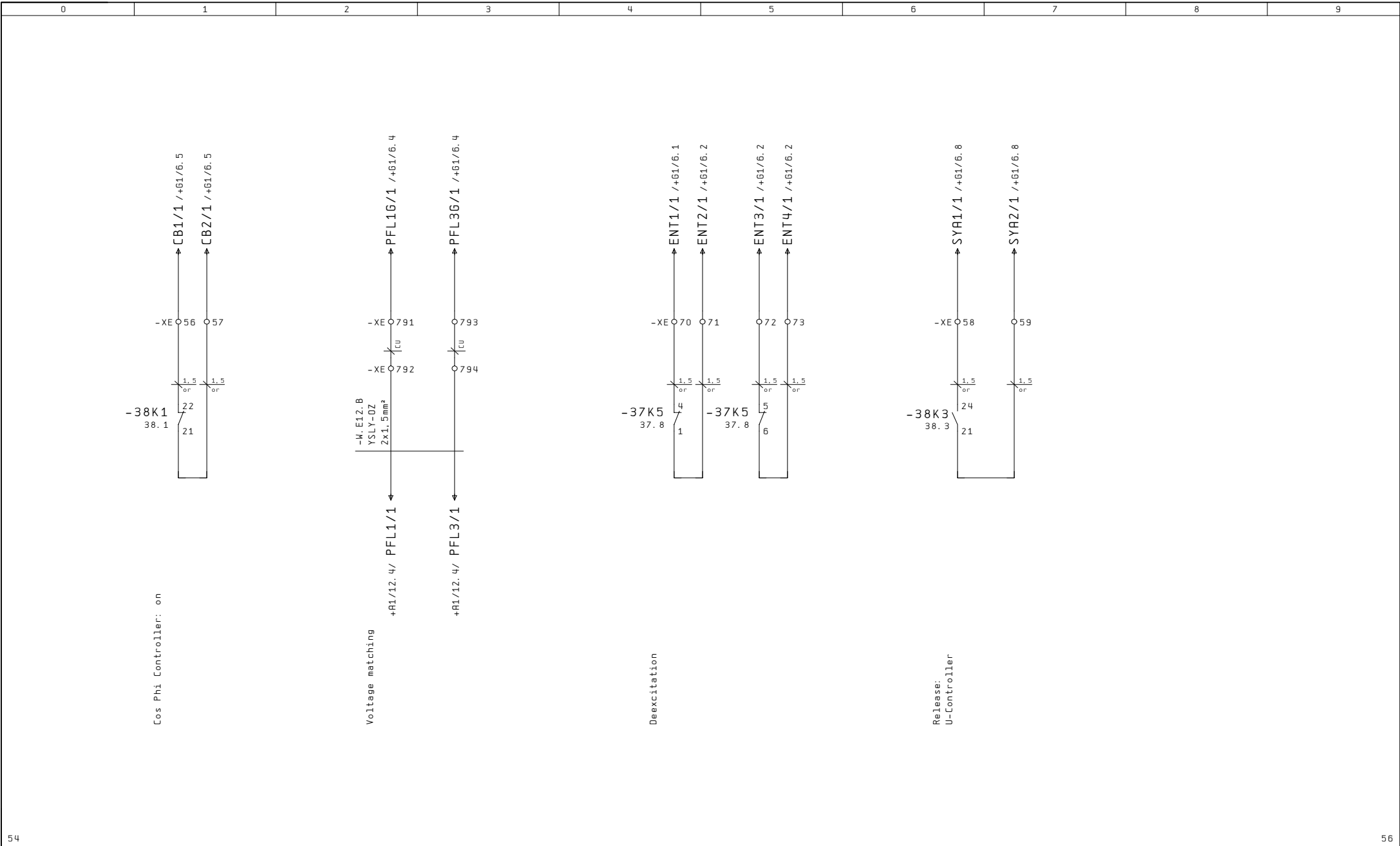

Turbo bypass valve 1

		Date	18.01.06	4 x JGS 320 GS-L.L	 Jenbacher gas engines	Turbo bypass valves	SD-Nr. Project	8662
		Desig.	Senfter M.	Nelson Gardens LFG		Suffix	J xxxx	
		Print	24.04.12			Wiring diagram	J N795 + M1 / 54	
Modific.	Date	Name	Check	Pieschnik A.	DIR: J:\EPLAN4\VP\ANL\GEN\WXXX\N7XX\JN795.P	KW 12 - 2012	EPLAN 5	



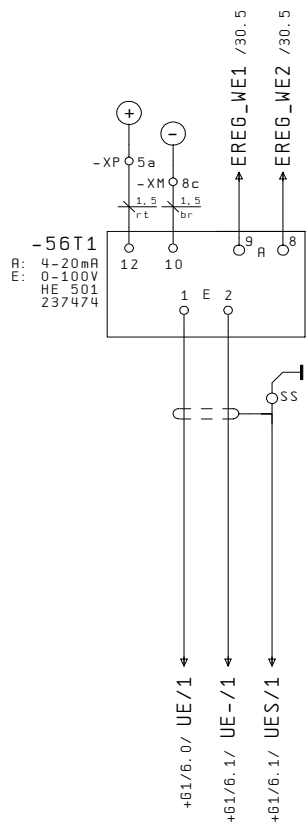

		Date	18.01.06	4 x JGS 320 GS-L.L	 Jenbacher gas engines	Signals Generator <--> +M	SD-Nr. Project	8662
		Desig.	Senfter M.	Nelson Gardens LFG			Suffix	J xxxx
		Print	24.04.12				Wiring diagram	J N795 + M1 / 55
Modific.	Date	Name	Check	Pieschnik A.	DIR: J:\EPLAN4\VP\ANL\BEN\WXXX\N7XX\JN795.P	KW 12 - 2012	EPLAN 5	

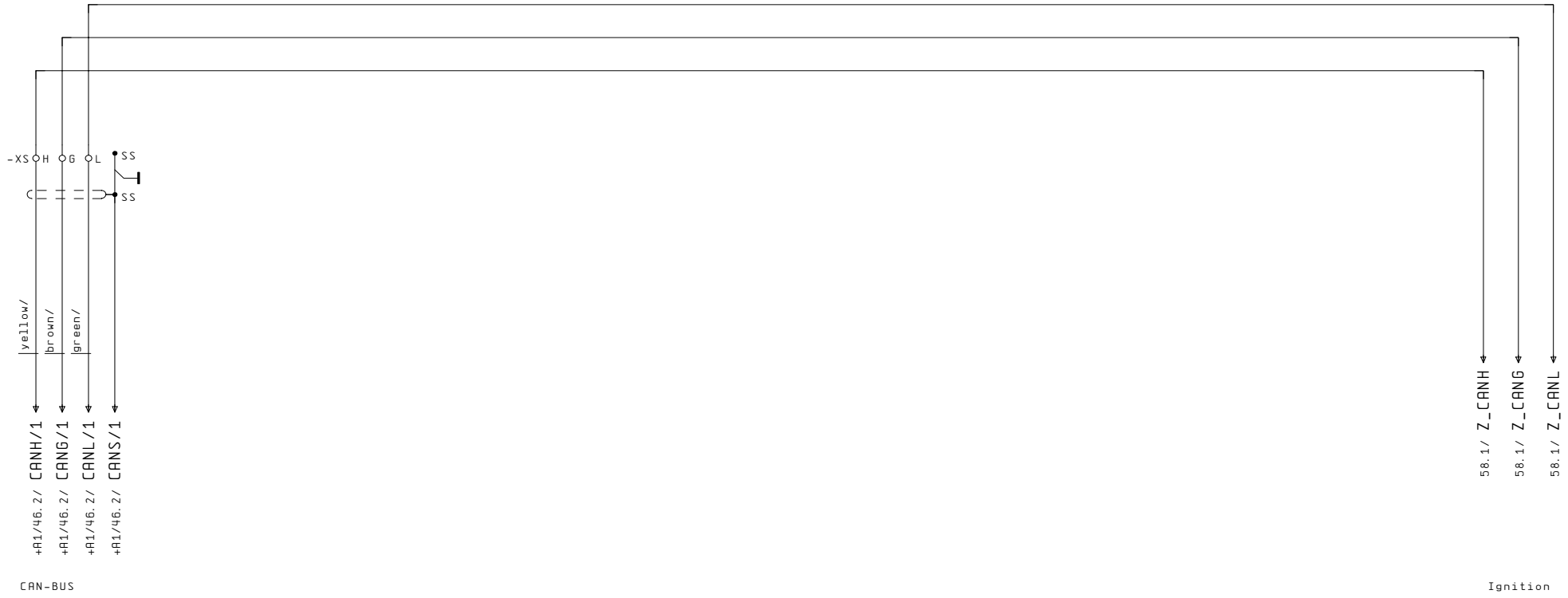

Excitation voltage Generator

		Date	18.01.06	4 x JGS 320 GS-L.L	 Jenbacher gas engines	Signals Generator <--> +M	SD-Nr. Project	8662
		Desig.	Senfter M.	Nelson Gardens LFG		Suffix	J xxxx	
		Print	24.04.12			Wiring diagram	J N795 + M1 / 56	
Modific.	Date	Name	Check	Pieschnik A.	DIR: J:\EPLAN4\VP\ANL\BEN\WXXX\N7XX\JN795.P	KW 12 - 2012	EPLAN 5	



		Date	18.01.06	4 x JGS 320 GS-L.L		 Jenbacher gas engines	CAN Bus		SD-Nr.	8662
		Desig.	Senfter M.	Nelson Gardens LFG			Suffix	J xxxx		
		Print	24.04.12				Wiring diagram	J N795 + M1 / 57		
Modific.	Date	Name	Check	Pieschnik A.	DIR: J:\EPLAN4\P\ANL\BEN\WXXX\N7XX\JN795.P	KW 12 - 2012	EPLAN 5			

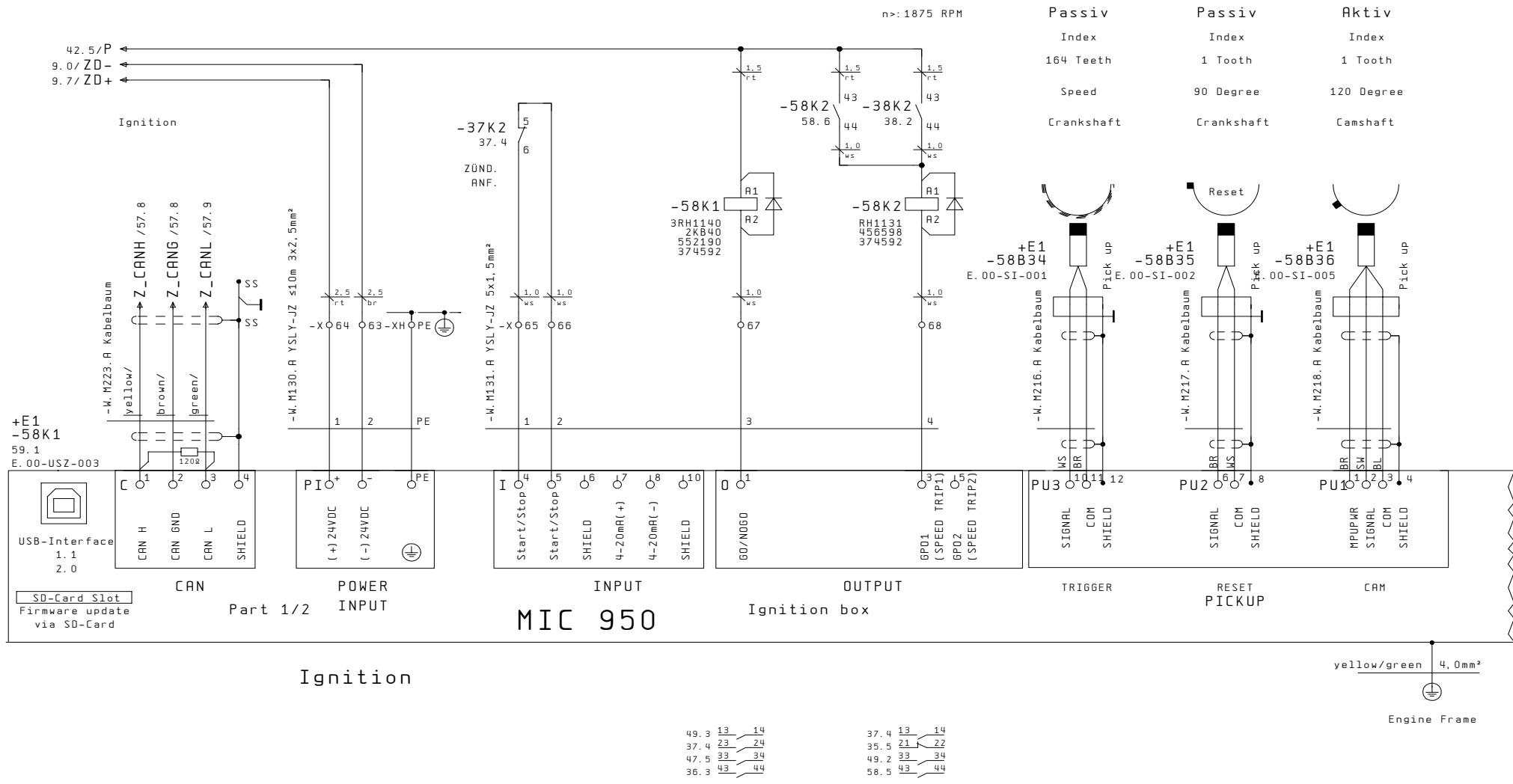

Date	18.01.06	4 x JGS 320 GS-L.L	Jenbacher gas engines	Ignition system MIC950	SD-Nr.-Project	8662	
Desig.	Senfter M.	Nelson Gardens LFG			Suffix	J xxxx	
Print	24.04.12				Wiring diagram	J N795 + M1 / 58	
Modific.	Date	Name	Check	Pieschnik A.	DIR: J:\EPLAN4\VP\ANLAGEN\WXXX\N7XX\JN795.P	KW 12 - 2012	EPLAN 5

+E1
-58K1
58.0

Part 2/2

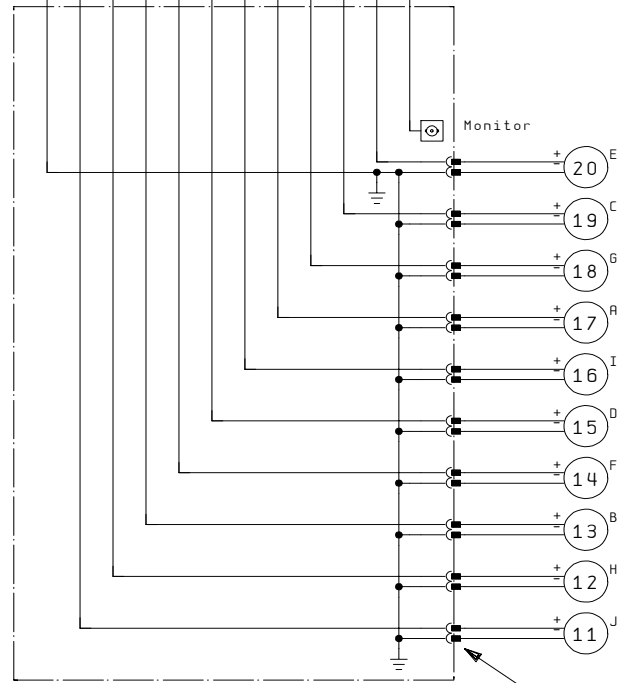
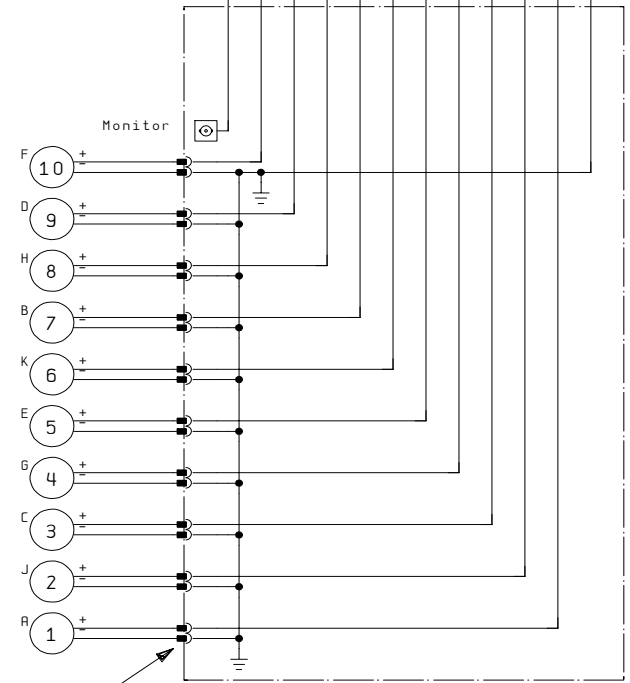
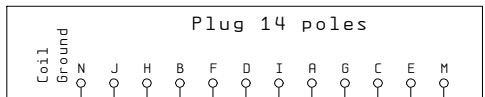
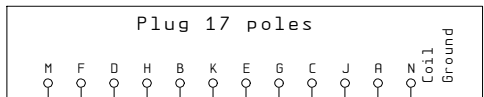

Plug at: IC / AIC

Firing order: 1-17-7-13-3-19-9-15-5-20-10-14-4-18-8-12-2-16-6-11

Plug at: IC / AIC

		Date	18.01.06	4 x JGS 320 GS-L.L		Jenbacher gas engines	Ignition coils		SD-Nr. Project	8662
		Desig.	Senfter M.	Nelson Gardens LFG			Suffix	J xxxx		
		Print	24.04.12	DIR: J:\EPLAN\4P\ANL\GEN\WXXX\N7XX\JN795.P			Wiring diagram	J N795 + M1 / 59		
Modific.	Date	Name	Check	Pieschnik A.	KW 12 - 2012	EPLAN 5				



Spare

Spare

			Date	18.01.06	4 x JGS 320 GS-L.L	 Jenbacher gas engines	Spare	SD-Nr. Project	8662
			Desig.	Senfter M.	Nelson Gardens LFG			Suffix	J xxxx
			Print	24.04.12				Wiring diagram	J N795 + M1 / 60
Modific.	Date	Name	Check	Pieschnik R.	DIR: J:\EPLAN4\VP\ANL\BEN\WXXX\N7XX\JN795.P	KW 12 - 2012	EPLAN 5		

0	1	2	3	4	5	6	7	8	9
Terminal strip	+M1-X								
Jumpers									
Terminal									

60

62

Date	18.01.06	4 x JGS 320 GS-L.L		Jenbacher gas engines	Terminals general +M1	SD-Nr. Project	8662
Design	Senfter M.	Nelson Gardens LFG				Suffix	
Print	24.04.12					Wiring diagram	J N795 + M1 / 61
Modific.	Date	Name	Check	Pieschnik A.	DIR: J:\EPLAN4\VP\ANL\GEN\WXXX\N7XX\JN795.P	EPLAN 5	

0	1	2	3	4	5	6	7	8	9															
Terminal strip	+M1-X																							
Jumpers	I	=	0	=	Vibration Alarm	=	Oil differential pressure high	=	Air-gas mixer P1	=	=	=	Gassafety device 1	=	=	=	Gas pressure low Gas train 1	=	Turbo bypass valve 1	=	=	=	Failure: Generator Controller	=
Terminal	65	66	67	68	86	87	88	89	92	93	94	95	100	101	102	103	104	105	160	161	162	163	176	177
<p>Wiring diagram details:</p> <ul style="list-style-type: none"> Terminal 65: +M1-M. M113. A YSLY-JZ 5x1.5mm² (I) Terminal 66: +M1-M. M112. A YSLY-OZ 2x1.5mm² (Vibration Alarm) Terminal 67: +M1-M. M114. A YSLY-OZ 2x1.5mm² (Oil differential pressure high) Terminal 68: +M1-M. M149. A YSLY-JZ 5x0.75mm² (Air-gas mixer P1) Terminal 86: +M1-M. E25. A YSLY-JZ 4x1.5mm² (Gassafety device 1) Terminal 87: +M1-M. E20. A YSLY-OZ 2x1.5mm² (Gas pressure low Gas train 1) Terminal 88: +M1-M. M181. A YSLY-OZ 4x1.5mm² (Turbo bypass valve 1) Terminal 176: +G1-M. M194. A YSLY-OZ 2x1.5mm² (Failure) 																								

61	Date	18.01.06	4 x JGS 320 GS-L.L
	Desig.	Senfter M.	
	Print	24.04.12	Nelson Gardens LFG
Modific.	Date	Name	Check Pieschnik A. DIR: J:\EPLAN4\VP\ANL\BEN\WXXX\N7XX\JN795.P

Jenbacher
gas engines

Terminals general +M1

SD-Nr. Project	8662
Suffix	
Wiring diagram	J N795 +M1 / 62

0	1	2	3	4	5	6	7	8	9								
Terminal strip	+M1-XM																
Device / Function	Charging unit	Module control panel	Control	Prelubrication oil pump Cool down oilpump	Resistor - Digital Input	Supply PLC	=	Oil pressure	Jacket water pressure	Supercharge pressure	Mixer position	Knocking detector 1	Knocking detector 2	Butterfly flap	=	Turbo bypass valve	=
Page	/9.0	/9.1	/9.3	/12.5	/15.0	/24.4	/24.6	/29.1	/29.3	/29.5	/29.7	/30.1	/30.3	/34.1	/34.2	/34.3	/34.4
Jumpers	●																
Terminal	1a	1b	1c	1d	2a	2b	2c	2d	3a	3b	3c	3d	4a	4b	4c	4d	5a

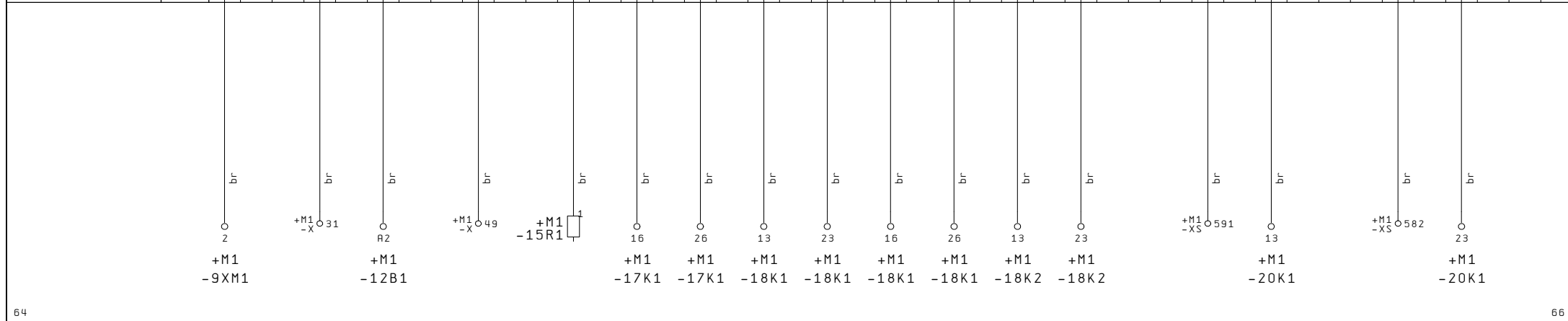

64		66	
Modific.	Date	Name	Check
		Pieschnik A.	
Date		18.01.06	
Design		Senfter M.	
Print		24.04.12	
Name		4 x JGS 320 GS-L.L	
Project		Nelson Gardens LFG	
Suffix		DIR: J:\EPLAN4\VP\ANL\BEN\WXXX\N7XX\N795.P	
Wiring diagram		J N795 +M1 / 65	



Jenbacher gas engines

Terminals Base - 0VDC

SD-Nr. Project 8662
 Suffix
 Wiring diagram J N795 +M1 / 65

0	1	2	3	4	5	6	7	8	9
Terminal strip +M1-XM									
Jumpers									
Terminal									
<div style="display: flex; justify-content: space-between;"> <div style="width: 15%;"> <p>Device / Function</p> <p>Cos-Phi Signal</p> <p>=</p> <p>=</p> <p>Prelubrication Cool down oilpump</p> <p>Oil valve</p> <p>Start relay</p> <p>Gas valves open Gas train 1</p> <p>Emergency stop Relay</p> <p>Gas safety device 1</p> <p>=</p> <p>Gas valve 1 Gas train 1</p> <p>Supply Actuator</p> <p>Turbo bypass valve 1</p> <p>Excitation voltage Generator</p> <p>Spare</p> <p>=</p> <p>=</p> <p>=</p> </div> <div style="width: 15%;"> <p>Page</p> <p>/34.6</p> <p>/34.6</p> <p>/34.8</p> <p>/37.4</p> <p>/42.1</p> <p>/47.1</p> <p>/47.5</p> <p>/50.1</p> <p>/51.1</p> <p>/51.2</p> <p>/52.2</p> <p>/53.6</p> <p>/54.1</p> <p>/56.1</p> <p>/60.5</p> <p>/60.5</p> <p>/60.5</p> <p>/60.5</p> </div> <div style="width: 70%;"> </div> </div>									

65

67

Date		18.01.06		4 x JGS 320 GS-L.L		Jenbacher gas engines		SD-Nr. Project		8662			
Design		Senfter M.		Nelson Gardens LFG				Terminals Base - 0VDC		Suffix			
Print		24.04.12								Wiring diagram		J N795 + M1 / 66	
Modific.	Date	Name	Check	Pieschnik A.		DIR: J:\EPLAN4\VP\ANL\BEN\WXXX\N7XX\JN795.P		EPLAN 5					

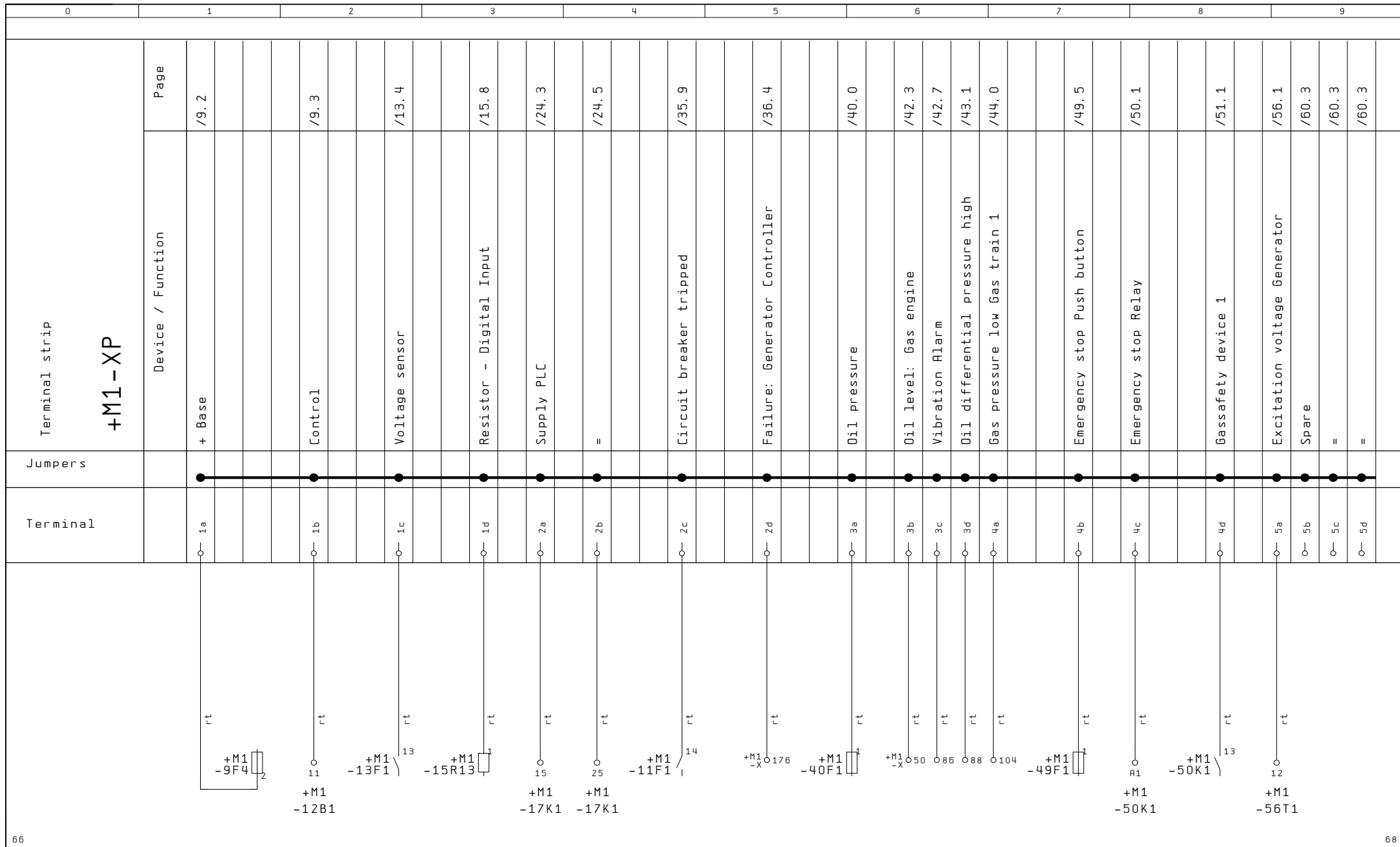

Modific.	Date	Name	Check	Pieschnik A.	DIR: J:\EPLAN4\VP\ANL\GEN\WXXX\N7XX\JN795.P	 Jenbacher gas engines	Terminals Base +24VDC	SD-Nr. Project	8662
								Suffix	
								Wiring diagram	J N795 +M1 / 67

0	1	2	3	4	5	6	7	8	9
Terminal strip +M1-XP	Page	/60. 3							
	Device / Function	Spare							
		=							
		=							
=									
Jumpers									
Terminal	○- 6a	○- 6b	○- 6c	○- 6d					

		Date	18.01.06	4 x JGS 320 GS-L.L	Jenbacher gas engines	Terminals	SD-Nr.	8662
		Desig.	Senfter M.	Nelson Gardens LFG		Base +24VDC	Project	
		Print	24.04.12				Suffix	
Modific.	Date	Name	Check	Pieschnik R.	DIR: J:\EPLAN4\VP\ANL\GEN\WXXX\N7XX\JN795.P		Wiring diagram	J N795 + M1 / 68

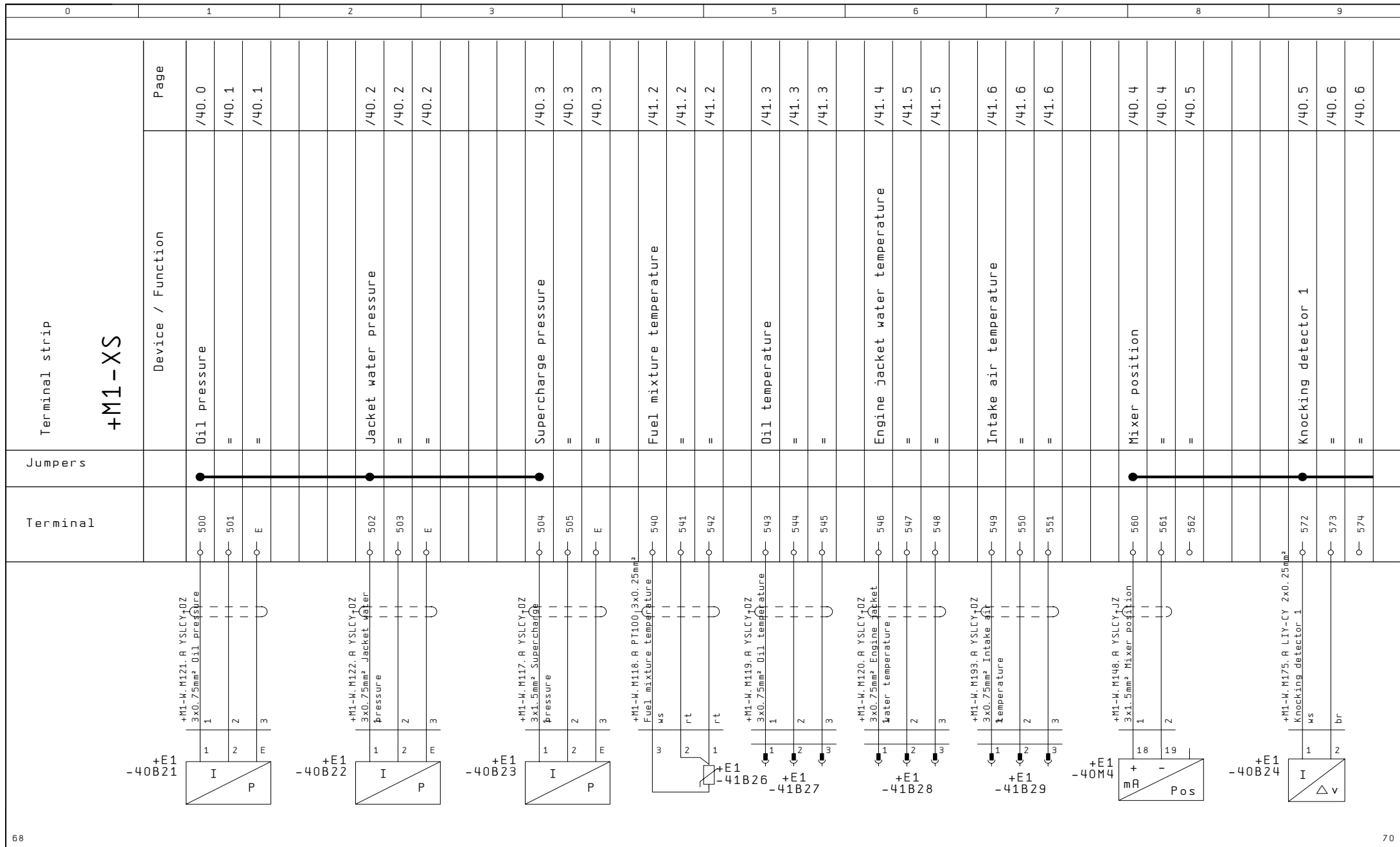

Date	18.01.06	4 x JGS 320 GS-L.L			
Desig.	Senfter M.				
Print	24.04.12				
Modific.	Date	Name	Check	Pieschnik A.	DIR: J:\EPLAN\4VP\ANL\BEN\WXXX\N7XX\JN795.P

Jenbacher
gas engines

EPLAN 5

Terminals	Shielded cable +M1
-----------	--------------------

SD-Nr. Project	8662
Suffix	
Wiring diagram	J N795 +M1 / 69

0	1	2	3	4	5	6	7	8	9
Terminal strip +M1-XS	Page								
	Device / Function	Cos-Phi-V-Signal Cos-Phi Signal							
Jumpers									
Terminal	0- 686 0- 687								

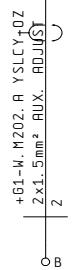

70

+R1/1

Modific.	Date	Name	Check	Pieschnik R.	DIR: J:\EPLAN4\PROJEKTE\N795\N795.P	 Jenbacher gas engines	Terminals Shielded cable +M1	SD-Nr. Project	8662
								Suffix	
								Wiring diagram	J N795 + M1 / 71

4 x JGS 320 GS-L.L
Nelson Gardens LFG

EPLAN 5

Module control panel +A1

Parameters for the operation
of GE Jenbacher Engines
acc. TI.Nr.: 1100-0110

Modifications of Design
reserved.

All Cables between the
Switchboards and the Engine
have to be in flexible mode.

Protection against electric shocks hazard
earthing, equipotential bonding, has to be
provided by the Customer at installation
according to local Standards !
At staes of delivery the engine
is prepared for the protection by
automatic disconnection of supply
in TN-Systems according to
HD 60364-4-41 / IEC 60364-4-41.

No.

The Numbers in the circles are in
Relation with the Numbers in the
Interface-List J N795

This Wiring Diagram is designed with
a CAE-System.
Modifications will be occupied by
GE Jenbacher

+M1/71

2

a			Date	18.01.06	4 x JGS 320 GS-L.L	 Jenbacher gas engines	Module control panel +A1	SD-Nr. Project	8662
			Desig.	Senfter M.	Nelson Gardens LFG			Suffix	J xxxx
			Print	24.04.12				Wiring diagram	J N795 +A1 / 1
Modific.	Date	Name	Check	Pieschnik R.	DIR: J:\EPLAN4\VP\ANL\BEN\WXXX\N7XX\JN795.P	KW 12 - 2012	EPLAN 5		

Diagram index

Page	Denomination	Modifications	Page	Denomination	Modifications
+A1/1	Module control panel +A1	a	+A1/14	Generator: [V] / [A]	
+A1/2	Diagram index		+A1/15	Selector switch	
+A1/2.1	Diagram index		+A1/16	Earthing/Grounding Connection A	
+A1/2.2	Diagram index		+A1/17	Earthing/Grounding Connection B	
+A1/3	Technical information		+A1/18	Earthing/Grounding Connection C	
+A1/4	type plate		+A1/19	Earthing/Grounding Connection D	
+A1/5	Wiring colours in panel		+A1/20	Earthing/Grounding	
+A1/6	Over view Terminal strips		+A1/21	Resistors	
+A1/7	caution label		+A1/22	Over view modules	
+A1/8	Module control panel		+A1/23	Slot address Over view	
+A1/9	Panel Roof / 1000		+A1/24	Slot address Over view	
+A1/10	Door cut out +A/ new		+A1/25	Slot address Over view	
+A1/11	Distribution 24VDC		+A1/26	Slot address Over view	
+A1/12	Voltage selection		+A1/27	Slot address Over view	
+A1/13	Mains monitoring device		+A1/28	BUS-RECEIVER	

1

2.1

		Date	18.01.06	4 x JGS 320 GS-L.L		 Jenbacher gas engines	Diagram index		SD-Nr. Project	8662
		Desig.	Senfter M.	Nelson Gardens LFG			Suffix	J xxxx		
		Print	24.04.12				Wiring diagram	J N795 +A1 / 2		
Modific.	Date	Name	Check	Pieschnik A.	DIR: J:\EPLAN4\VP\ANL\GEN\WXXX\N7XX\JN795.P	KW 12 - 2012	EPLAN 5			

Diagram index

Page	Denomination	Modifications	Page	Denomination	Modifications
+A1/29	Multi measuring and monitoring device		+A1/44	SWITCH	
+A1/30	Multi measuring and monitoring device		+A1/45	MODBUS RTU	
+A1/31	Multi measuring and monitoring device		+A1/46	CAN-Bus	
+A1/32	Digital Inputs		+A1/47	Temperature sensor	
+A1/33	Digital Inputs		+A1/48	Control Auxiliaries	
+A1/34	Digital Inputs	a	+A1/49	Cooling circuit / Fuel mixture circuit	
+A1/35	Digital Inputs		+A1/50	Control Generator circuit breaker	
+A1/36	Digital Outputs		+A1/51	Control Generator circuit breaker	
+A1/37	Digital Outputs		+A1/52	Emergency stop	
+A1/38	Digital Outputs		+A1/53	Interfaces: Jenbacher --> Customer	
+A1/39	Analog Inputs		+A1/54	Report signals	
+A1/40	Analog Inputs		+A1/55	Interfaces: Customer --> Jenbacher	
+A1/41	Analog Outputs		+A1/56	Interfaces: Customer --> Jenbacher	a
+A1/42	BUS-TRANSMITTER		+A1/57	Interfaces: Customer --> Jenbacher	
+A1/43	Powerpanel XT3		+A1/58	Interfaces Generator circuit breaker	



Date		18.01.06		4 x JGS 320 GS-L.L		 Jenbacher gas engines	Diagram index		SD-Nr.	8662	
Desig.		Senfter M.		Nelson Gardens LFG			Suffix	J xxxx			
Print		24.04.12					Wiring diagram	J N795 +A1 / 2.1			
Modific.	Date	Name	Check	Pieschnik A.		DIR: J:\EPLAN4\PA\ANLAGEN\XXXX\N7XX\JN795.P	KW 12 - 2012		EPLAN 5		

Diagram index

Page	Denomination	Modifications	Page	Denomination	Modifications
+A1/59	Interfaces: Customer --> Jenbacher				
+A1/60	Spare				
+A1/61	Terminals general +A1				
+A1/62	Terminals general +A1				
+A1/63	Terminals general +A1				
+A1/64	Terminals Commands: GCB/MCB				
+A1/65	Terminals External Voltage +A1				
+A1/66	Terminals External Voltage +A1				
+A1/67	Terminals Auxiliaries +A1				
+A1/68	Terminals Base - 0VDC				
+A1/69	Terminals Base - 0VDC				
+A1/70	Terminals Base +24VDC				
+A1/71	Terminals Base +24VDC				
+A1/72	Terminals Shielded cable +A1				

2.1

3

		Date	18.01.06	4 x JGS 320 GS-L.L		 Jenbacher gas engines	Diagram index	SD-Nr.	8662
		Desig.	Senfter M.	Nelson Gardens LFG				Suffix	J xxxx
		Print	24.04.12					Wiring diagram	J N795 +A1 / 2.2
Modific.	Date	Name	Check	Pieschnik A.	DIR: J:\EPLAN4\P\ANL\BEN\XXXX\N7XX\JN795.P	KW 12 - 2012	EPLAN 5		

Insulation	Ue= 480V, Ui= 480V		
Net form:	TN-S		
Protection:	IP42: Indoor installation (for installation in control room)		
Auxiliary power circuits	Vaux = 24VDC		
ambient temperature:	+5°C - +40°C	up positioned	<2000m
Relative humidity:	70%	Degree of fouling:	3
EMC Immunity:	Environment A	EMC Emission:	Environment B
Static frequency oscillation width:	+4 /- 6%	Static voltage difference:	+/- 10%
Dynamic frequency difference:	+18 / -25%	Frequency control settling time:	10sec
Dynamic voltage difference:	+35 / -25%	Voltage control settling time:	10sec
Weight:	apr. 250 kg		

2.2

4

		Date	18.01.06	4 x JGS 320 GS-L.L	 Jenbacher gas engines	Technical information	SD-Nr. Project	8662
		Desig.	Senfter M.	Nelson Gardens LFG			Suffix	J xxxx
		Print	24.04.12				Wiring diagram	J N795 + R1 / 3
Modific.	Date	Name	Check	Pieschnik A.	DIR: J:\EPLAN4\P\ANL\BEN\WXXX\N7XX\JN795.P	KW 12 - 2012	EPLAN 5	

 **Jenbacher**
gas engines

GE Jenbacher GmbH & Co. OG
Achenseestraße 1-3
A-6200 Jenbach (Austria)



Project	Job	8662	...
Wiring diagram		J N795 + A1	
Serial No.		1058636	
Year of manufacture		2012	
Standard		IEC 60439-1	

 **Jenbacher**
gas engines

GE Jenbacher GmbH & Co. OG
Achenseestraße 1-3
A-6200 Jenbach (Austria)



Project	Job	8662	...
Wiring diagram		J N795 + A2	
Serial No.		1058624	
Year of manufacture		2012	
Standard		IEC 60439-1	

 **Jenbacher**
gas engines

GE Jenbacher GmbH & Co. OG
Achenseestraße 1-3
A-6200 Jenbach (Austria)



Project	Job	8662	...
Wiring diagram		J N795 + A3	
Serial No.		1058634	
Year of manufacture		2012	
Standard		IEC 60439-1	

 **Jenbacher**
gas engines

GE Jenbacher GmbH & Co. OG
Achenseestraße 1-3
A-6200 Jenbach (Austria)



Project	Job	8662	...
Wiring diagram		J N795 + A4	
Serial No.		1058621	
Year of manufacture		2012	
Standard		IEC 60439-1	

		Date	18.01.06	4 x JGS 320 GS-L.L	 Jenbacher gas engines	type plate	SD-Nr. Project	8662
		Desig.	Senfter M.	Nelson Gardens LFG			Suffix	J xxxx
		Print	24.04.12				Wiring diagram	J N795 + A1 / 4
Modific.	Date	Name	Check	Pieschnik A.	DIR: J:\EPLAN4\VP\ANLAGEN\WXXX\N7XX\JN795.P	KW 12 - 2012	EPLAN 5	

Wiring colours in panel

AC :

Outside wire before (or) orange
 Auxiliaries-supply
 disconnecting device : [L1 / L2 / L3]



Outside wire after (sw) black
 Auxiliaries-supply
 disconnecting device : [L1 / L2 / L3]

External Voltage : (or) orange
 (U/I - Measurement)

Protective wire [PE] : (gegn) green/yellow

N-Conductor [N] : (hbl) light blue

Function ground : (tr) transparent

24V AC : (gr) (grey)

Standard Type: H05V-K (≤ 1,0mm²)
 H07V-K (≥ 1,5mm²)

Wiring colours in panel:

DC :

Plus : (rt) red

Minus : (br) brown

Control : (ws) white

Thermo compensation cable (gn) + green
 (ws) - white

External Voltage : (or) orange
 (Voltage free contacts)

Standard Type: H05V-K (≤ 1,0mm²)
 H07V-K (≥ 1,5mm²)

		Date	18.01.06	4 x JGS 320 GS-L.L	 Jenbacher gas engines	Wiring colours in panel	SD-Nr. Project	8662
		Desig.	Senfter M.	Nelson Gardens LFG			Suffix	J xxxx
		Print	24.04.12				Wiring diagram	J N795 + R1 / 5
Modific.	Date	Name	Check	Pieschnik A.	DIR: J:\EPLAN4\VP\ANL\BEN\WXXX\N7XX\JN795.P	KW 12 - 2012	EPLAN 5	

Over view Terminal strips

<p>- X: -X=Terminals general +A1</p> <p>- XH: -XH=Terminals Auxiliaries +A1</p> <p>- XH1: -XH1=Terminals Sockets + Light</p> <p>- XS: -XS=Terminals Shielded cable +A1</p> <p>- XP: -XP=Terminals Base +24VDC</p> <p>- XM: -XM=Terminals Base - 0VDC</p> <p>- XE: -XE=Terminals External Voltage +A1</p> <p>- XE1: -XE1=Terminals Supply Auxiliaries</p>	<p>- XCB: -XCB=Terminals Commands: GCB/MCB</p>
---	---

		Date	18.01.06	4 x JGS 320 GS-L.L	 Jenbacher gas engines	Over view Terminal strips	SD-Nr. Project	8662
		Desig.	Senfter M.	Nelson Gardens LFG			Suffix	J xxxx
		Print	24.04.12				Wiring diagram	J N795 + A1 / 6
Modific.	Date	Name	Check	Pieschnik A.	DIR: J:\EPLAN4\VP\ANL\BEN\XXXX\N7XX\JN795.P	KW 12 - 2012	EPLAN 5	

see TI-No 2300-0005

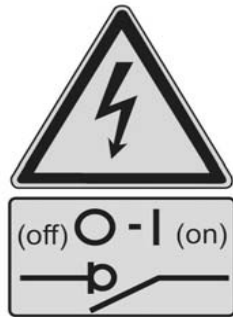

Dieses Warnschild in der Nähe der Netz-Trenneinrichtung bedeutet, dass nicht alle Stromkreise durch die Netz-Trenneinrichtung abgeschaltet werden. Die Kennzeichnung der nicht abgeschalteten "ausgenommenen Stromkreise" ist im Schaltplan beschrieben.



If you see this warning near the mains isolating device, this means that the mains isolating device does not switch off all electrical circuits. The 'except for' electrical circuits -i.e. the circuits that are not switched off- are shown in the circuit diagram.



		Date	18.01.06	4 x JGS 320 GS-L.L	 Jenbacher gas engines	caution label	SD-Nr. Project	8662
		Desig.	Senfter M.	Nelson Gardens LFG			Suffix	J xxxx
		Print	24.04.12				Wiring diagram	J N795 + R1 / 7
Modific.	Date	Name	Check	Pieschnik A.	DIR: J:\EPLAN4\VP\ANL\AGEN\WXXX\N7XX\JN795.P	KW 12 - 2012	EPLAN 5	

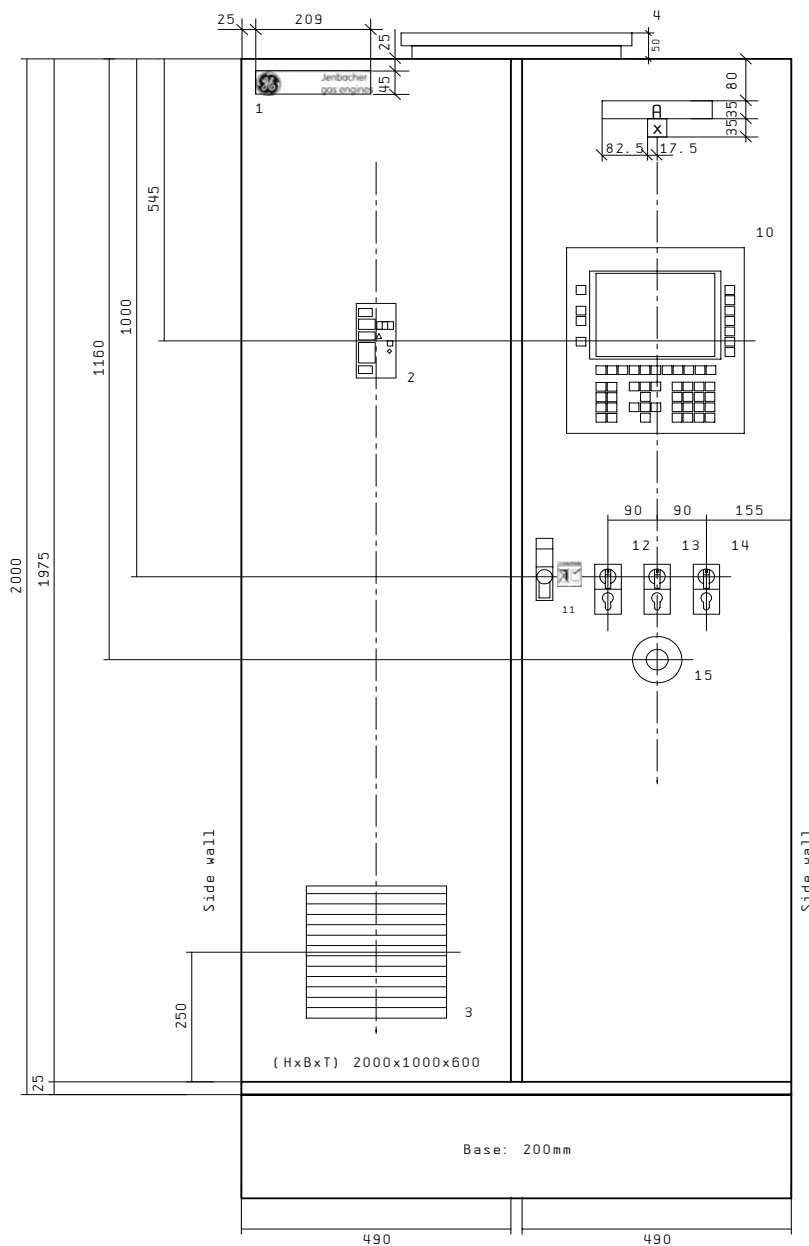

Positioning:

- 1 ... brand label
- A ... Module control panel
- 2 - 13B1 Mains monitoring device
- 3 - 11M1 Panel fan
- 4 ... Air outlet
- 10 - 42K1 DIANE XT3
- 11... caution label
- 12 - 15S1 Service selector switch
- 13 - 15S2 Demand selector switch
- 14 - 15S3 Synchronisation selector switch
- 15 - 51S1 Emergency stop

Cable entry at the bottom

Colour:
Panel RAL7035
Base RAL7022

Protection: IP42

labeling:
englisch

Protection internal:
IP 2x / IPxxB

Date	18.01.06	4 x JGS 320 GS-L.L
Desig.	Senfter M.	
Print	24.04.12	Nelson Gardens LFG
Modific.	Date	Name
		Check
		Pieschnik A.

DIR: J:\EPLAN4\VP\ANL\BEN\WXXX\N7XX\JN795.P



Jenbacher
gas engines

Module control panel

SO-Nr.	Project	8662
Suffix	J	xxxx
Wiring diagram	J N795 + A1	/ 8

Mains monitoring device
MRG..

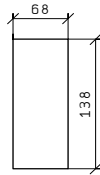

DIANE XT3

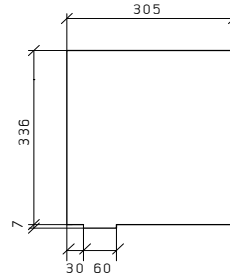

Fan

Switch to lock

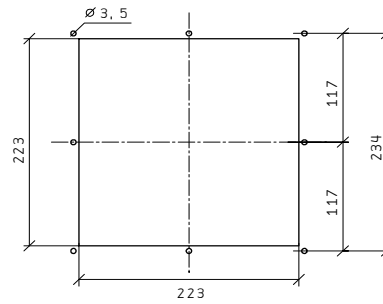
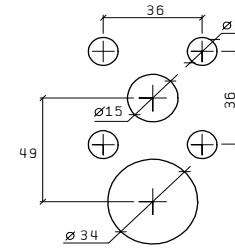

Emergency stop

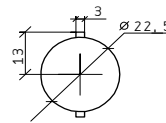

Supply disconnecting device

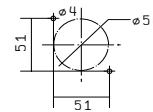

		Date	18.01.06	4 x JGS 320 GS-L.L	 Jenbacher gas engines	Door cut out +R/ new	SD-Nr. Project	8662
		Desig.	Senfter M.	Nelson Gardens LFG		Suffix	J xxxx	
		Print	24.04.12			Wiring diagram	J N795 +R1 / 10	
Modific.	Date	Name	Check	Pieschnik R.	DIR: J:\EPLAN4\P\ANL\BEN\WXXX\N7XX\JN795.P	KW 12 - 2012	EPLAN 5	

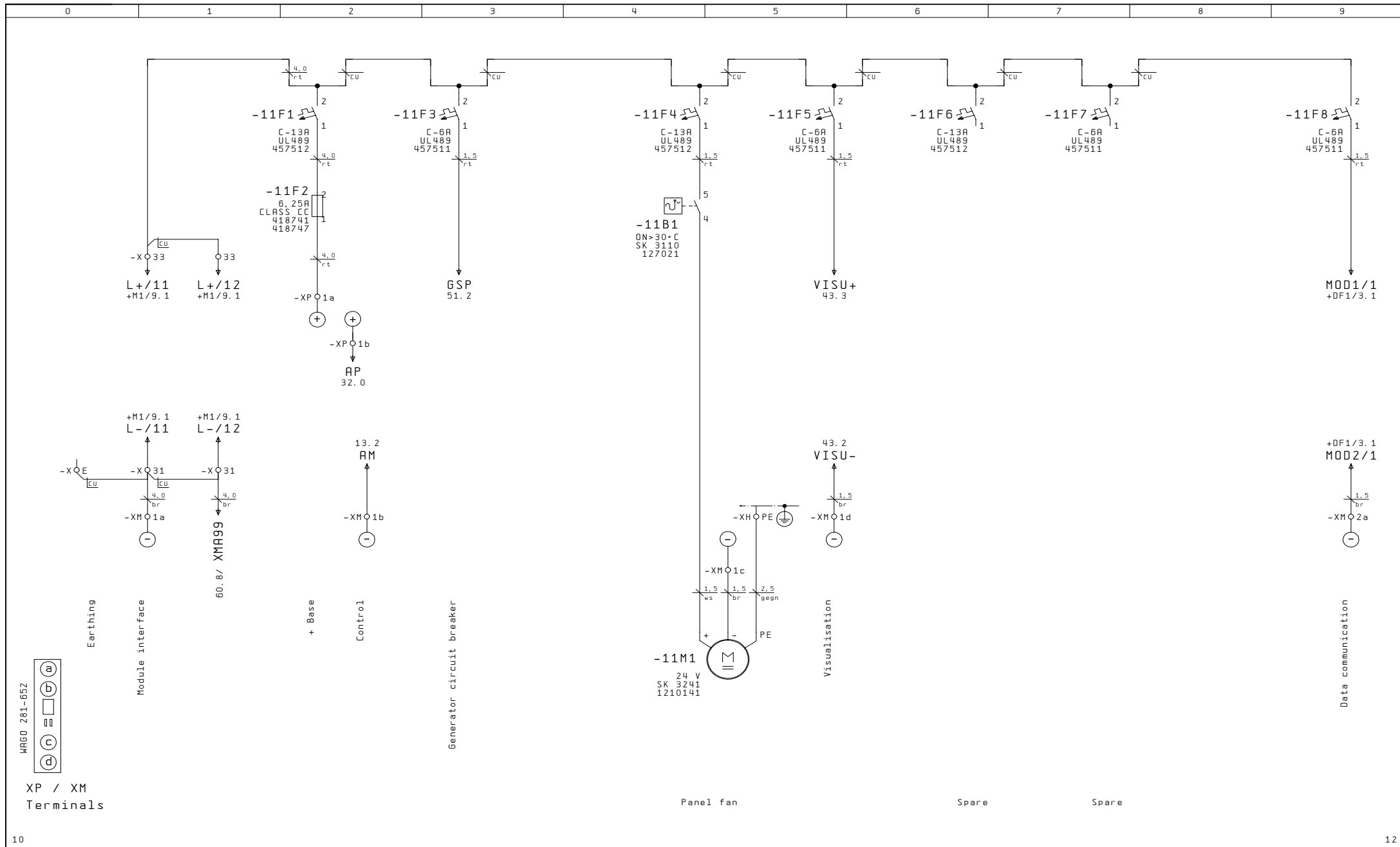

Date		18.01.06		4 x JGS 320 GS-L.L		 Jenbacher gas engines		Distribution 24VDC		SD-Nr. Project		8662	
Desig.		Senfter M.		Nelson Gardens LFG				Suffix		J xxxx			
Print		24.04.12		DIR: J:\EPLAN4\VP\ANLAGEN\WXXX\N7XX\JN795.P				Wiring diagram		J N795 + R1 / 11			
Modific.	Date	Name	Check	Pieschnik A.	KW 12 - 2012 EPLAN 5								

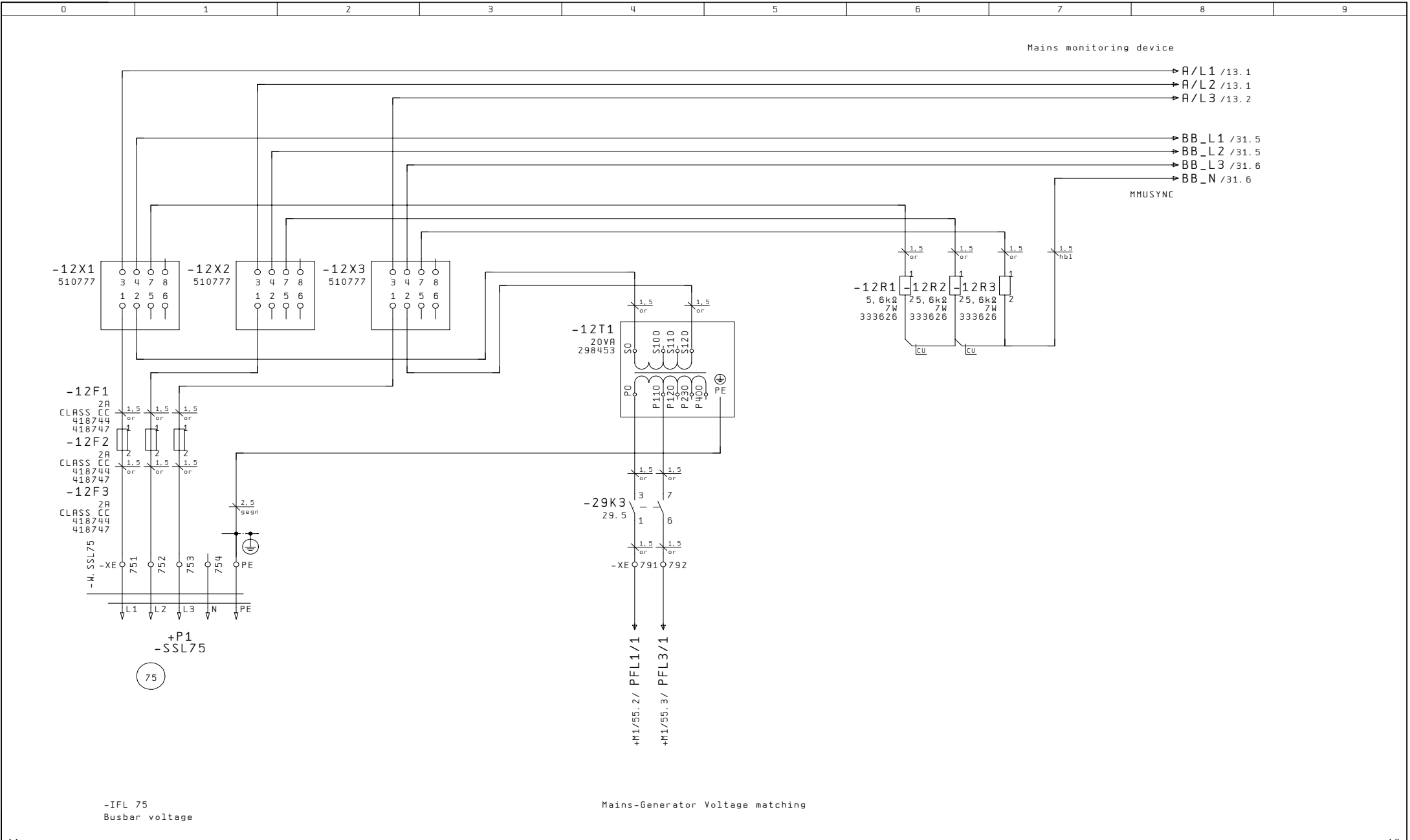

Date		18.01.06		4 x JGS 320 GS-L.L		Jenbacher gas engines	Voltage selection		SD-Nr. Project	8662	
Desig.		Senfter M.		Nelson Gardens LFG			Suffix	J xxxx			
Print		24.04.12					Wiring diagram	J N795 + R1 / 12			
Modific.	Date	Name	Check	Pieschnik A.	DIR: J:\EPLAN4\PLANLARGEN\WXXX\N7XX\JN795.P	KW 12 - 2012	EPLAN 5				

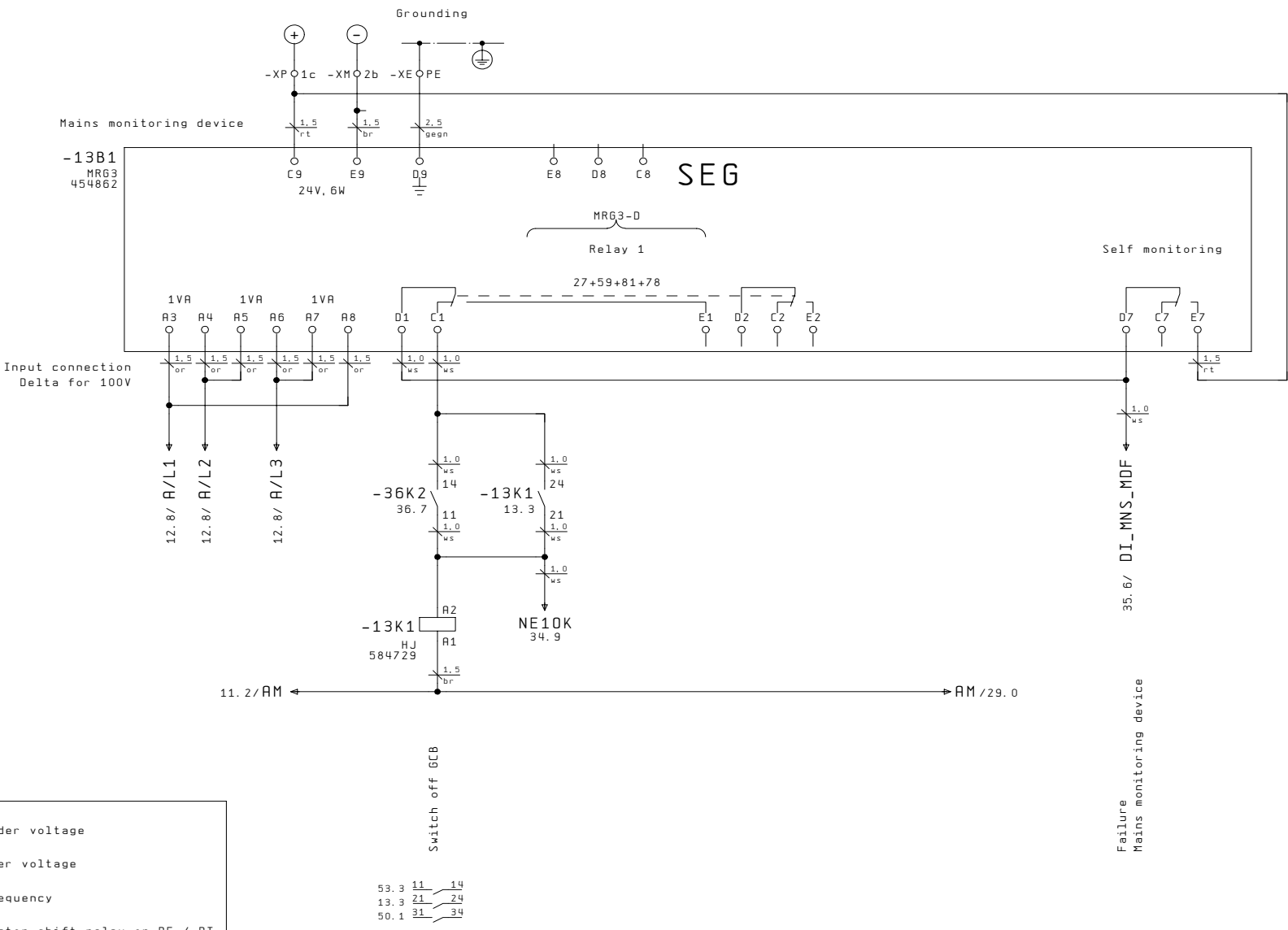

Un ... 120 V

Voltage

U< ... 90% Un
tU< ... 1 sec
U<< ... 80% Un
tU<< ... 0,2 sec
U> ... 110% Un
tU> ... 30 sec
U>> ... 115% Un
tU>> ... 0,2 sec

fn ... 60Hz

Frequency

f1 ... -1 Hz(fn)
tf1 ... 0,5 sec
f2 ... -1,5 Hz(fn)
tf2 ... 0,1 sec
f3 ... +1,5 Hz(fn)
tf3 ... 0,1 sec
tf ... 4 Cycle

Vector shift relay

Δθ ... 8°

Ansi Codes:

27	Under voltage
59	Over voltage
81	Frequency
78	Vector shift relay or DF / DT

53.3	11	14
13.3	21	24
50.1	31	34

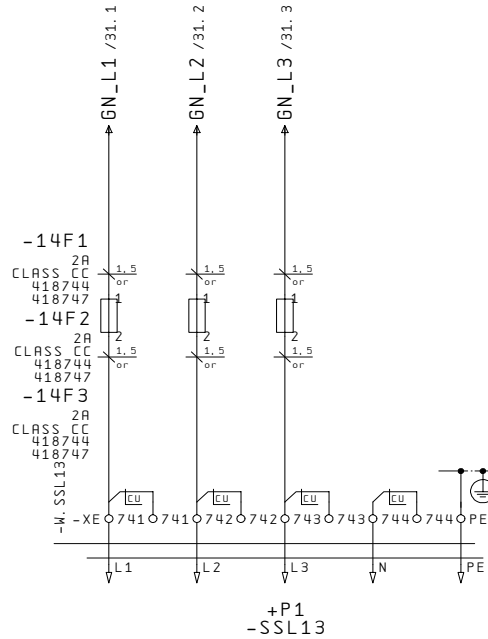
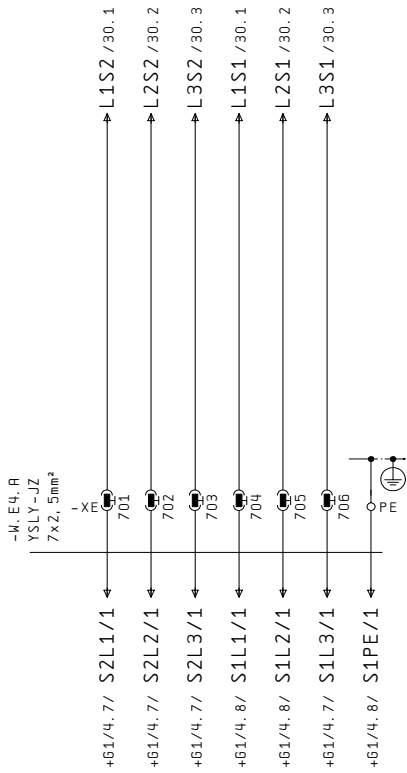

13

		Date	18.01.06	4 x JGS 320 GS-L.L	 Jenbacher gas engines	Generator: [V] / [A]	SD-Nr. Project	8662
		Desig.	Senfter M.	Nelson Gardens LFG		Suffix	J xxxx	
		Print	24.04.12			Wiring diagram	J N795 + R1 / 14	
Modific.	Date	Name	Check	Pieschnik A.	DIR: J:\EPLAN4\VP\ANL\BEN\WXXX\N7XX\JN795.P	KW 12 - 2012	EPLAN 5	

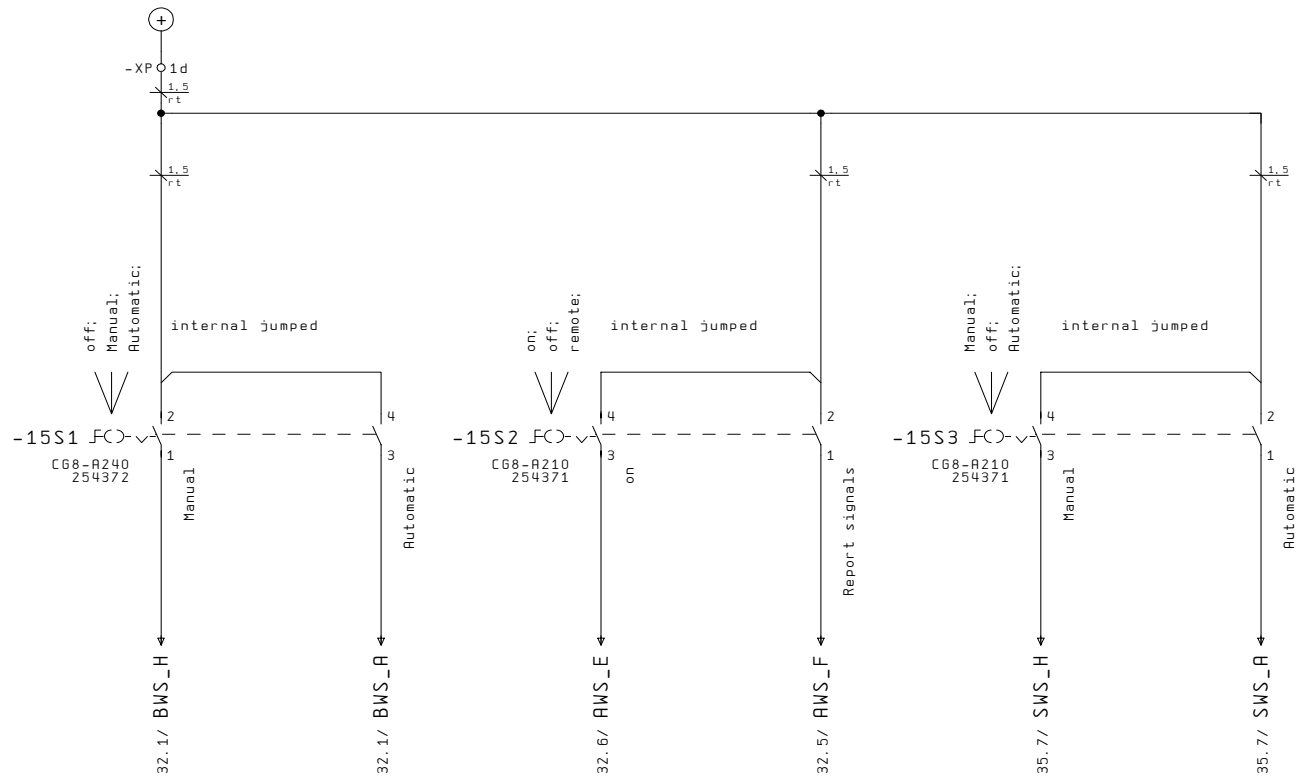

Service selector switch Manual

Service selector switch Automatic

Demand Selector switch on

Demand Selector switch remote

SY-Selector switch Manual

SY-Selector switch Automatic

		Date	18.01.06	4 x JGS 320 GS-L.L	 Jenbacher gas engines	SD-Nr.-Project	8662
		Desig.	Senfter M.	Nelson Gardens LFG		Suffix	J xxxx
		Print	24.04.12			Wiring diagram	J N795 + R1 / 15
Modific.	Date	Name	Check	Pieschnik A.	DIR: J:\EPLAN4\VP\ANL\BEN\WXXX\N7XX\JN795.P	KW 12 - 2012	EPLAN 5

Grounding Connection

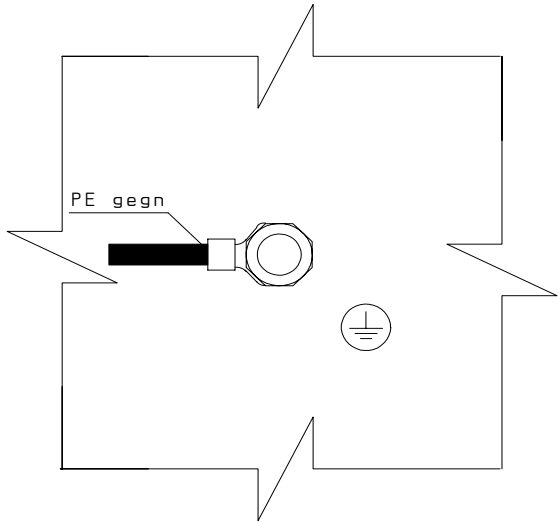

Parts.No Rittal

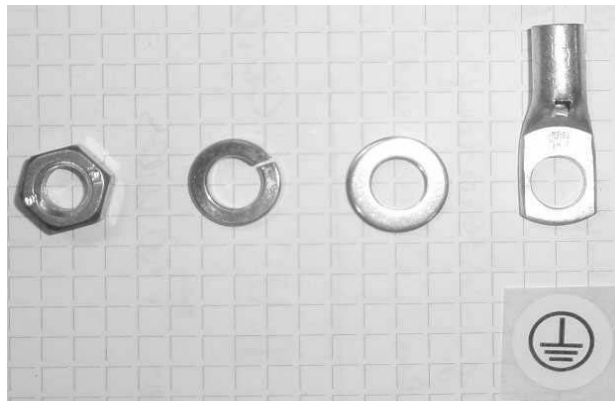
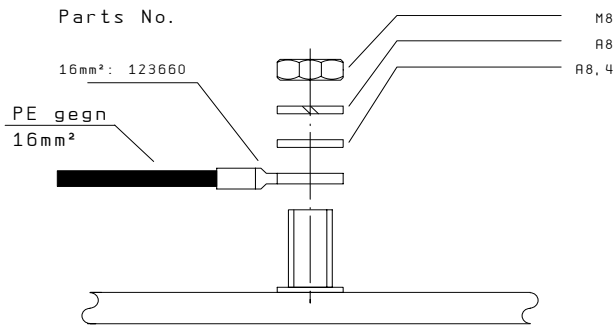

		Date	18.01.06	4 x JGS 320 GS-L.L	 Jenbacher gas engines	Earthing/Grounding Connection A	SD-Nr. Project	8662			
		Desig.	Senfter M.	Nelson Gardens LFG			Suffix	J xxxx			
Modific.	Date	Name	Check	Pieschnik A.			DIR: J:\EPLAN4\VP\ANL\AGEN\WXXX\N7XX\JN795.P	KW 12 - 2012	EPLAN 5	Wiring diagram	J N795 + R1

Grounding Connection

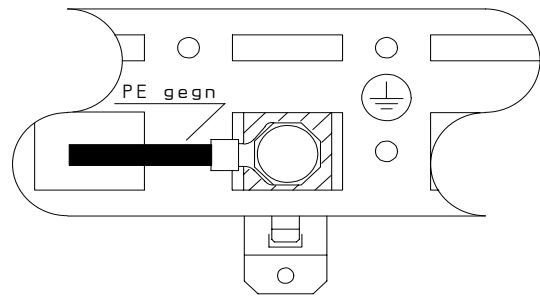

Parts No Rittal

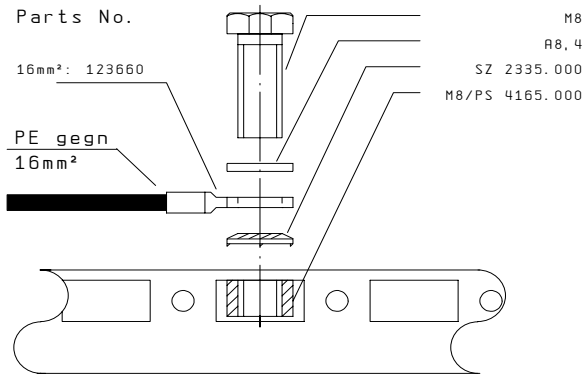

		Date	18.01.06	4 x JGS 320 GS-L.L	Jenbacher gas engines	SD-Nr. Project	8662
		Desig.	Senfter M.	Nelson Gardens LFG		Suffix	J xxxx
		Print	24.04.12			Wiring diagram	J N795 + R1 / 17
Modific.	Date	Name	Check	Pieschnik A.	DIR: J:\EPLAN4\VP\ANL\BEN\WXXX\N7XX\JN795.P	KW 12 - 2012	EPLAN 5

Grounding Connection

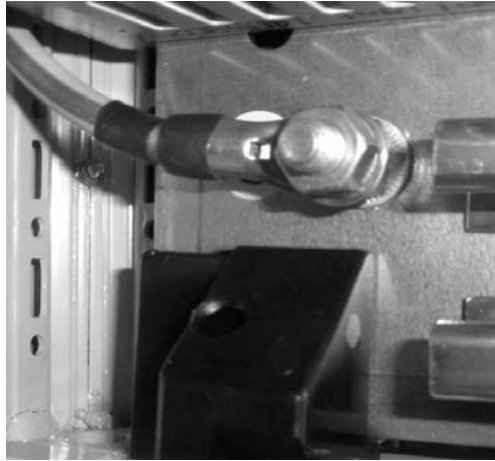
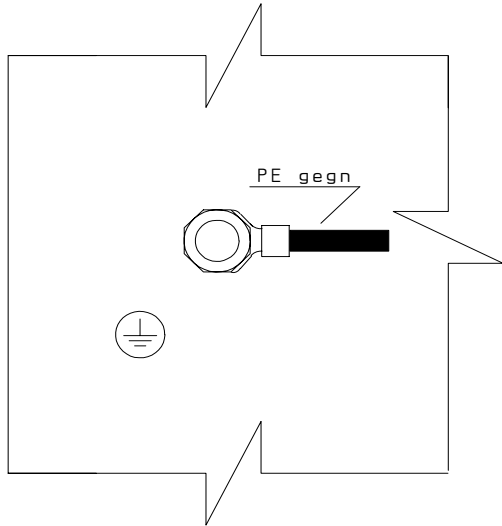

Parts No Rittal

Parts No.

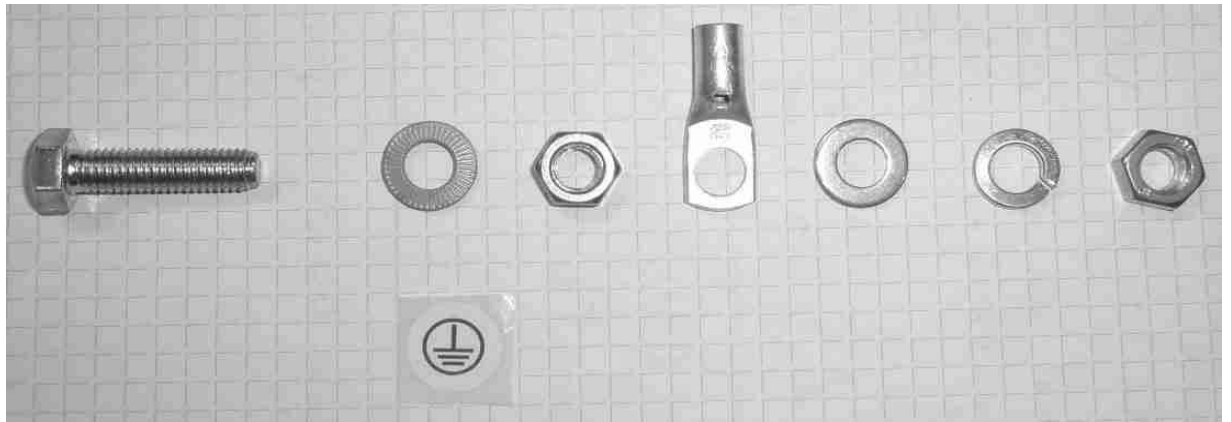
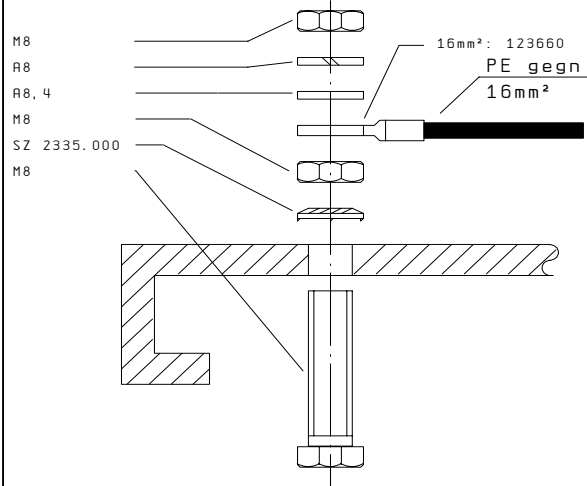

		Date	18.01.06	4 x JGS 320 GS-L.L	 Jenbacher gas engines	Earthing/Grounding Connection C	SD-Nr.	8662
		Desig.	Senfter M.	Nelson Gardens LFG			Suffix	J xxxx
		Print	24.04.12				Wiring diagram	J N795 + R1 / 18
Modific.	Date	Name	Check	Pieschnik A.	DIR: J:\EPLAN4\P\ANL\BEN\WXXX\N7XX\JN795.P	KW 12 - 2012	EPLAN 5	

Grounding Connection

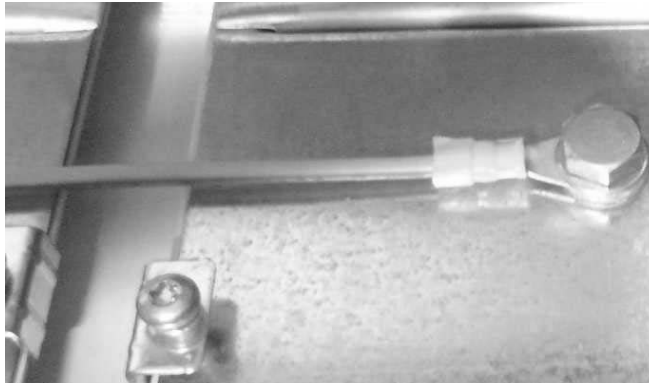
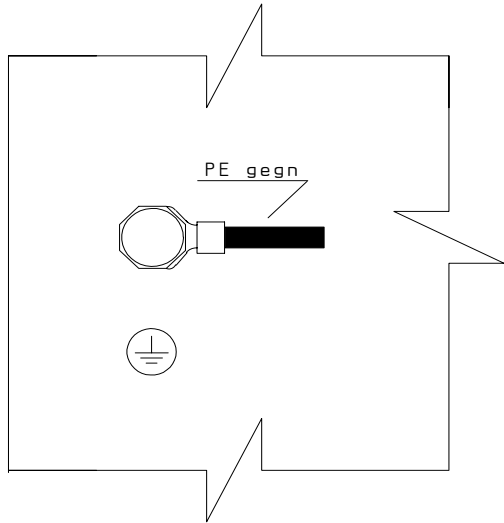

Parts No Rittal

M8
A8, 4
SZ 2335.000

Parts No.

16mm²: 123660

PE gegn
16mm²

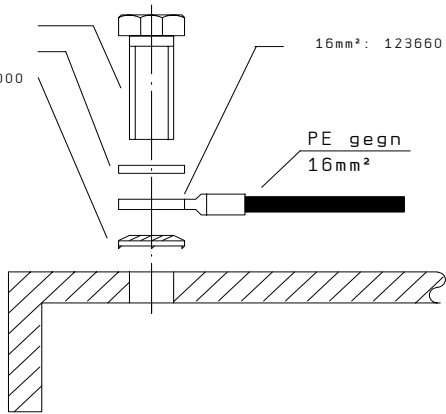

		Date	18.01.06	4 x JGS 320 GS-L.L	 Jenbacher gas engines	Earthing/Grounding Connection D	SD-Nr. Project	8662			
		Desig.	Senfter M.	Nelson Gardens LFG			Suffix	J xxxx			
Modific.	Date	Name	Check	Pieschnik A.			DIR: J:\EPLAN4\VP\ANL\AGEN\WXXX\N7XX\JN795.P	KW 12 - 2012	EPLAN 5	Wiring diagram	J N795 + R1

Mounting plate

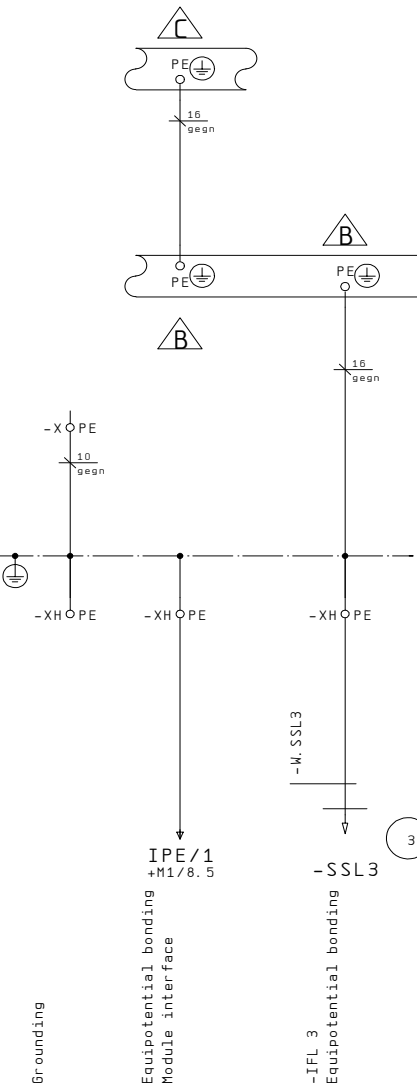

*) all Connections as short as possible
 **) Connection as short as possible
 (possible: contact clip)

Frame Panel

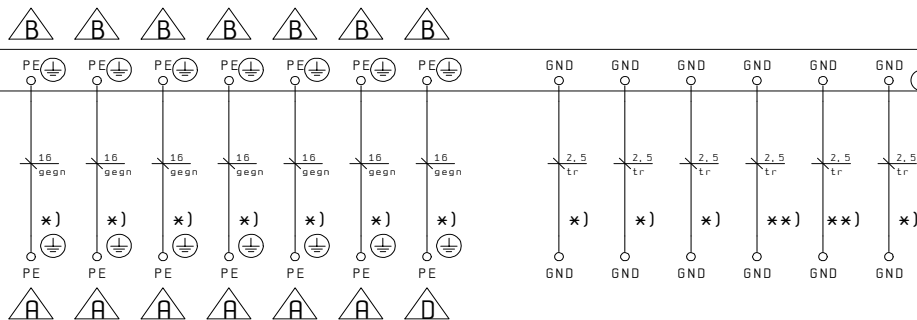

Mit SS gekennzeichnete Klemme ist Schirmerdung mittels Schirmschiene am Schrankeintritt !

Mit E gekennzeichnete Klemmen sind blanke Erdungsklemmen !

With SS indicated terminal is grounding of the shield with Shield bar at the panel entry !

With E indicated Terminals are uninsulated earth terminals !

Earthing/Grounding Connection A - D

		Date	18.01.06	4 x JGS 320 GS-L.L	Jenbacher gas engines	SD-Nr. Project	8662
		Desig.	Senfter M.	Nelson Gardens LFG		Suffix	J xxxx
		Print	24.04.12			Wiring diagram	J N795 + R1 / 20
Modific.	Date	Name	Check	Pieschnik A.	DIR: J:\EPLAN4\VP\ANL\BEN\WXXX\N7XX\JN795.P	KW 12 - 2012	EPLAN 5

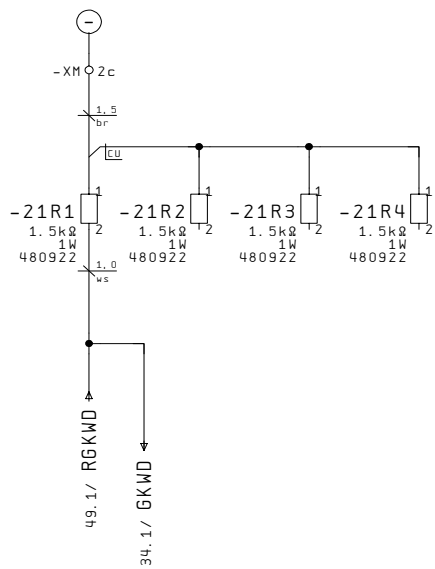

Spare

Resistor - Digital Input

		Date	18.01.06	4 x JGS 320 GS-L.L	 Jenbacher gas engines	Resistors	SD-Nr. Project	8662
		Desig.	Senfter M.	Nelson Gardens LFG			Suffix	J xxxx
		Print	24.04.12				Wiring diagram	J N795 + R1 / 21
Modific.	Date	Name	Check	Pieschnik A.	DIR: J:\EPLAN4\VP\ANLRGEN\WXXX\N7XX\JN795.P	KW 12 - 2012	EPLAN 5	

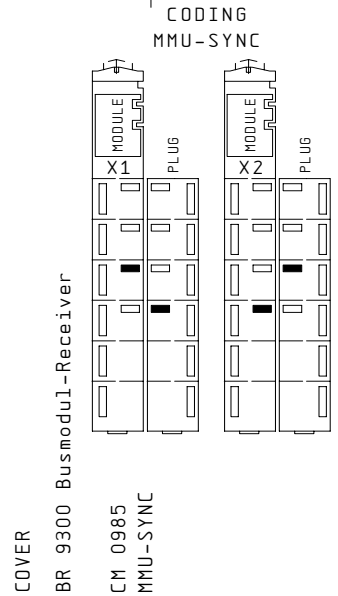
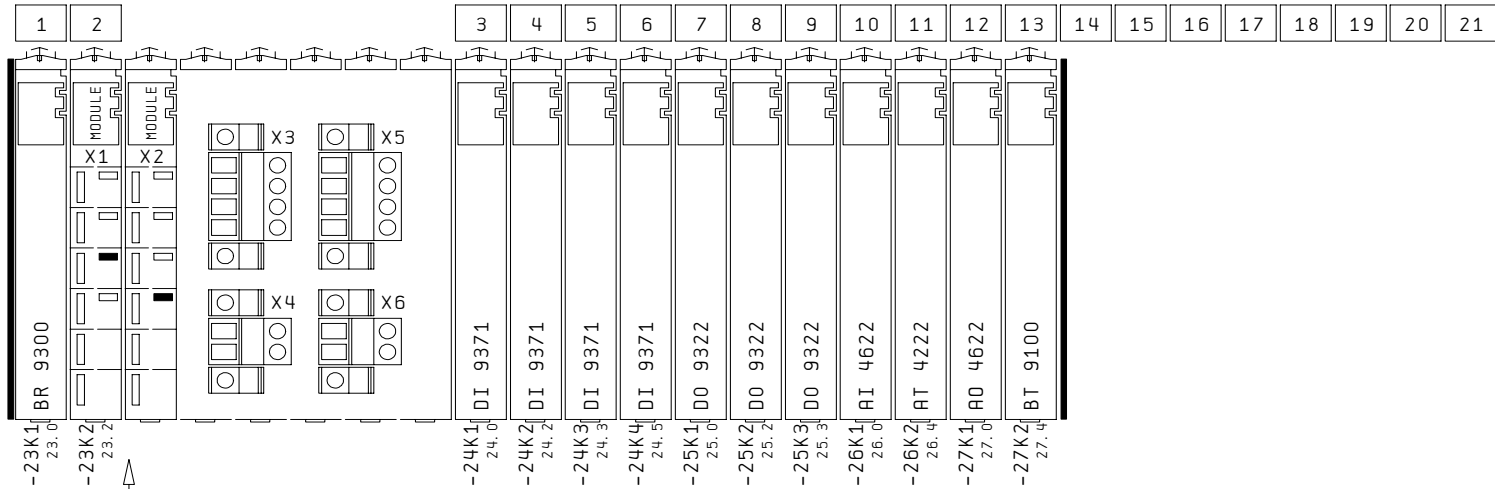

- DI 9371 / 12x DI
- DI 9371 / 12x DI
- DI 9371 / 12x DI
- DI 9371 / 12x DI
- DO 9322 / 12x DO
- DO 9322 / 12x DO
- DO 9322 / 12x DO
- AI 4622 / 4x0-20mA
- AT 4222 / 4xPT100
- AO 4622 / 4x0-20mA / 0-10V
- BT 9100 Busmodul-Transmitter
- COVER

		Date	18.01.06	4 x JGS 320 GS-L.L		Jenbacher gas engines	Over view modules	SD-Nr. Project	8662
		Desig.	Senfter M.	Nelson Gardens LFG				Suffix	J xxxx
		Print	24.04.12					Wiring diagram	J N795 + R1 / 22
Modific.	Date	Name	Check	Pieschnik A.	DIR: J:\EPLAN4\VP\ANL\BEN\WXXX\N7XX\JN795.P	KW 12 - 2012	EPLAN 5		

-23K1
22.1
28.0
436352
530689
436392

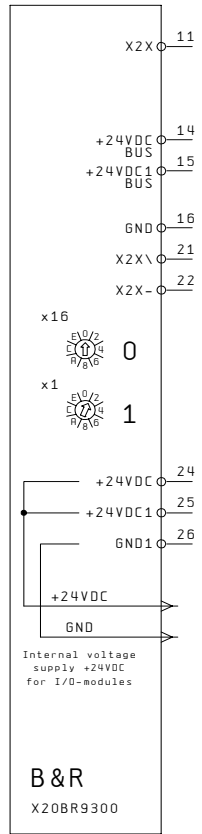

-23K2
22.1
29.0
30.0
31.0
436420
436392
436392
512470
512471
521460
521463

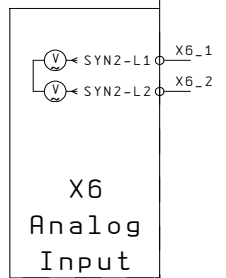
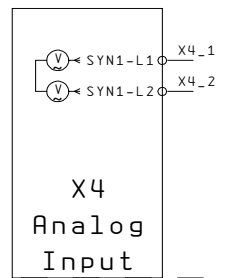
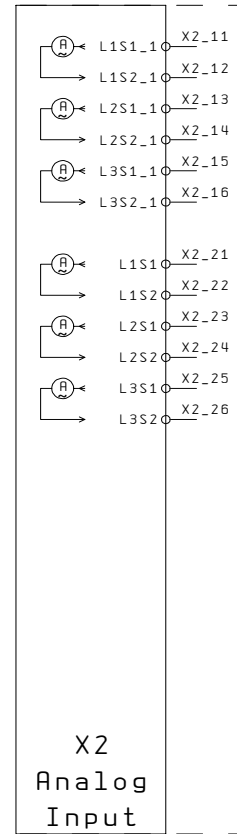
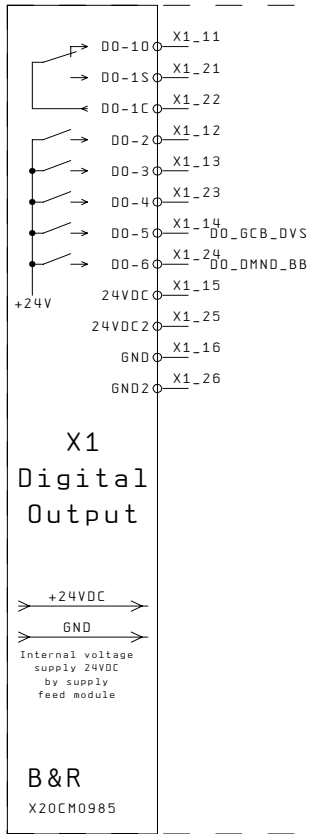

		Date	18.01.06	4 x JGS 320 GS-L.L		Jenbacher gas engines	Slot address Over view		SD-Nr. Project	8662
		Desig.	Senfter M.	Nelson Gardens LFG			Suffix	J xxxx		
		Print	24.04.12				Wiring diagram	J N795 + R1 / 23		
Modific.	Date	Name	Check	Pieschnik A.	DIR: J:\EPLAN4\P\ANL\BEN\WXXX\N7XX\JN795.P	KW 12 - 2012	EPLAN 5			

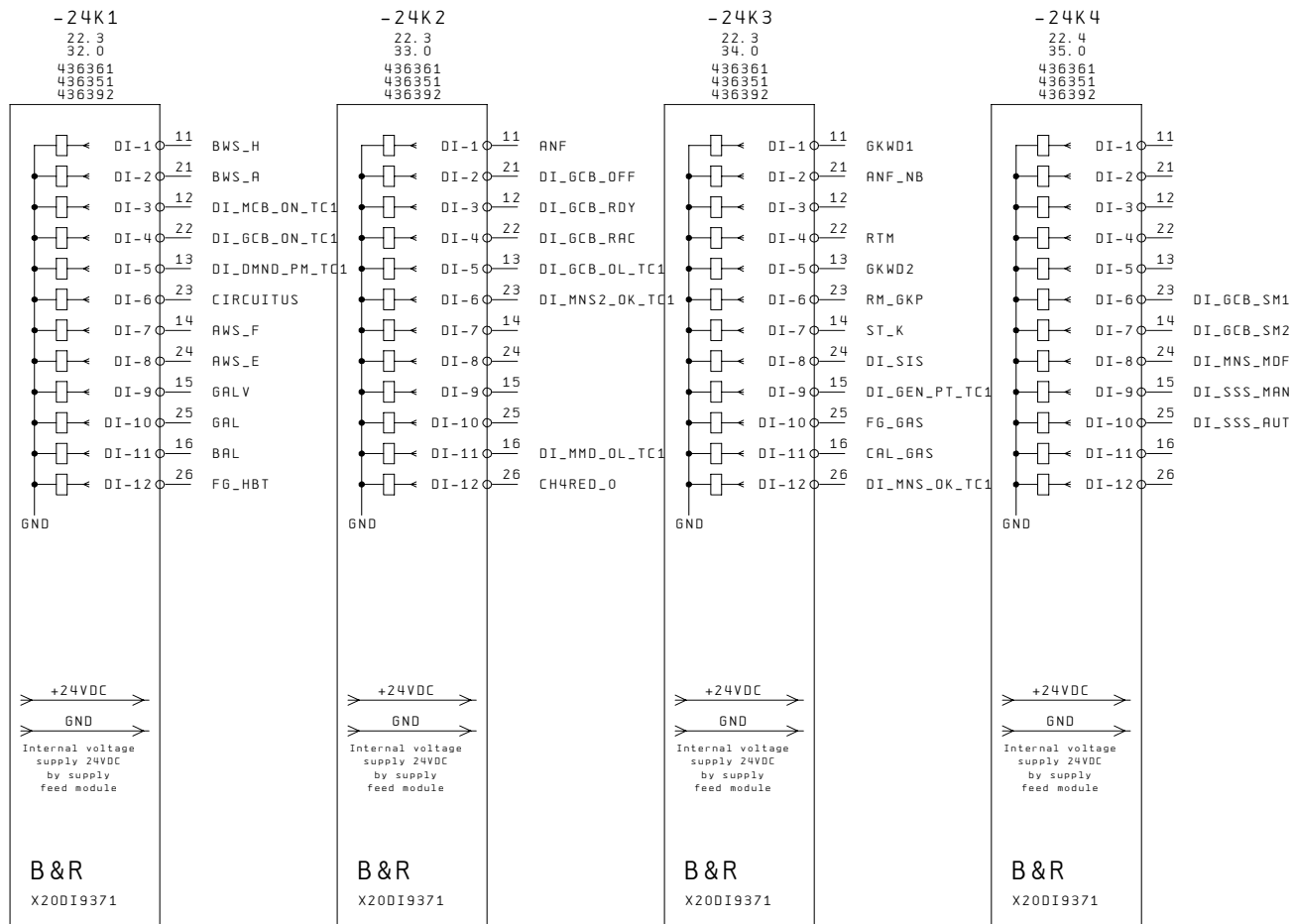

		Date	18.01.06	4 x JGS 320 GS-L.L	 Jenbacher gas engines	Slot address Over view	SD-Nr. Project	8662
		Desig.	Senfter M.	Nelson Gardens LFG			Suffix	J xxxx
		Print	24.04.12				Wiring diagram	J N795 + R1 / 24
Modific.	Date	Name	Check	Pieschnik A.	DIR: J:\EPLAN4\P\ANL\BEN\WXXX\N7XX\JN795.P	KW 12 - 2012	EPLAN 5	

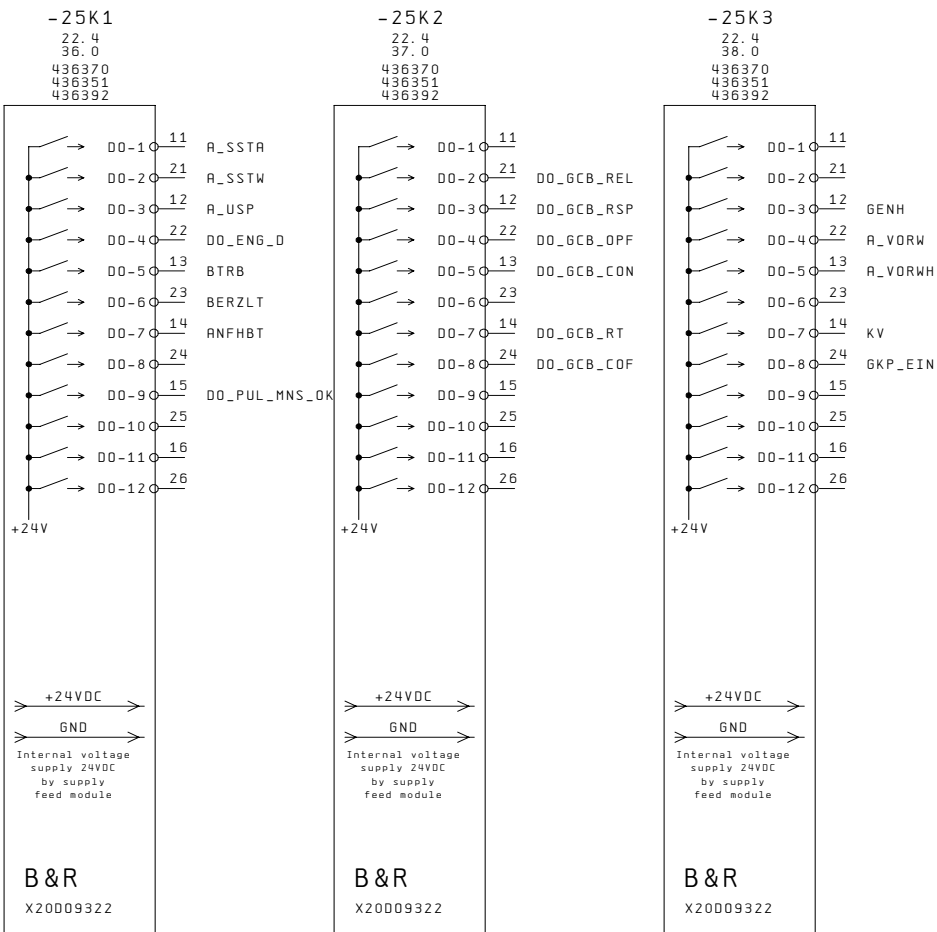

		Date	18.01.06	4 x JGS 320 GS-L.L	 Jenbacher gas engines	Slot address Over view		SD-Nr. Project	8662
		Desig.	Senfter M.	Nelson Gardens LFG		Suffix	J xxxx		
		Print	24.04.12			Wiring diagram	J N795 + R1 / 25		
Modific.	Date	Name	Check	Pieschnik A.	DIR: J:\EPLAN4\VP\ANL\BEN\WXXX\N7XX\JN795.P	KW 12 - 2012	EPLAN 5		

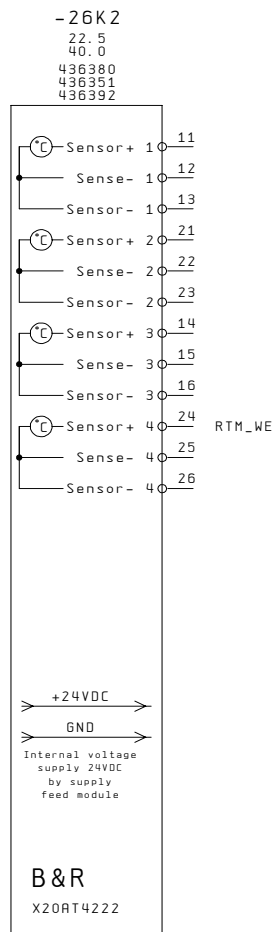
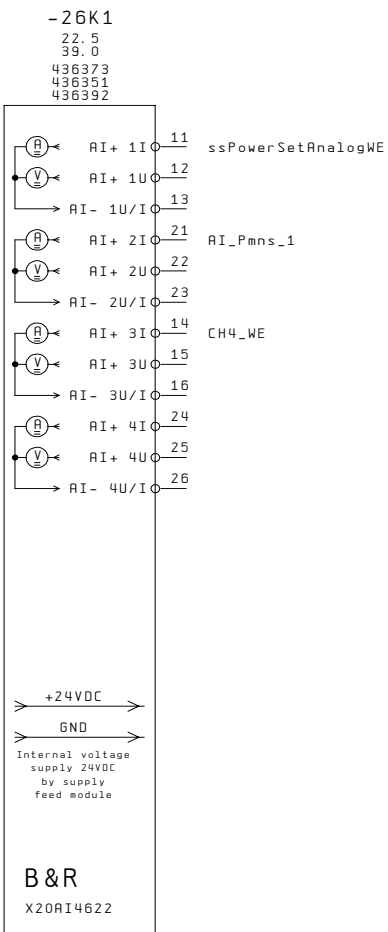

		Date	18.01.06	4 x JGS 320 GS-L.L	Jenbacher gas engines Slot address Over view	SD-Nr. Project	8662
		Desig.	Senfter M.	Nelson Gardens LFG		Suffix	J xxxx
		Print	24.04.12			Wiring diagram	J N795 + R1 / 26
Modific.	Date	Name	Check	Pieschnik A.	DIR: J:\EPLAN4\PLANL\GEN\WXXX\N7XX\JN795.P	KW 12 - 2012	EPLAN 5

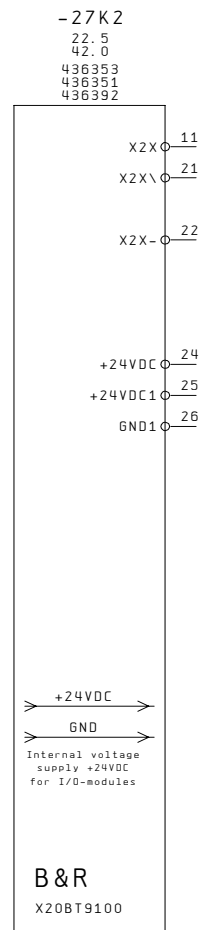
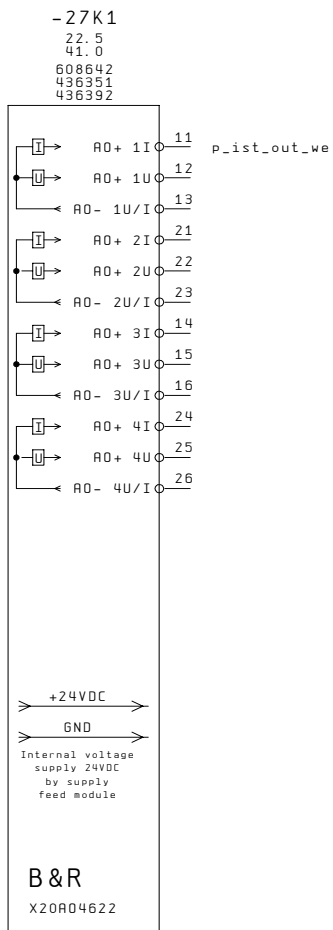

		Date	18.01.06	4 x JGS 320 GS-L.L	Jenbacher gas engines	Slot address Over view	SD-Nr. Project	8662
		Desig.	Senfter M.	Nelson Gardens LFG			Suffix	J xxxx
		Print	24.04.12				Wiring diagram	J N795 + R1 / 27
Modific.	Date	Name	Check	Pieschnik A.	DIR: J:\EPLAN4\PLANL\GEN\XXXX\N7XX\JN795.P	KW 12 - 2012	EPLAN 5	

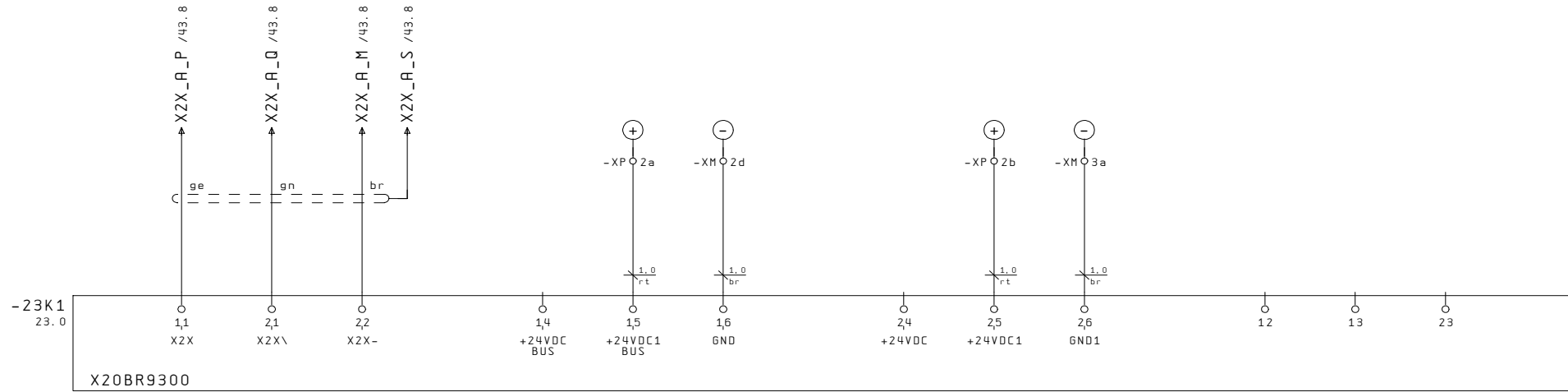

X2X ----> Module control panel

Supply PLC

		Date	18.01.06	4 x JGS 320 GS-L.L	 Jenbacher gas engines	BUS-RECEIVER	SD-Nr.	8662
		Desig.	Senfter M.	Nelson Gardens LFG			Suffix	J xxxx
		Print	24.04.12				Wiring diagram	J N795 + R1 / 28
Modific.	Date	Name	Check	Pieschnik A.	DIR: J:\EPLAN4\VP\ANL\GEN\WXXX\N7XX\JN795.P	KW 12 - 2012	EPLAN 5	

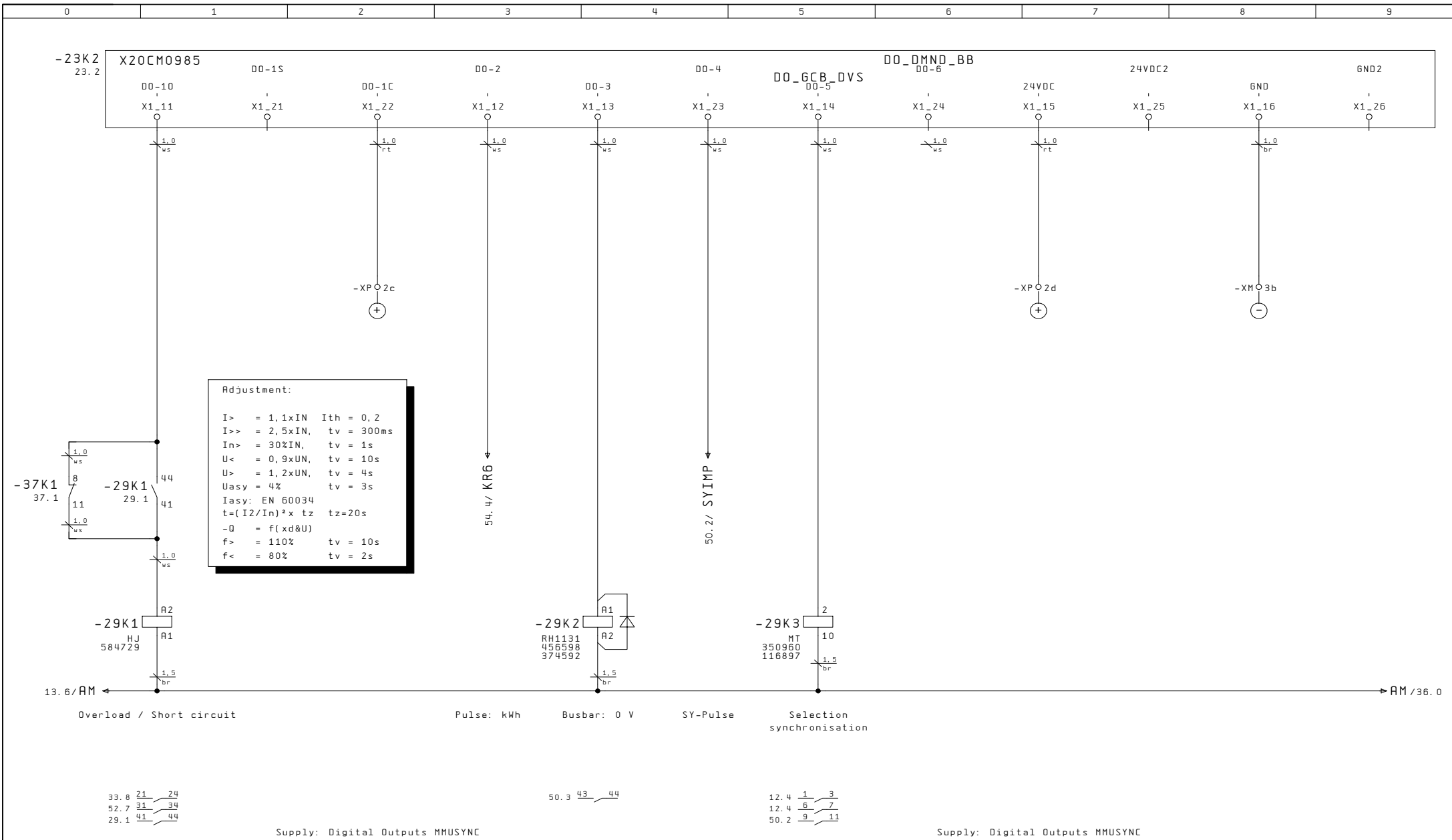

	Date	18.01.06	4 x JGS 320 GS-L.L	Jenbacher gas engines	Multi measuring and monitoring device	SD-Nr. Project	8662
	Desig.	Senfter M.	Nelson Gardens LFG			Suffix	J xxxx
	Print	24.04.12				Wiring diagram	J N795 + A1 / 29
Modific.	Date	Name	Check	Pieschnik A.	DIR: J:\EPLAN4\VP\ANL\BEN\WXXX\N7XX\JN795.P	KW 12 - 2012	EPLAN 5

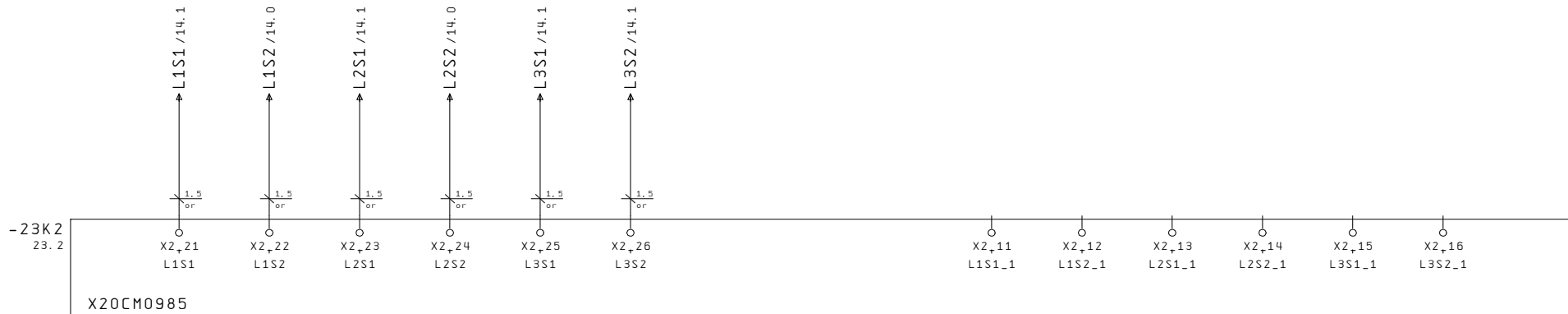

Generator current

			Date	18.01.06	4 x JGS 320 GS-L.L	 Jenbacher gas engines	Multi measuring and monitoring device	SD-Nr. Project	8662
			Desig.	Senfter M.	Nelson Gardens LFG			Suffix	J xxxx
			Print	24.04.12				Wiring diagram	J N795 + R1
Modific.	Date	Name	Check	Pieschnik R.	DIR: J:\EPLAN4\PROJ\ANLAGEN\N795\N795.P	KW 12 - 2012	EPLAN 5		

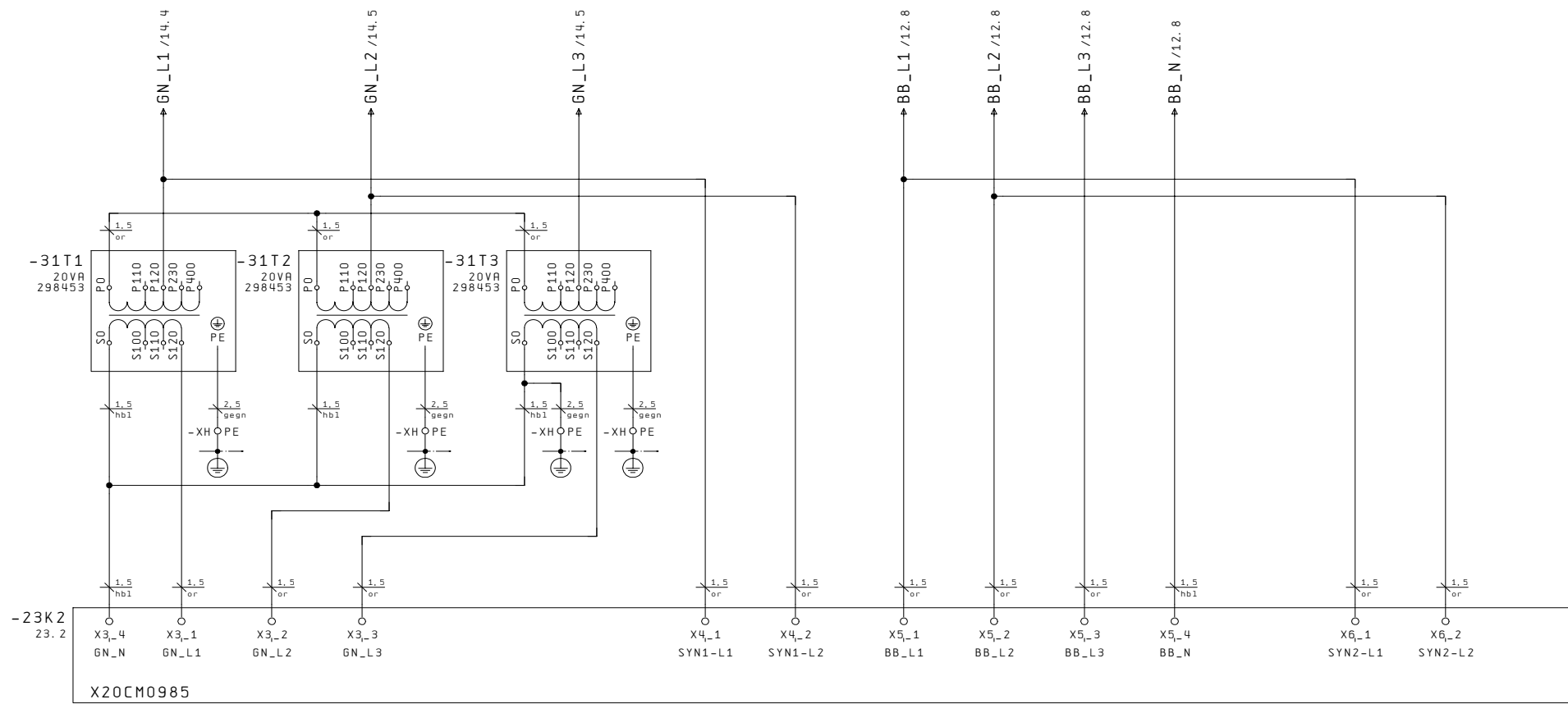

Generator voltage

Voltage 1

Busbar voltage

Voltage 2

		Date	18.01.06	4 x JGS 320 GS-L.L	 Jenbacher gas engines	Multi measuring and monitoring device	SD-Nr. Project	8662
		Desig.	Senfter M.	Nelson Gardens LFG			Suffix	J xxxx
		Print	24.04.12				Wiring diagram	J N795 + R1 / 31
Modific.	Date	Name	Check	Pieschnik A.	DIR: J:\EPLAN4\VP\ANL\BEN\WXXX\N7XX\JN795.P	KW 12 - 2012	EPLAN 5	

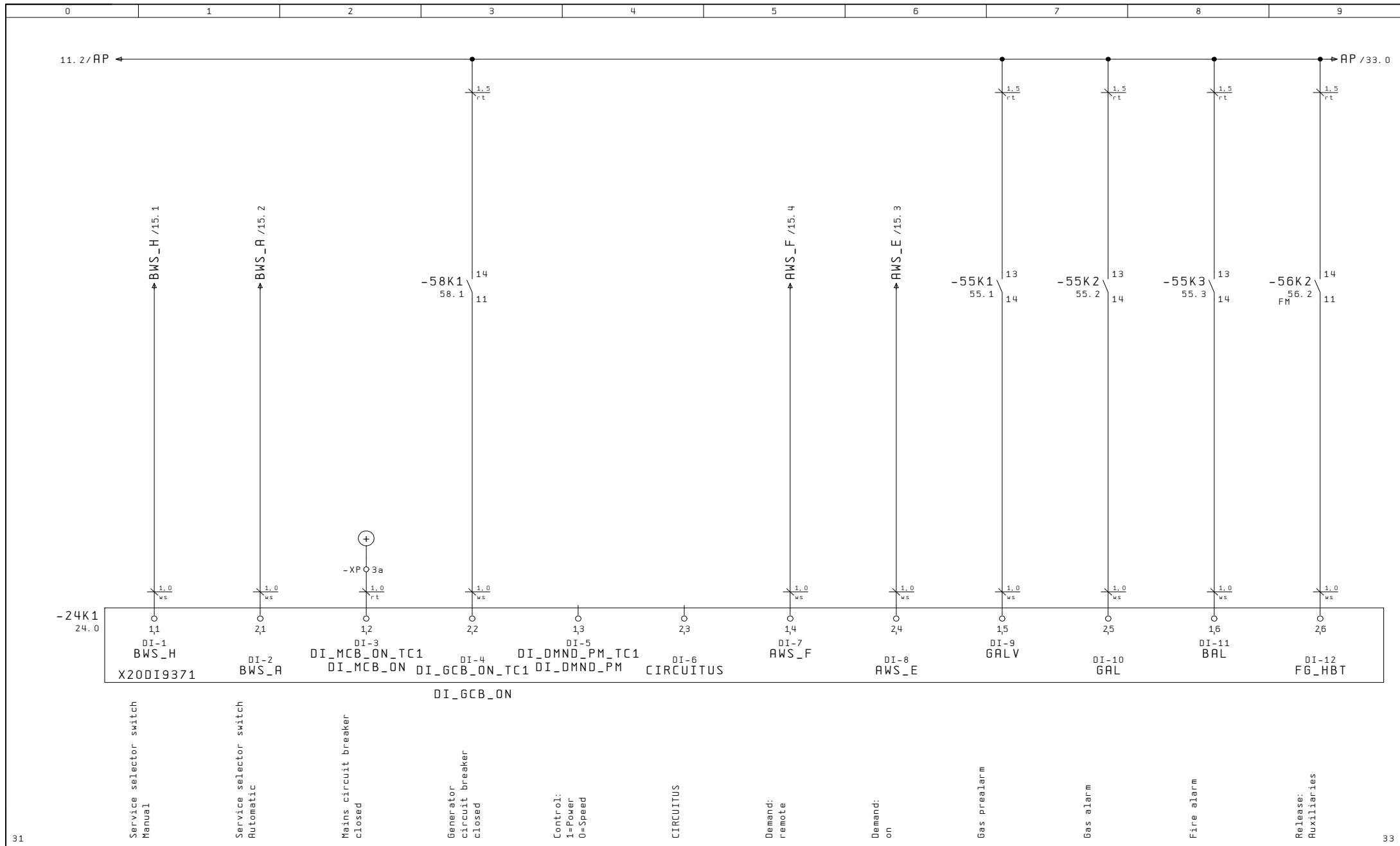

31

33

Modific.	Date	Name	Check	Pieschnik A.	DIR: J:\EPLAN4\VP\ANL\BEN\WXXX\N7XX\JN795.P	KW 12 - 2012		Jenbacher gas engines	Digital Inputs	SD-Nr. Project	8662
										Suffix	J xxxx
										Wiring diagram	J N795 + R1 / 32

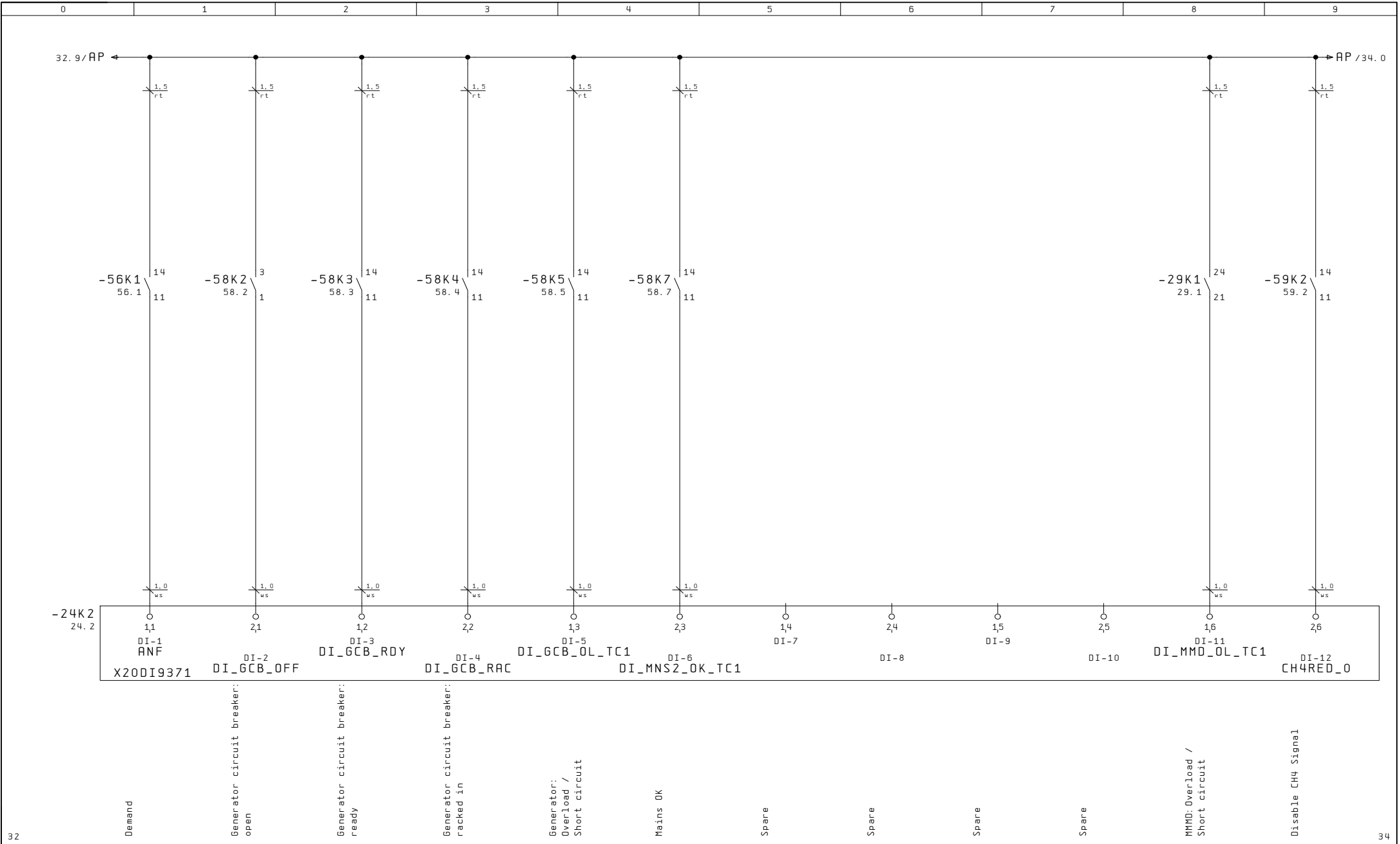

32			Date	18.01.06	4 x JGS 320 GS-L.L	 Jenbacher gas engines	Digital Inputs	SD-Nr. Project	8662
			Desig.	Senfter M.	Nelson Gardens LFG		Suffix	J xxxx	
			Print	24.04.12			Wiring diagram	J N795 + R1 / 33	
Modific.	Date	Name	Check	Pieschnik A.	DIR: J:\EPLAN4\VP\ANL\BEN\WXXX\N7XX\JN795.P	KW 12 - 2012	EPLAN 5		

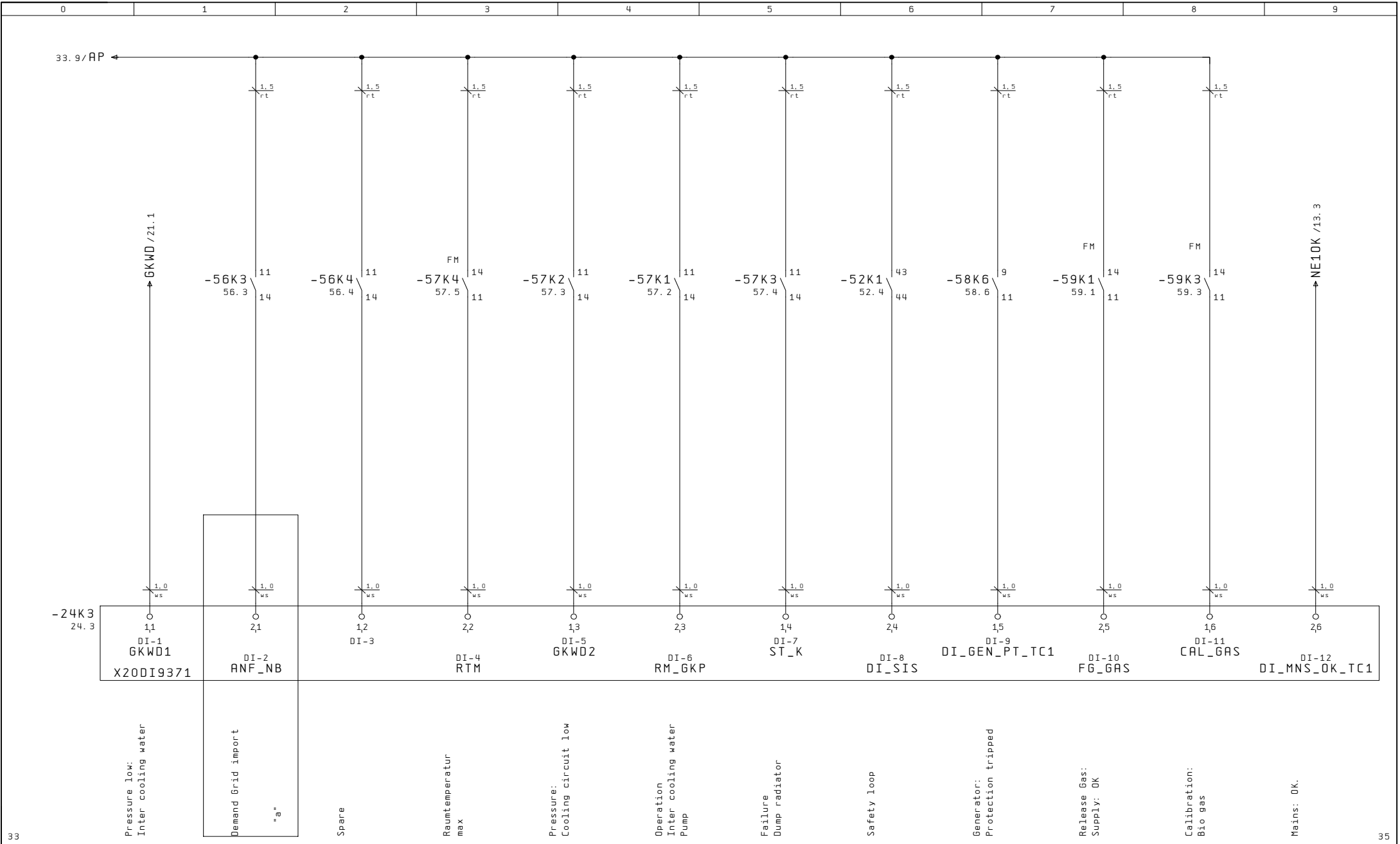

a		Date	18.01.06	4 x JGS 320 GS-L.L		 Jenbacher gas engines	Digital Inputs		SD-Nr. Project	8662
		Desig.	Senfter M.	Nelson Gardens LFG			Suffix	J xxxx		
		Print	24.04.12				Wiring diagram	J N795 + R1 / 34		
Modific.	Date	Name	Check	Pieschnik A.	DIR: J:\EPLAN4\VP\ANL\BEN\WXXX\N7XX\JN795.P	KW 12 - 2012	EPLAN 5			

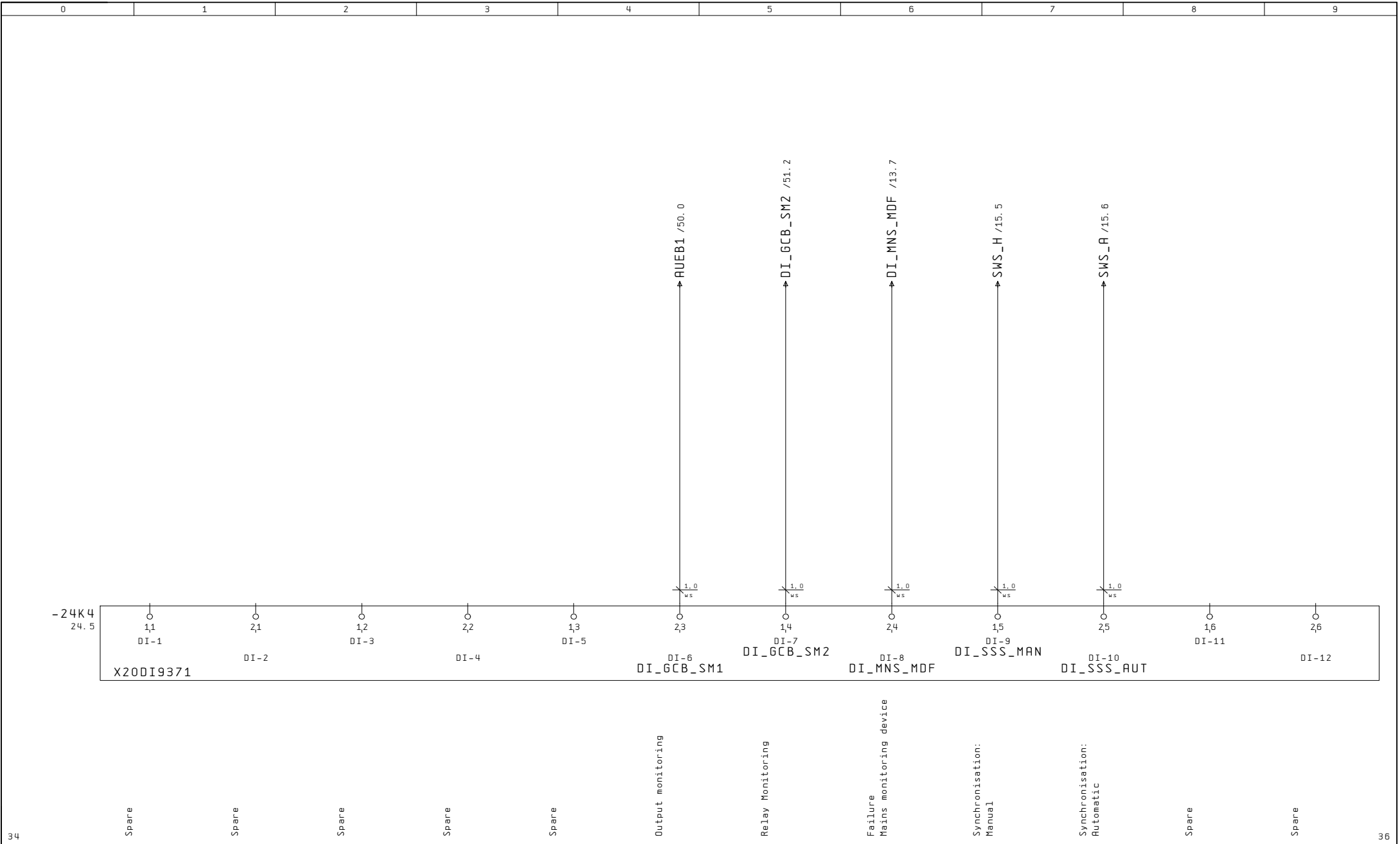

34			Date	18.01.06	4 x JGS 320 GS-L.L
			Desig.	Senfter M.	
			Print	24.04.12	Nelson Gardens LFG
Modific.	Date	Name	Check	Pieschnik A.	DIR: J:\EPLAN4\VP\ANL\BEN\XXXX\N7XX\JN795.P

Jenbacher
 gas engines

Digital Inputs	
SD-Nr. Project	8662
Suffix	J xxxx
Wiring diagram	J N795 + R1 / 35

SD-Nr. Project	8662
Suffix	J xxxx
Wiring diagram	J N795 + R1 / 35

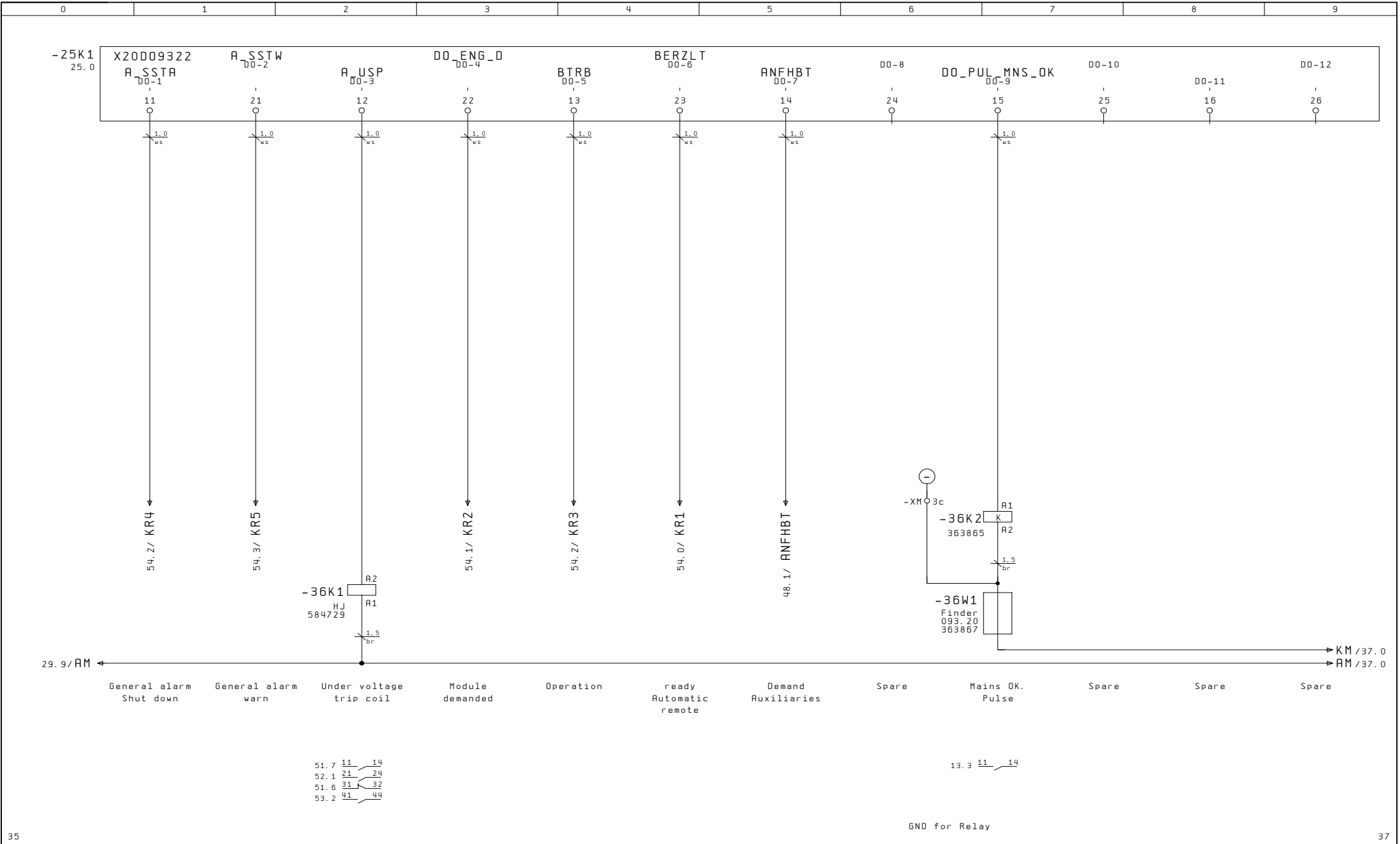

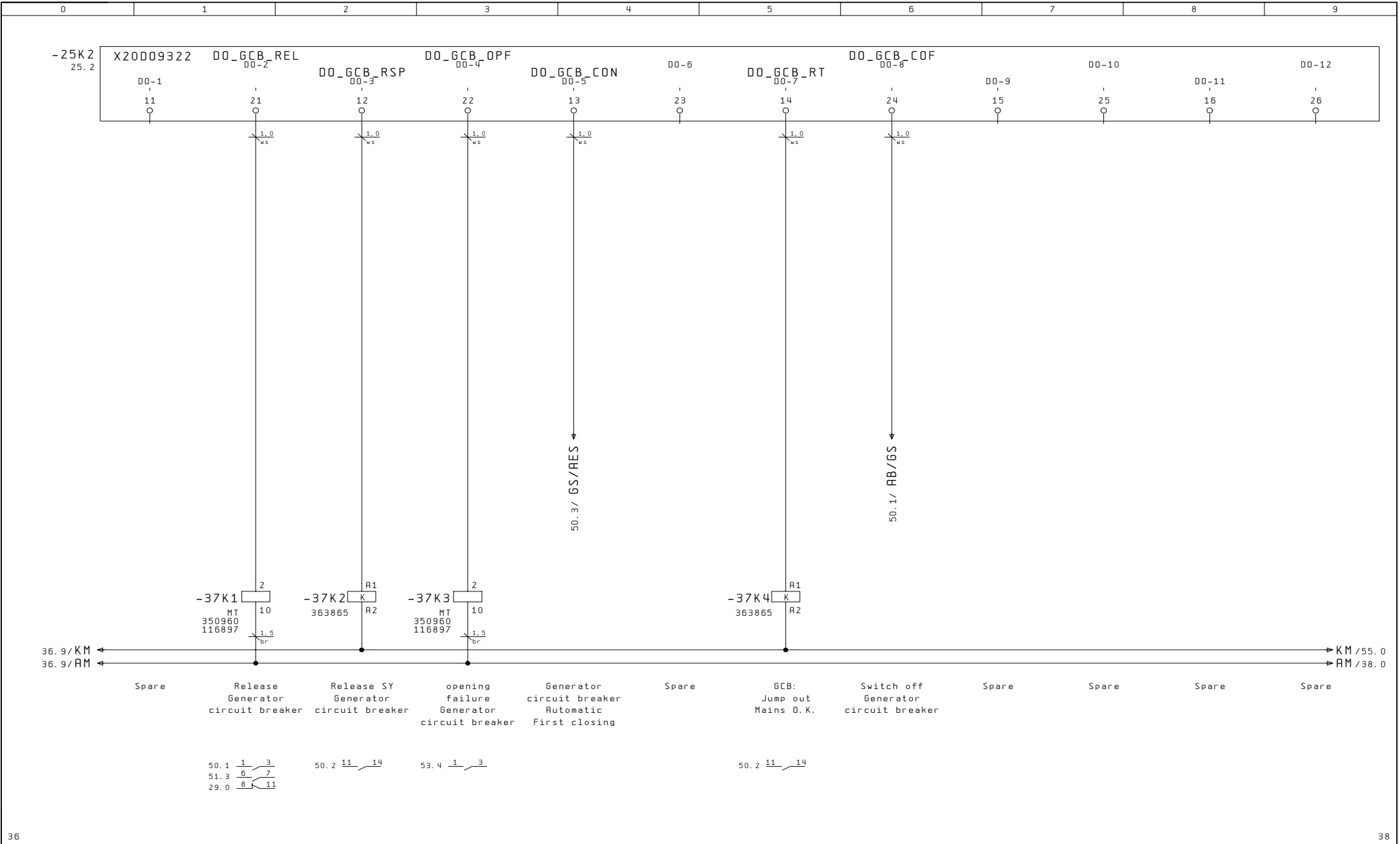

GND for Relay

		Date	18.01.06	4 x JGS 320 GS-L.L		Jenbacher gas engines	Digital Outputs		SD-Nr. Project	8662
		Desig.	Senfter M.	Nelson Gardens LFG					Suffix	J xxxx
		Print	24.04.12						Wiring diagram	J N795 + A1 / 36
Modific.	Date	Name	Check	Pieschnik A.	DIR: J:\EPLAN4\VP\ANL\BEN\WXXX\N7XX\JN795.P	KW 12 - 2012	EPLAN 5			

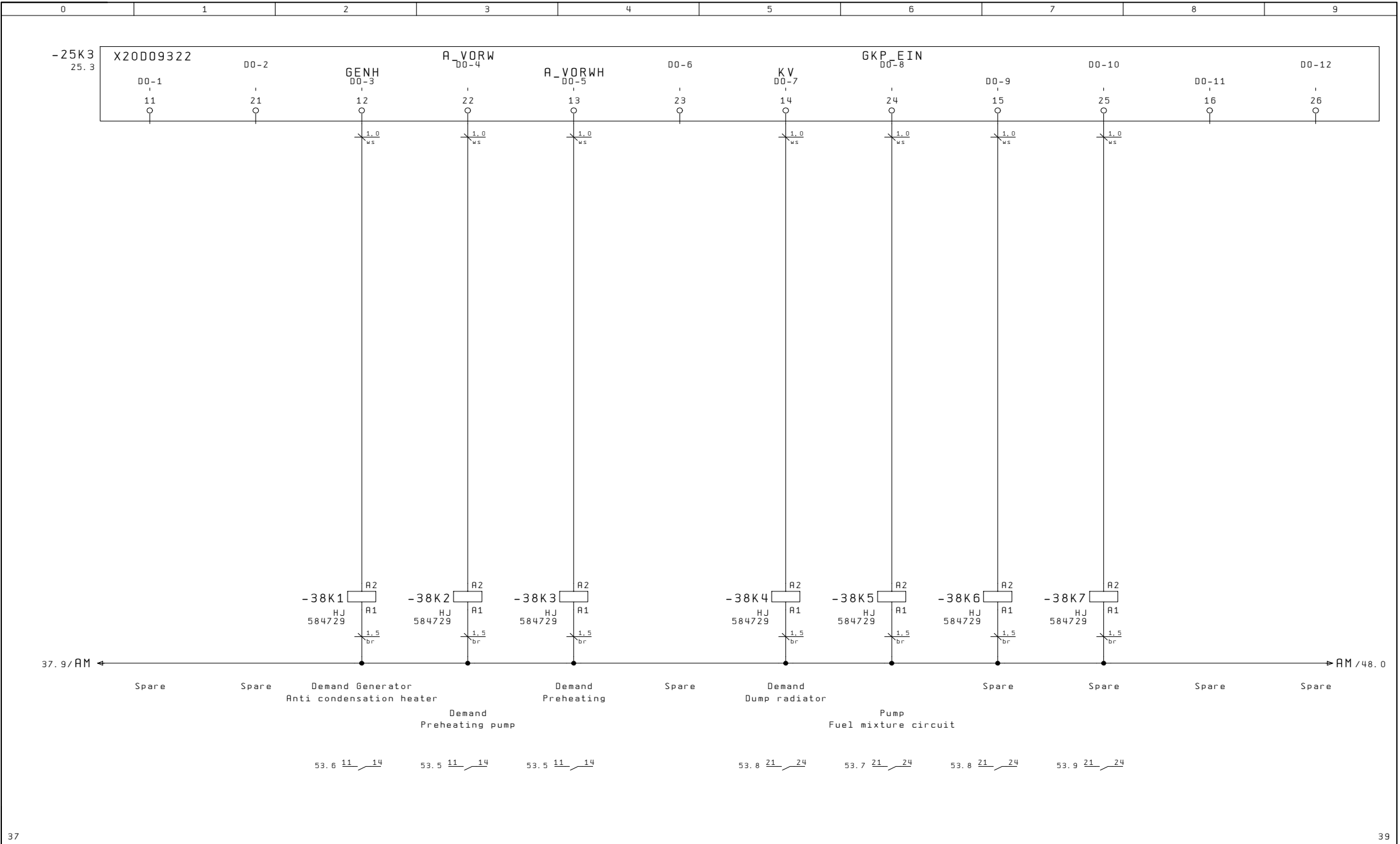

		Date	18.01.06	4 x JGS 320 GS-L.L	 Jenbacher gas engines	Digital Outputs	SD-Nr. Project	8662
		Desig.	Senfter M.	Nelson Gardens LFG		Suffix	J xxxx	
		Print	24.04.12			Wiring diagram	J N795 + A1 / 37	
Modific.	Date	Name	Check	Pieschnik A.	DIR: J:\EPLAN4\VP\ANL\BEN\WXXX\N7XX\JN795.P	KW 12 - 2012	EPLAN 5	



		Date	18.01.06	4 x JGS 320 GS-L.L	 Jenbacher gas engines	Digital Outputs	SD-Nr. Project	8662
		Desig.	Senfter M.	Nelson Gardens LFG		Suffix	J xxxx	
		Print	24.04.12			Wiring diagram	J N795 + A1 / 38	
Modific.	Date	Name	Check	Pieschnik A.	DIR: J:\EPLAN4\VP\ANL\BEN\WXXX\N7XX\JN795.P	KW 12 - 2012	EPLAN 5	

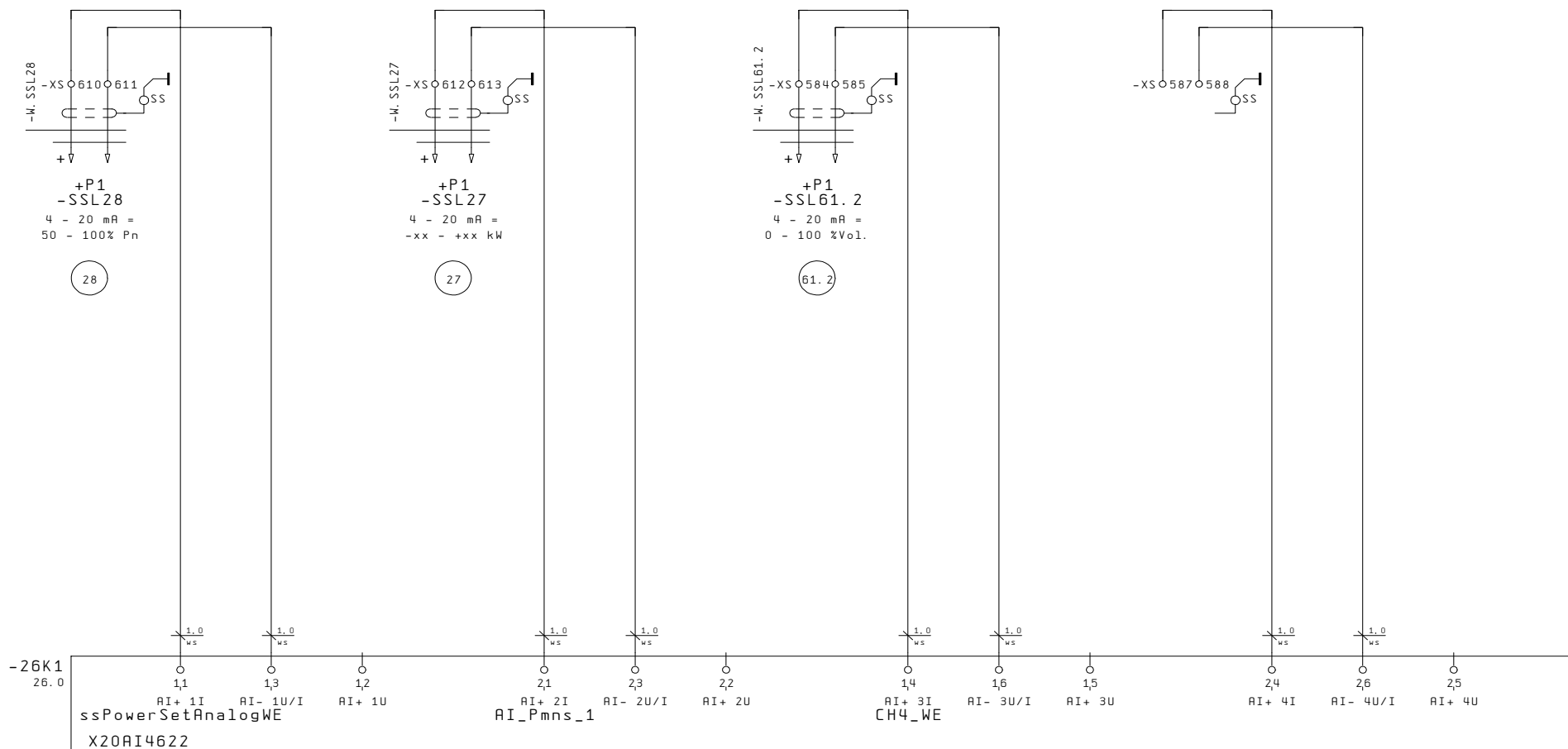

-26K1
26.0

-IFL 28
External Set point power

-IFL27
External Decrease load

-IFL 61.2
Content: CH4 Collect line

Spare

		Date	18.01.06	4 x JGS 320 GS-L.L	Jenbacher gas engines	Analog Inputs	SD-Nr. Project	8662
		Desig.	Senfter M.	Nelson Gardens LFG		Suffix	J xxxx	
		Print	24.04.12			Wiring diagram	J N795 + R1 / 39	
Modific.	Date	Name	Check	Pieschnik A.	DIR: J:\EPLAN4\VP\ANL\BEN\WXXX\N7XX\JN795.P	KW 12 - 2012	EPLAN 5	

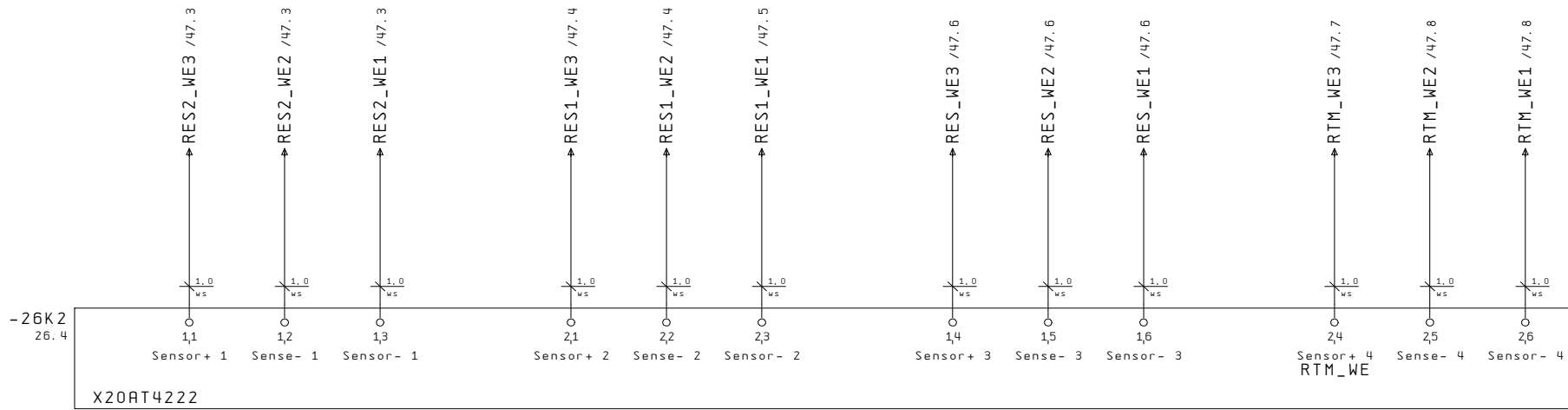

		Date	18.01.06	4 x JGS 320 GS-L.L	 Jenbacher gas engines	Analog Inputs	SD-Nr. Project	8662	
		Desig.	Senfter M.	Nelson Gardens LFG			Suffix	J xxxx	
Modific.	Date	Name	Check	Pieschnik A.			DIR: J:\EPLAN4\PROJ\ANLAGEN\XXXX\N7XX\N795.P	KW 12 - 2012	EPLAN 5

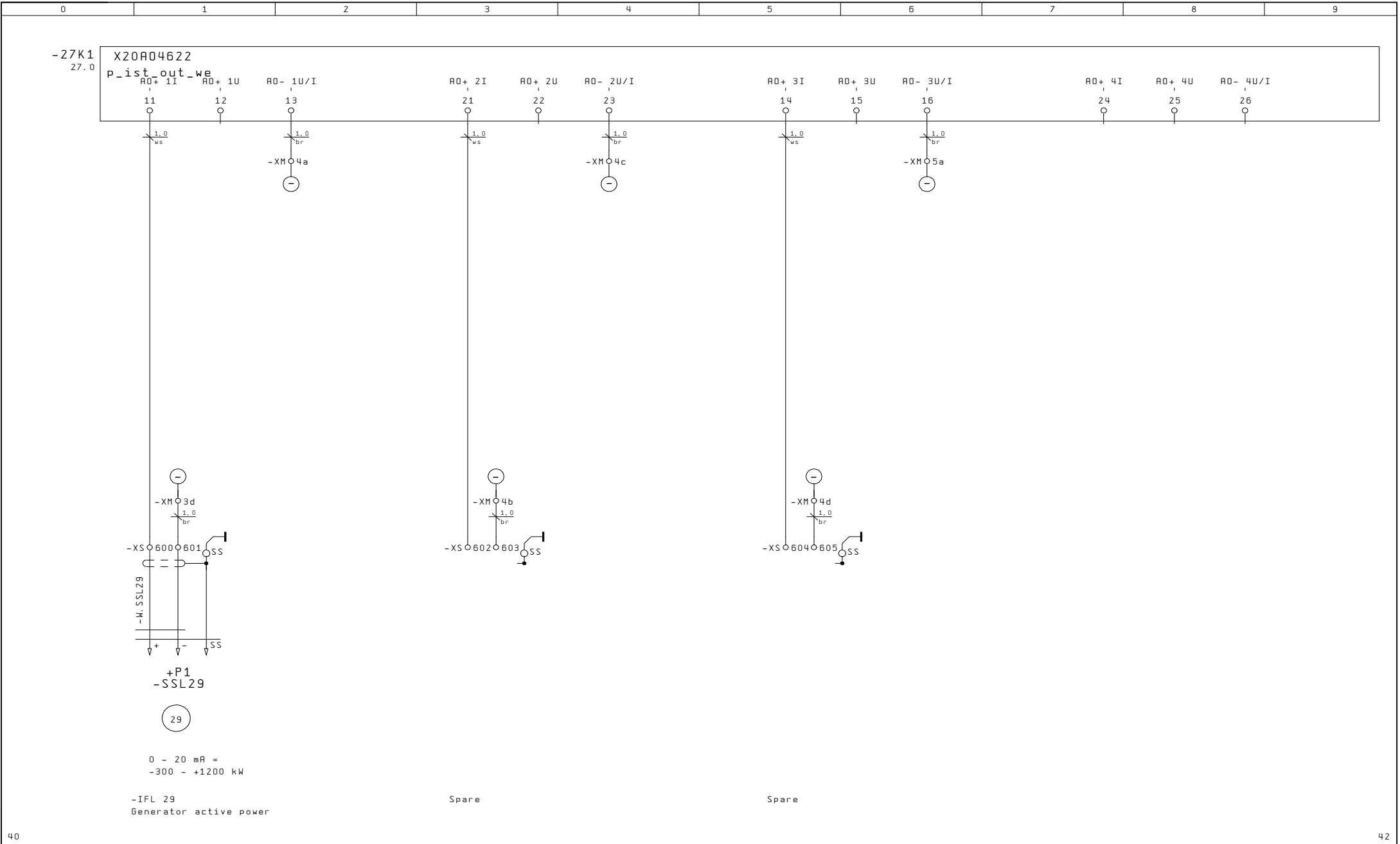

		Date	18.01.06	4 x JGS 320 GS-L.L	 Jenbacher gas engines	Analog Outputs	SD-Nr. Project	8662
		Desig.	Senfter M.	Nelson Gardens LFG			Suffix	J xxxx
		Print	24.04.12				Wiring diagram	J N795 + R1 / 41
Modific.	Date	Name	Check	Pieschnik A.	DIR: J:\EPLAN4\VP\ANL\BEN\WXXX\N7XX\JN795.P	KW 12 - 2012	EPLAN 5	

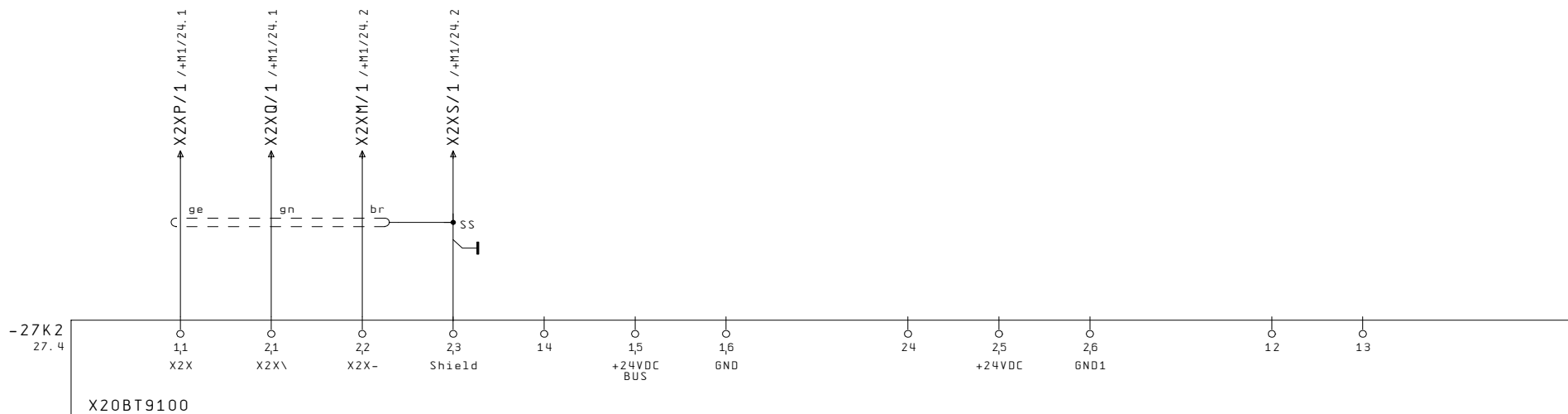

X2X ---> Module interface

		Date	18.01.06	4 x JGS 320 GS-L.L	 Jenbacher gas engines	BUS-TRANSMITTER	SD-Nr. Project	8662
		Desig.	Senfter M.	Nelson Gardens LFG			Suffix	J xxxx
		Print	24.04.12				Wiring diagram	J N795 + R1 / 42
Modific.	Date	Name	Check	Pieschnik A.	DIR: J:\EPLAN4\VP\ANL\BEN\WXXX\N7XX\JN795.P	KW 12 - 2012	EPLAN 5	

SET: 632146

-43K1
628269

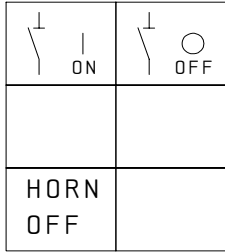

DISPLAY



-43C1
256MB Flash
628273

Engine Number:

- 1 = 0B
- 2 = 0C
- 3 = 0D
- 4 = 0E
- 5 = 0F
- 6 = 10
- 7 = 11
- 8 = 12
- 9 = 13
- 10 = 14

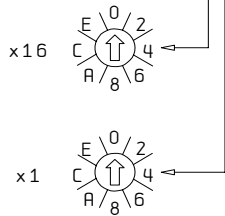

--> SWITCH

-43K2 RXD TXD
3 IF779.9 IF1
SLOT1
442076

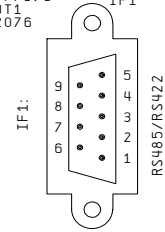

Plug

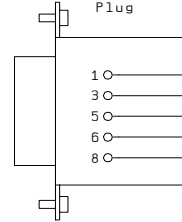

- MOD1 /45.3
- MOD3 /45.3
- MOD5 /45.3
- MOD6 /45.3
- MOD8 /45.3

CAN 0 X2X

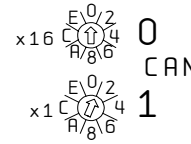

- CANH /46.2
- CANG /46.2
- CANL /46.2
- CANS /46.2

-43X1
525630

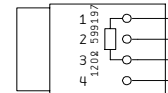

-W. I4, A
X2X 4x0,34mm²
violet

- X2X_A_P /28.1
- X2X_A_M /28.2
- X2X_A_Q /28.1
- X2X_A_S /28.2

-43X2
525630

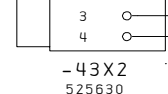

CAN-Bus

X2X

		Date	18.01.06	4 x JGS 320 GS-L.L	Jenbacher gas engines	Powerpanel XT3	SD-Nr.	8662
		Desig.	Senfter M.	Nelson Gardens LFG			Suffix	J xxxx
		Print	24.04.12				Wiring diagram	J N795 + A1 / 43
Modific.	Date	Name	Check	Pieschnik A.	DIR: J:\EPLAN4\VP\ANL\BEN\WXXX\N7XX\JN795.P	KW 12 - 2012	EPLAN 5	

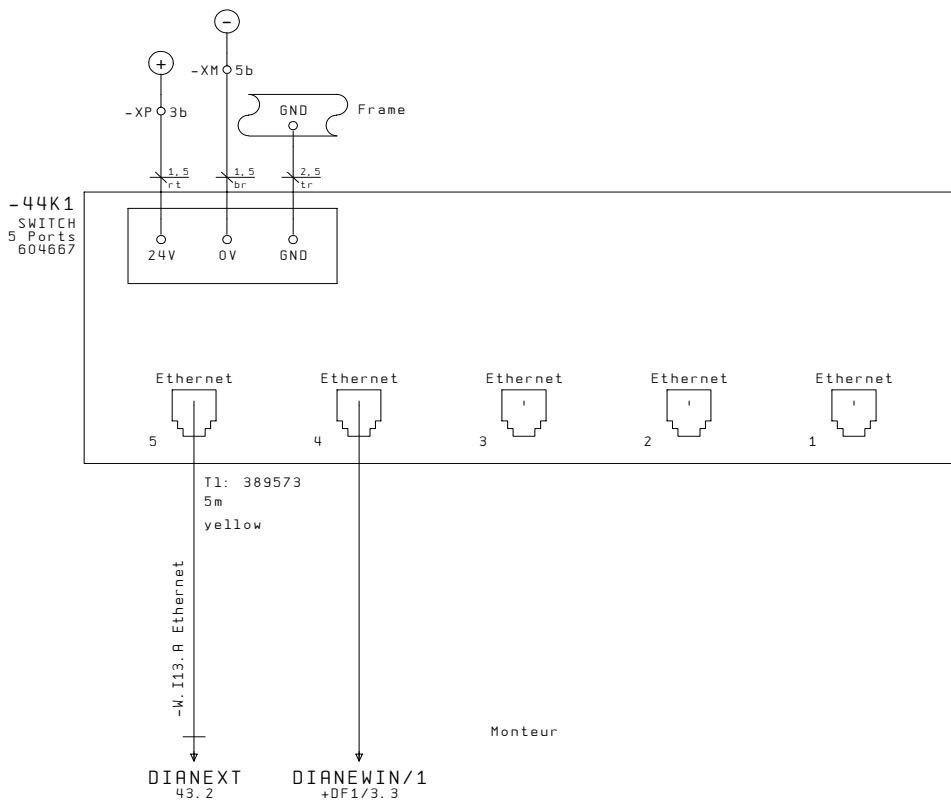

Switch --> PP450 WINSERVER 1

		Date	18.01.06	4 x JGS 320 GS-L.L	 Jenbacher gas engines	SWITCH	SD-Nr. Project	8662
		Desig.	Senfter M.	Nelson Gardens LFG		Suffix	J xxxx	
		Print	24.04.12			Wiring diagram	J N795 + R1 / 44	
Modific.	Date	Name	Check	Pieschnik A.	DIR: J:\EPLAN4\VP\ANL\BEN\WXXX\N7XX\JN795.P	KW 12 - 2012	EPLAN 5	

Zwischen der GE Jenbacher-Steuerung und dem bauseitigen Computer ist bauseits ein Potentialausgleich herzustellen.

Between the GE Jenbacher-Control and the Customers Computer a potential compensation has to be established.

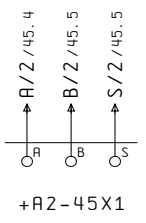
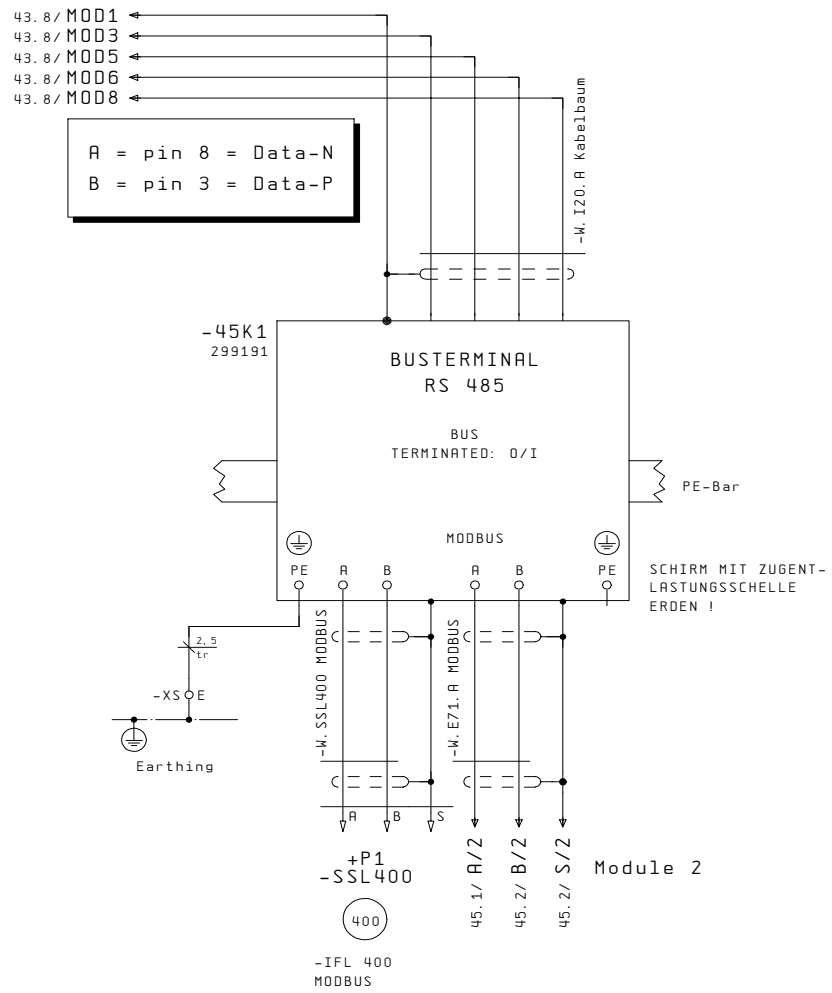

		Date	18.01.06	4 x JGS 320 GS-L.L		Jenbacher gas engines	MODBUS RTU		SD-Nr. Project	8662
		Desig.	Senfter M.	Nelson Gardens LFG			Suffix	J xxxx		
		Print	24.04.12	DIR: J:\EPLAN4\PLANLAGE\NXXX\N7XX\JN795.P			Wiring diagram	J N795 + R1 / 45		
Modific.	Date	Name	Check	Pieschnik A.	DIR: J:\EPLAN4\PLANLAGE\NXXX\N7XX\JN795.P	KW 12 - 2012	EPLAN 5			

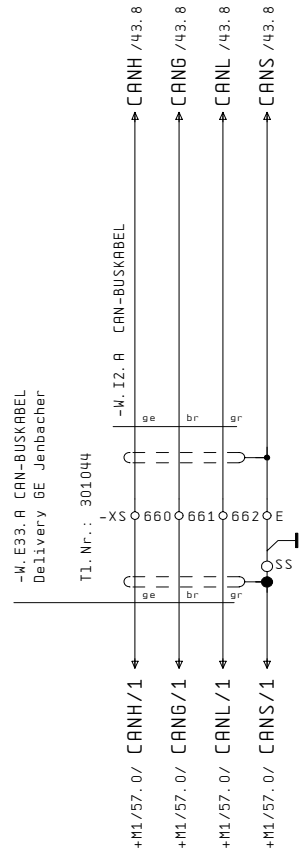

CAN-Bus

		Date	18.01.06	4 x JGS 320 GS-L.L	 Jenbacher gas engines	CAN-Bus	SD-Nr. Project	8662
		Desig.	Senfter M.	Nelson Gardens LFG			Suffix	J xxxx
		Print	24.04.12				Wiring diagram	J N795 + R1 / 46
Modific.	Date	Name	Check	Pieschnik A.	DIR: J:\EPLAN4\PARANL\BEN\WXXX\N7XX\JN795.P	KW 12 - 2012	EPLAN 5	

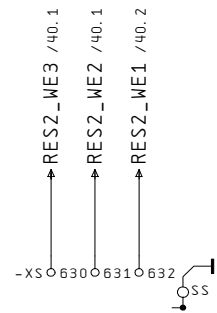

Spare

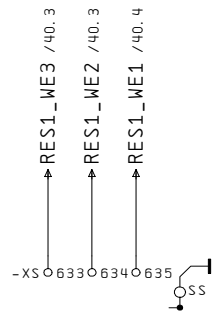

Spare

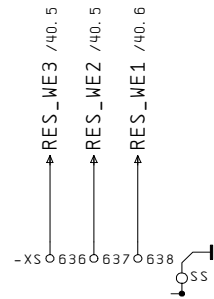

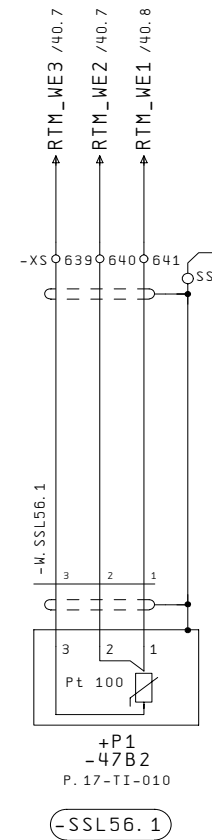

Spare

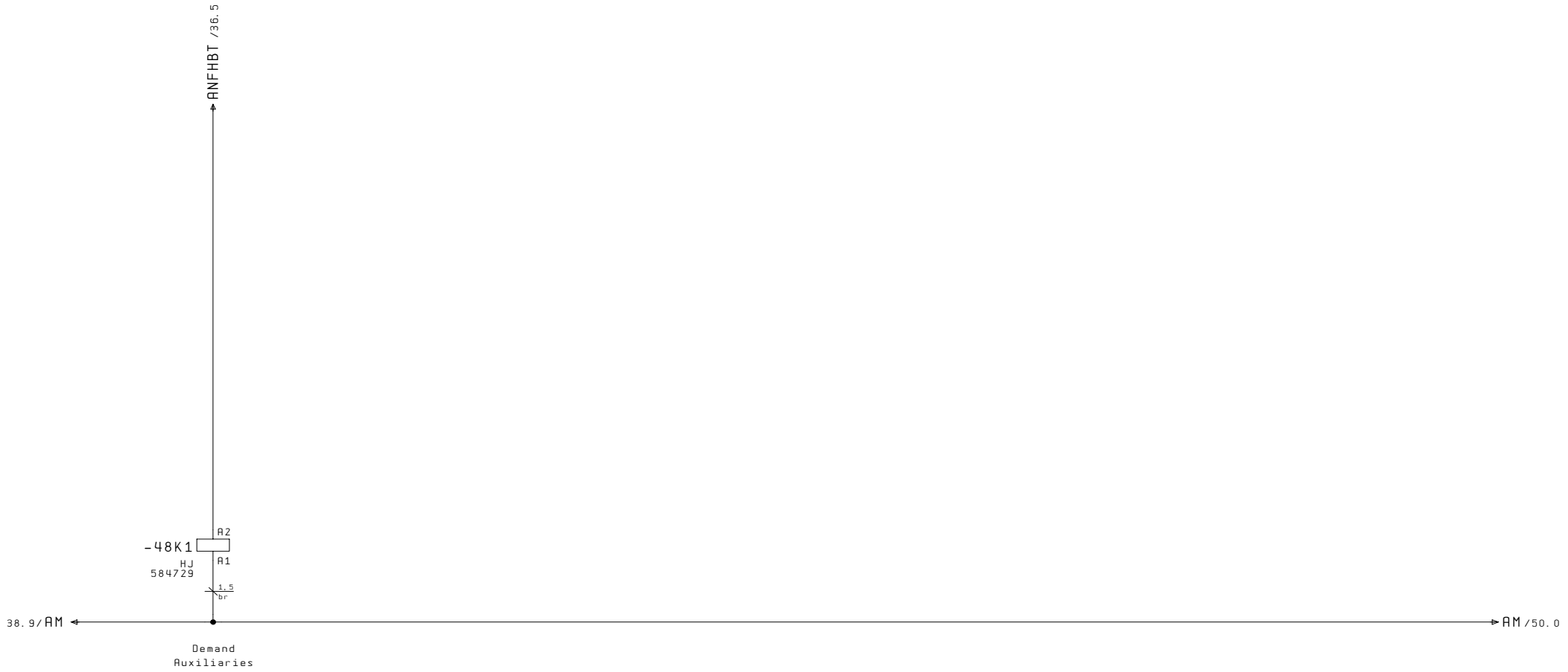

-IFL 56.1
Room temperature

		Date	18.01.06	4 x JGS 320 GS-L.L	 Jenbacher gas engines	Temperature sensor	SD-Nr.	8662
		Desig.	Senfter M.	Nelson Gardens LFG			Suffix	J xxxx
		Print	24.04.12				Wiring diagram	J N795 + R1 / 47
Modific.	Date	Name	Check	Pieschnik A.	DIR: J:\EPLAN4\VP\ANL\BEN\WXXX\N7XX\JN795.P	KW 12 - 2012	EPLAN 5	



		Date	18.01.06	4 x JGS 320 GS-L.L	 Jenbacher gas engines	Control Auxiliaries	SD-Nr. Project	8662
		Desig.	Senfter M.	Nelson Gardens LFG			Suffix	J xxxx
		Print	24.04.12				Wiring diagram	J N795 + R1 / 48
Modific.	Date	Name	Check	Pieschnik A.	DIR: J:\EPLAN4\P\ANL\GEN\XXXX\N7XX\JN795.P	KW 12 - 2012	EPLAN 5	

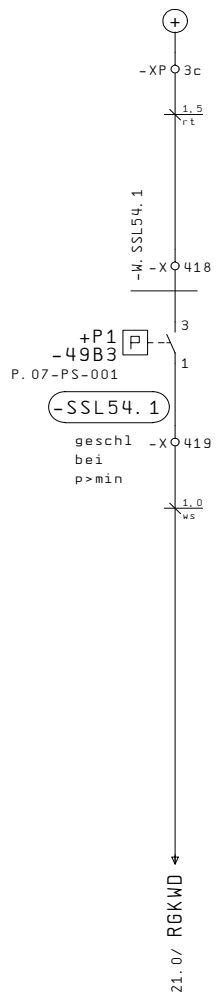

-IFL 54.1
Pressure low: Inter cooling water

		Date	18.01.06	4 x JGS 320 GS-L.L	 Jenbacher gas engines	Cooling circuit / Fuel mixture circuit	SD-Nr. Project	8662
		Desig.	Senfter M.	Nelson Gardens LFG			Suffix	J xxxx
		Print	24.04.12				Wiring diagram	J N795 + R1 / 49
Modific.	Date	Name	Check	Pieschnik A.	DIR: J:\EPLAN4\PARANLAGEN\XXXX\N7XX\JN795.P	KW 12 - 2012	EPLAN 5	

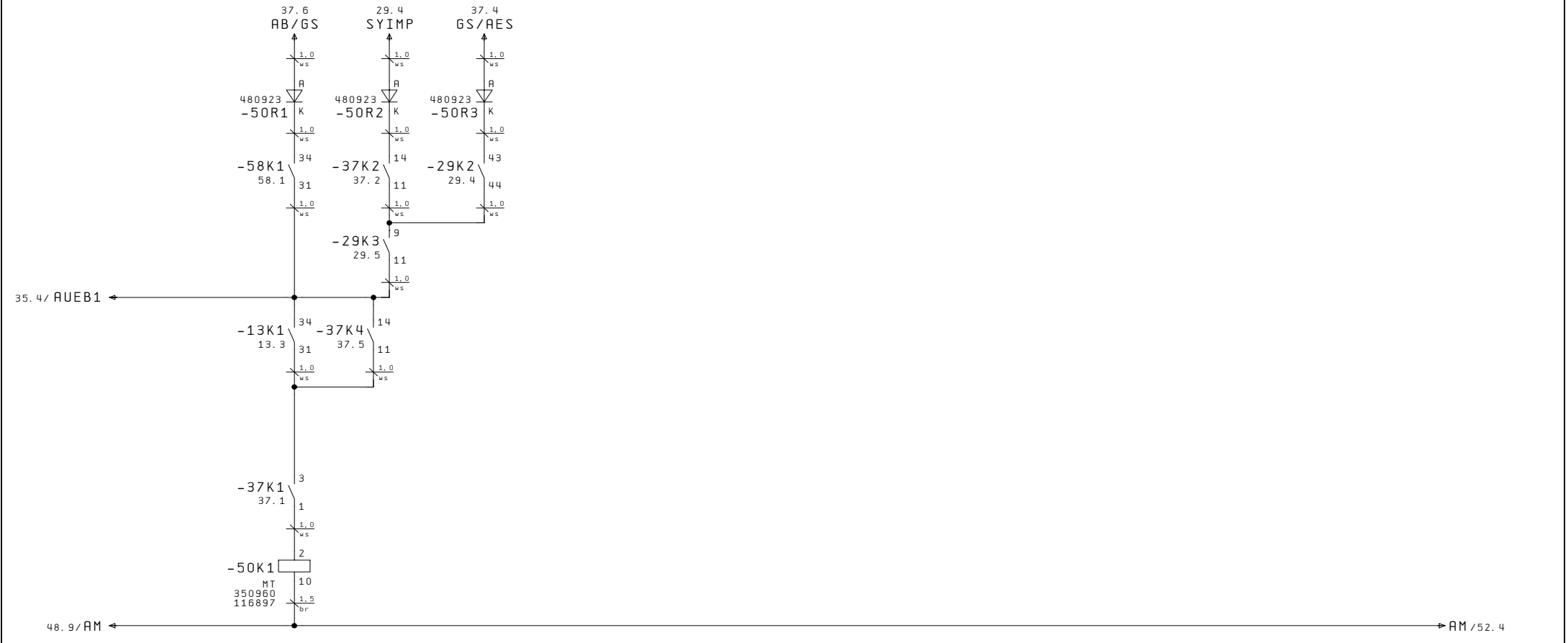

Command:
Generator circuit breaker: on/off

51.3 $\frac{1}{5}$ $\frac{3}{6}$
51.5 $\frac{5}{8}$ $\frac{6}{11}$
51.2 $\frac{8}{11}$

		Date	18.01.06	4 x JGS 320 GS-L.L	 Jenbacher gas engines	Control Generator circuit breaker	SD-Nr. Project	8662
		Desig.	Senfter M.	Nelson Gardens LFG		Suffix	J xxxx	
		Print	24.04.12			Wiring diagram	J N795 + R1 / 50	
Modific.	Date	Name	Check	Pieschnik A.	DIR: J:\EPLAN\4P\ANL\BEN\WXXX\N7XX\JN795.P	KW 12 - 2012	EPLAN 5	

Relay: Monitoring GCB

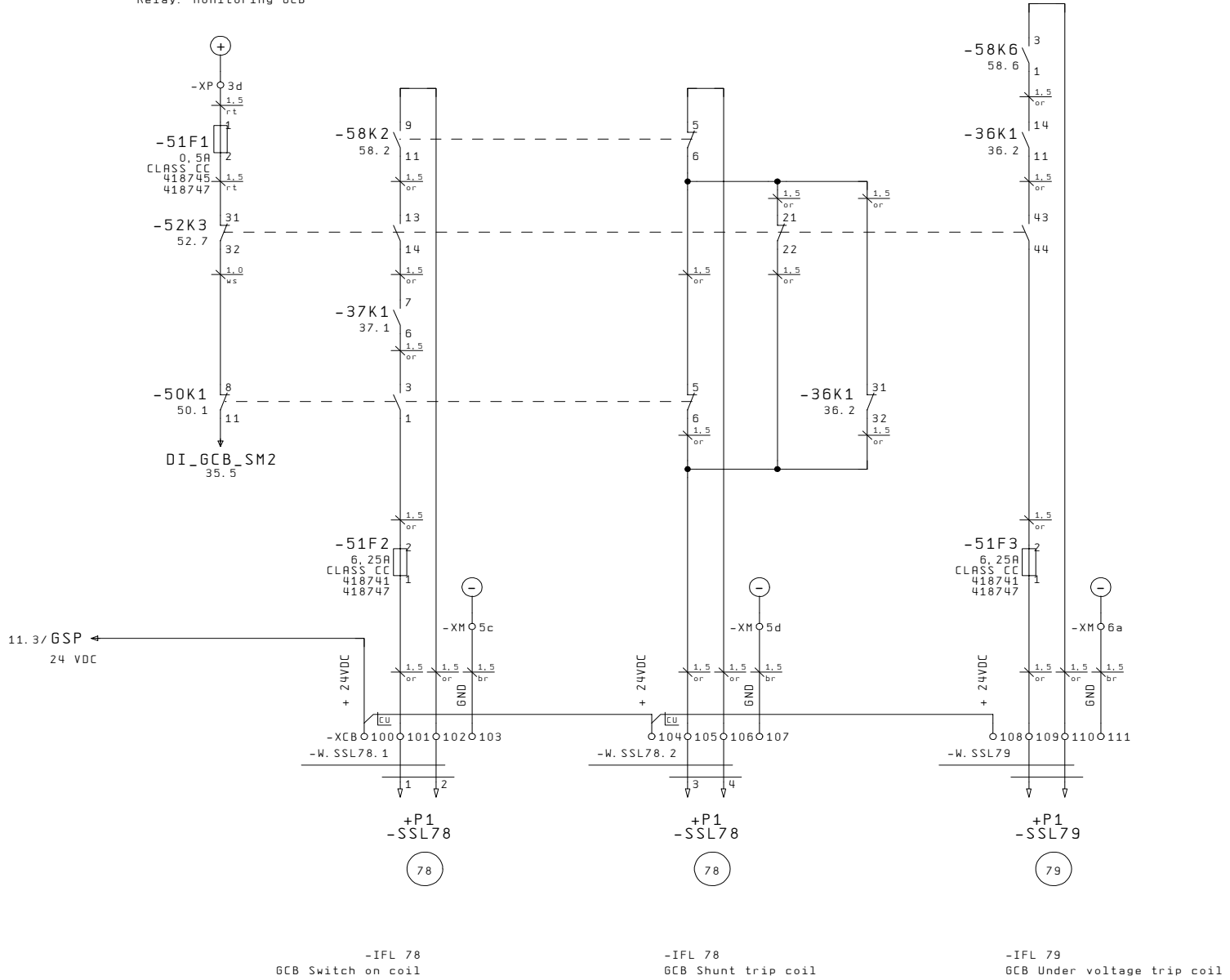

		Date	18.01.06	4 x JGS 320 GS-L.L		Jenbacher gas engines	Control Generator circuit breaker		SD-Nr. Project	8662
		Desig.	Senfter M.	Nelson Gardens LFG			Suffix	J xxxx		
		Print	24.04.12				Wiring diagram	J N795 + R1 / 51		
Modific.	Date	Name	Check	Pieschnik A.	DIR: J:\EPLAN4\VP\ANL\BEN\WXXX\N7XX\JN795.P	KW 12 - 2012	EPLAN 5			

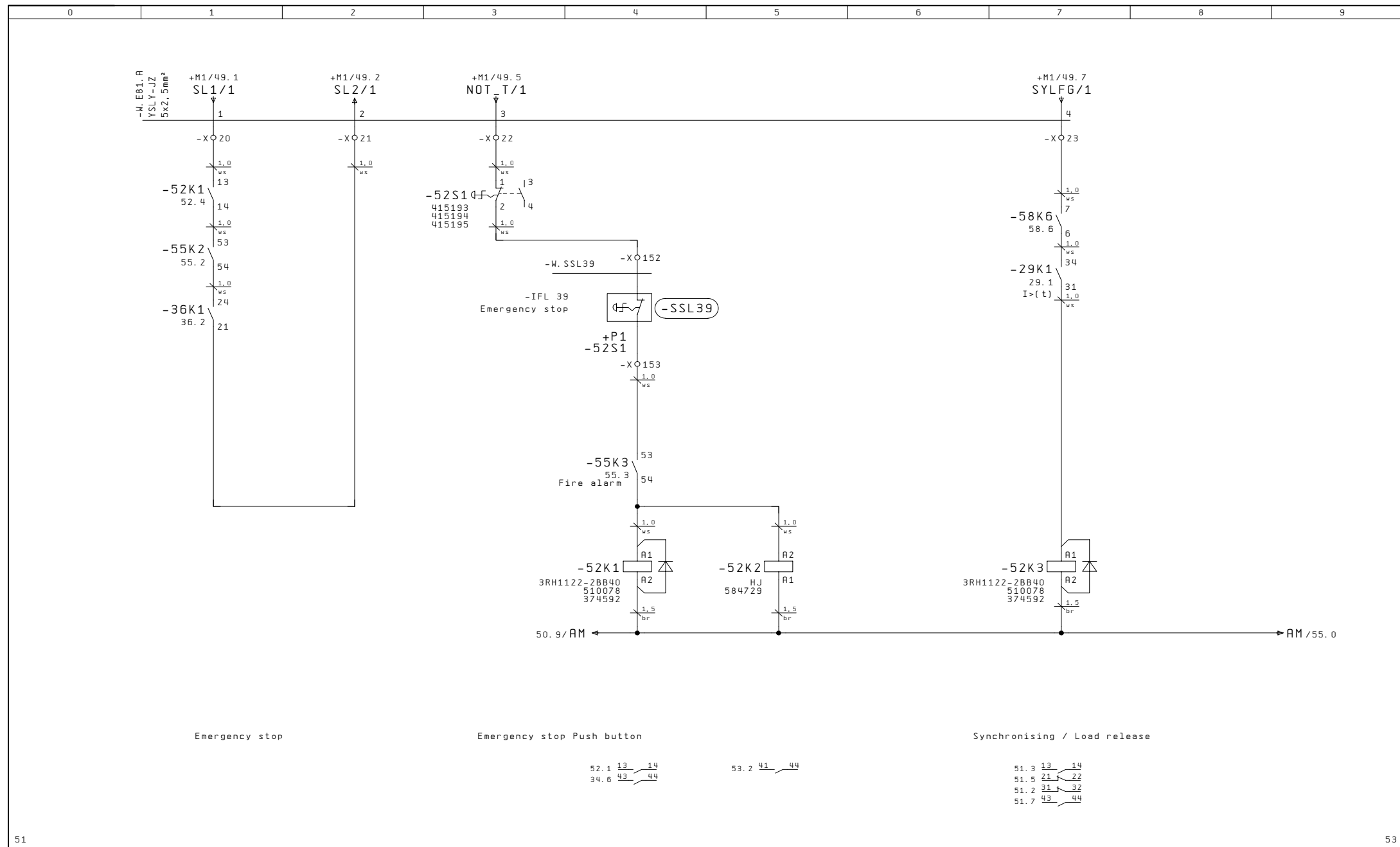

		Date	18.01.06	4 x JGS 320 GS-L.L	 Jenbacher gas engines	Emergency stop	SD-Nr. Project	8662
		Desig.	Senfter M.	Nelson Gardens LFG		Suffix	J xxxx	
		Print	24.04.12			Wiring diagram	J N795 + A1 / 52	
Modific.	Date	Name	Check	Pieschnik A.	DIR: J:\EPLAN4\VP\ANL\BEN\WXXX\N7XX\JN795.P	KW 12 - 2012	EPLAN 5	

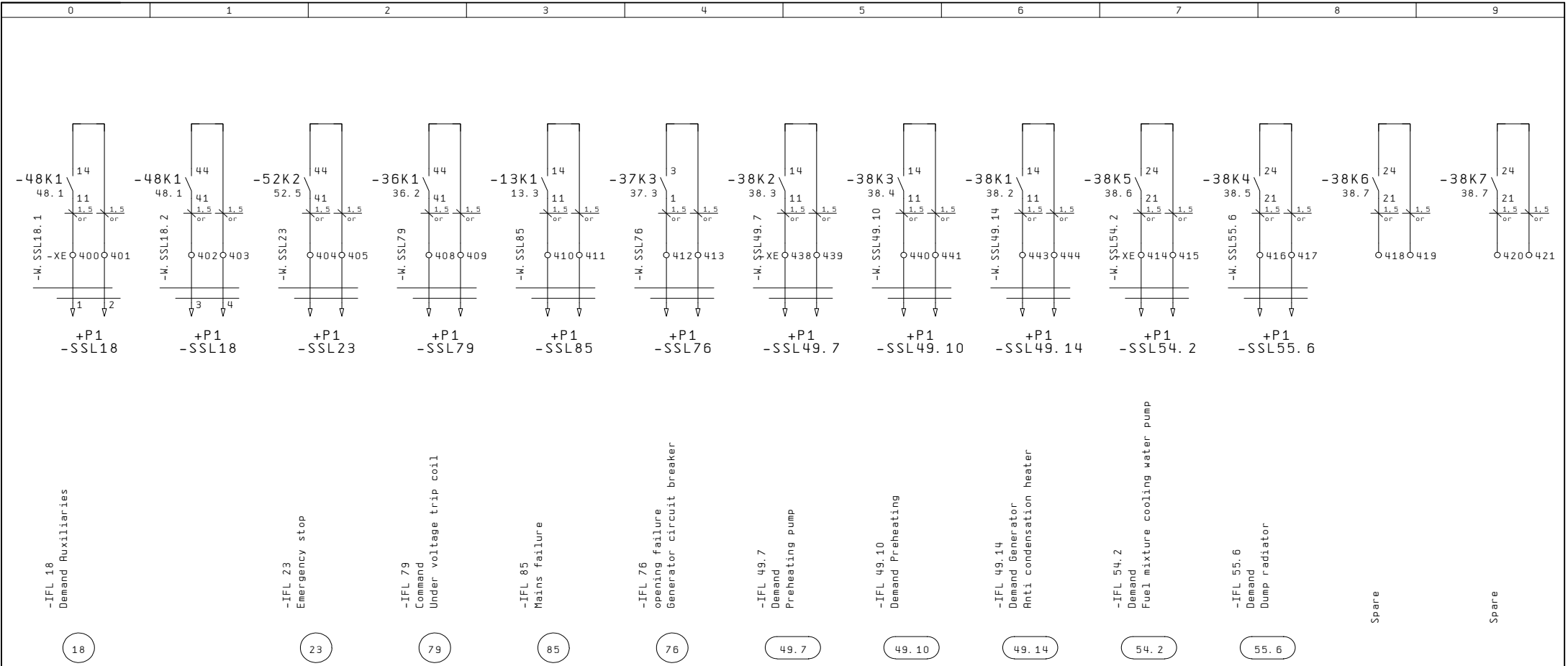

high. Contact load: 24VDC, 5A
230VAC, 5A

Date		18.01.06		4 x JGS 320 GS-L.L		 Jenbacher gas engines	Interfaces: Jenbacher --> Customer		SD-Nr. Project		8662	
Desig.		Senfter M.		Nelson Gardens LFG			Suffix		J xxxx			
Print		24.04.12		DIR: J:\EPLAN4\VP\ANL\BEN\WXXX\N7XX\N795.P			Wiring diagram		J N795 + R1 / 53			
Modific.	Date	Name	Check	Pieschnik A.		KW 12 - 2012	EPLAN 5					

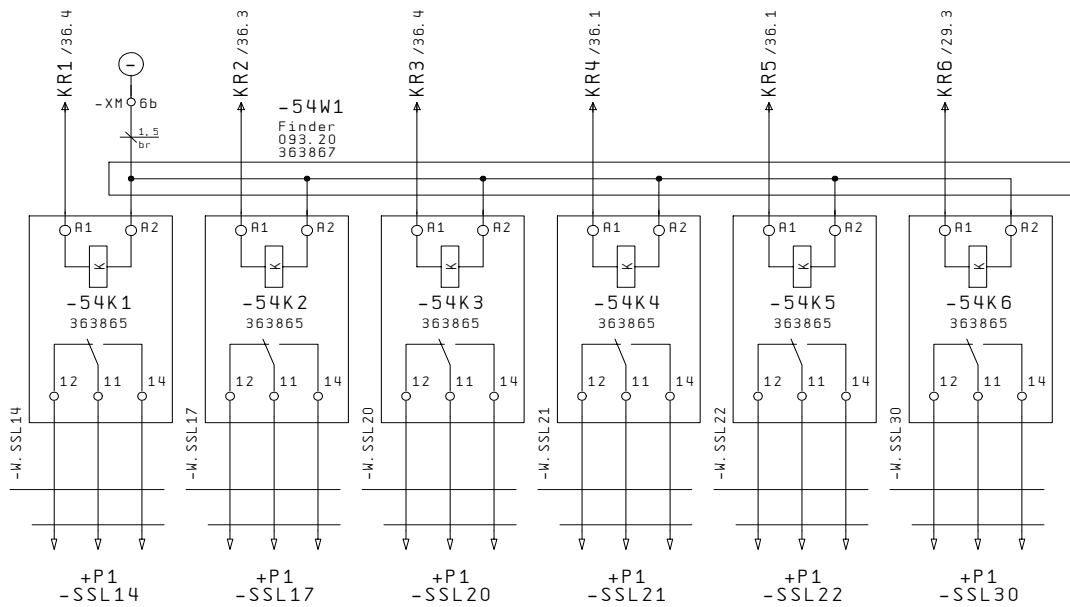

high. Contact load: 24VDC, 50mA

-IFL 14
ready for Automatic demand

14

-IFL 17
Module demanded

17

-IFL 20
Operation / Engine runs

20

-IFL 21
General alarm shut down

21

-IFL 22
General alarm warn

22

-IFL 30
Generator Energy

30

		Date	18.01.06	4 x JGS 320 GS-L.L	 Jenbacher gas engines	Report signals	SD-Nr. Project	8662
		Desig.	Senfter M.	Nelson Gardens LFG		Suffix	J xxxx	
		Print	24.04.12			Wiring diagram	J N795 + R1 / 54	
Modific.	Date	Name	Check	Pieschnik A.	DIR: J:\EPLAN4\VP\ANL\BEN\WXXX\N7XX\JN795.P	KW 12 - 2012	EPLAN 5	



-IFL 40.1
Gas prealarm

-IFL 40.2
Gas alarm

-IFL 41
Fire alarm

32. 7 13 14

32. 7 13 14
52. 1 53 54

32. 8 13 14
52. 4 53 54

		Date	18.01.06	4 x JGS 320 GS-L.L	 Jenbacher gas engines	Interfaces: Customer --> Jenbacher	SD-Nr. Project	8662	
		Desig.	Senfter M.	Nelson Gardens LFG		Suffix	J xxxx		
Modific.	Date	Name	Check	Pieschnik A.		DIR: J:\EPLAN4\VP\ANLAGEN\WXXX\N7XX\JN795.P	KW 12 - 2012	EPLAN 5	Wiring diagram

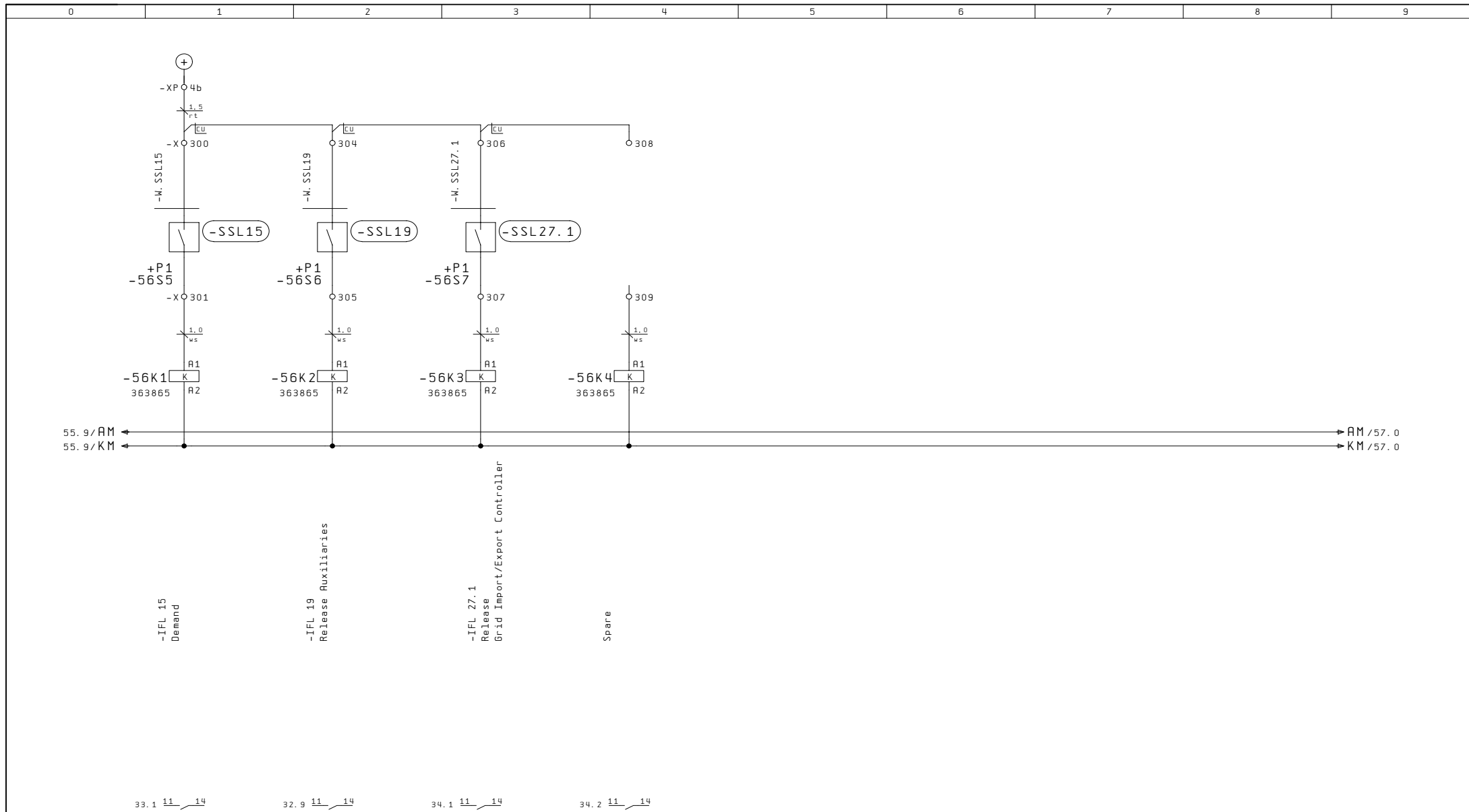

a		Date	18.01.06	4 x JGS 320 GS-L.L	 Jenbacher gas engines	Interfacés: Customer --> Jenbacher	SD-Nr. Project	8662
		Desig.	Senfter M.	Nelson Gardens LFG		Suffix	J xxxx	
		Print	24.04.12			Wiring diagram	J N795 + A1 / 56	
Modific.	Date	Name	Check	Pieschnik A.	DIR: J:\EPLAN4\VP\ANL\BEN\WXXX\N7XX\JN795.P	KW 12 - 2012	EPLAN 5	

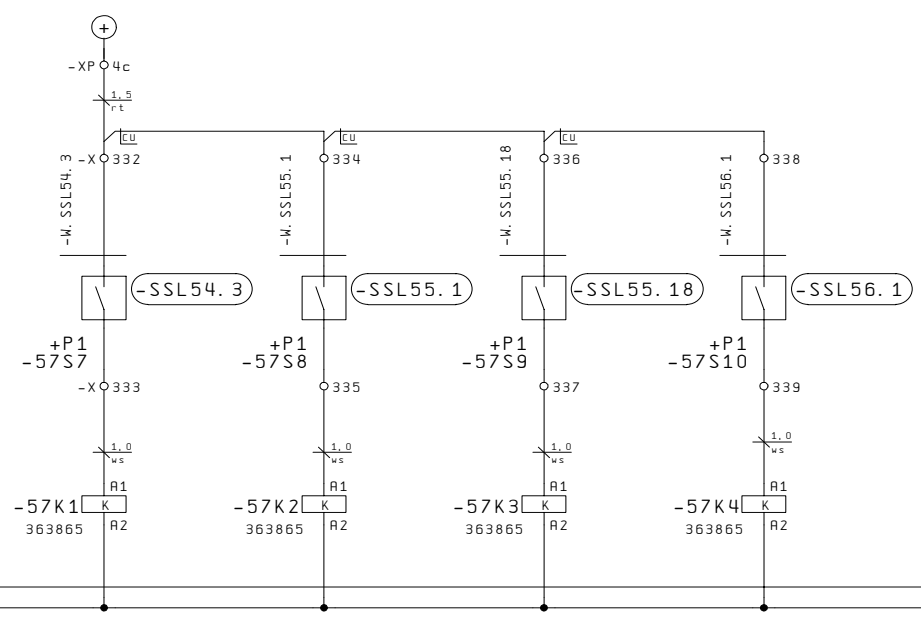

-IFL 54.3
Operation
Fuel mixture cooling
water pump

-IFL 55.1
Pressure:
Cooling circuit low.

-IFL 55.18
Failure Dump radiator

-IFL 56.1
Room temperature high

34.4 11 14 34.4 11 14 34.5 11 14 34.3 11 14

		Date	18.01.06	4 x JGS 320 GS-L.L	 Jenbacher gas engines	Interfaces: Customer --> Jenbacher	SD-Nr. Project	8662		
		Desig.	Senfter M.	Nelson Gardens LFG DIR: J:\EPLAN4\VP\ANL\BEN\WXXX\N7XX\JN795.P			KW 12 - 2012	EPLAN 5	Suffix	J xxxx
		Print	24.04.12							Wiring diagram
Modific.	Date	Name	Check	Pieschnik A.						

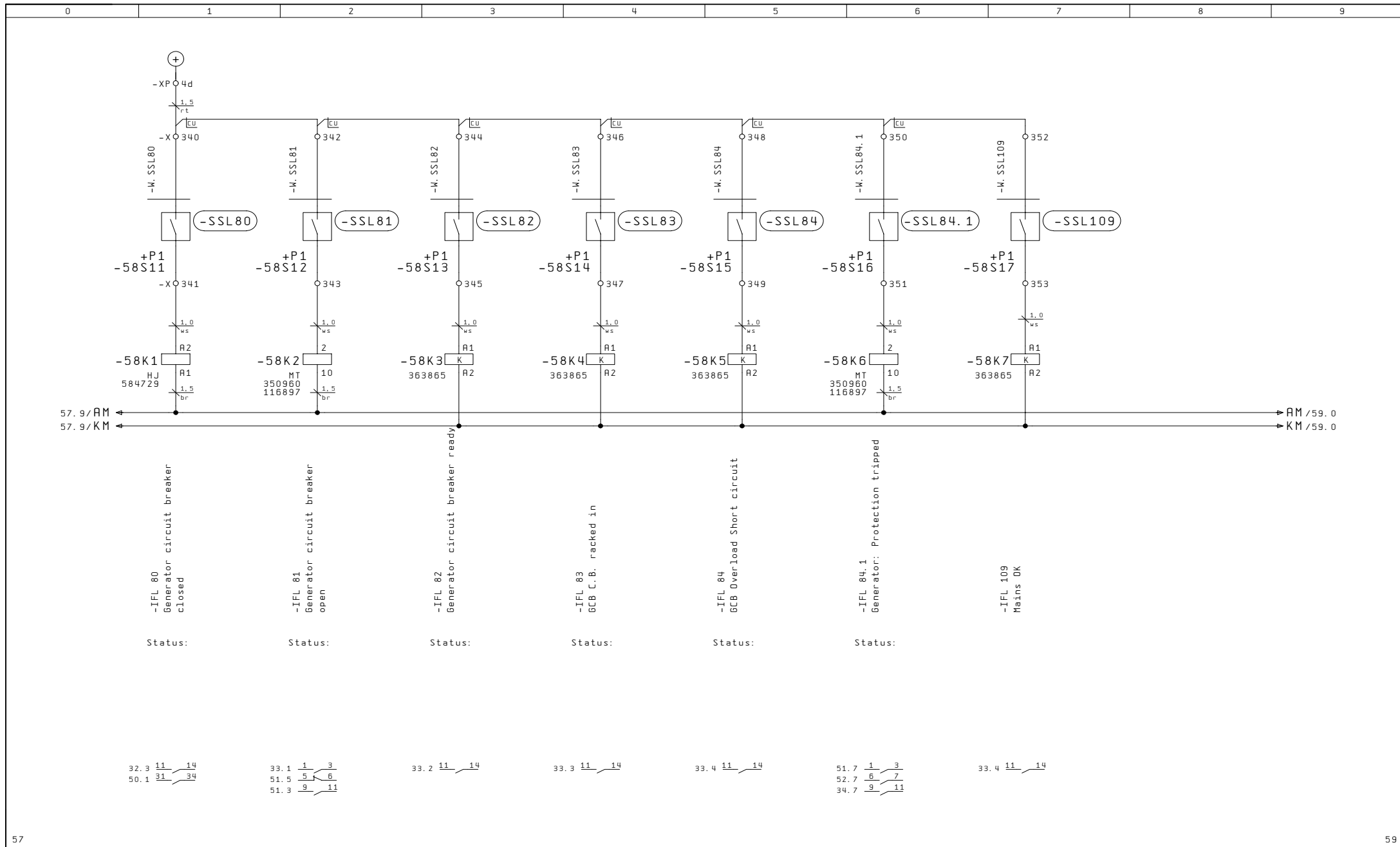

		Date	18.01.06	4 x JGS 320 GS-L.L		 Jenbacher gas engines	Interfaces Generator circuit breaker		SD-Nr. Project	8662
		Desig.	Senfter M.	Nelson Gardens LFG					Suffix	J xxxx
		Print	24.04.12						Wiring diagram	J N795 + A1 / 58
Modific.	Date	Name	Check	Pieschnik A.	DIR: J:\EPLAN4\VP\ANL\BEN\WXXX\N7XX\JN795.P	KW 12 - 2012	EPLAN 5			

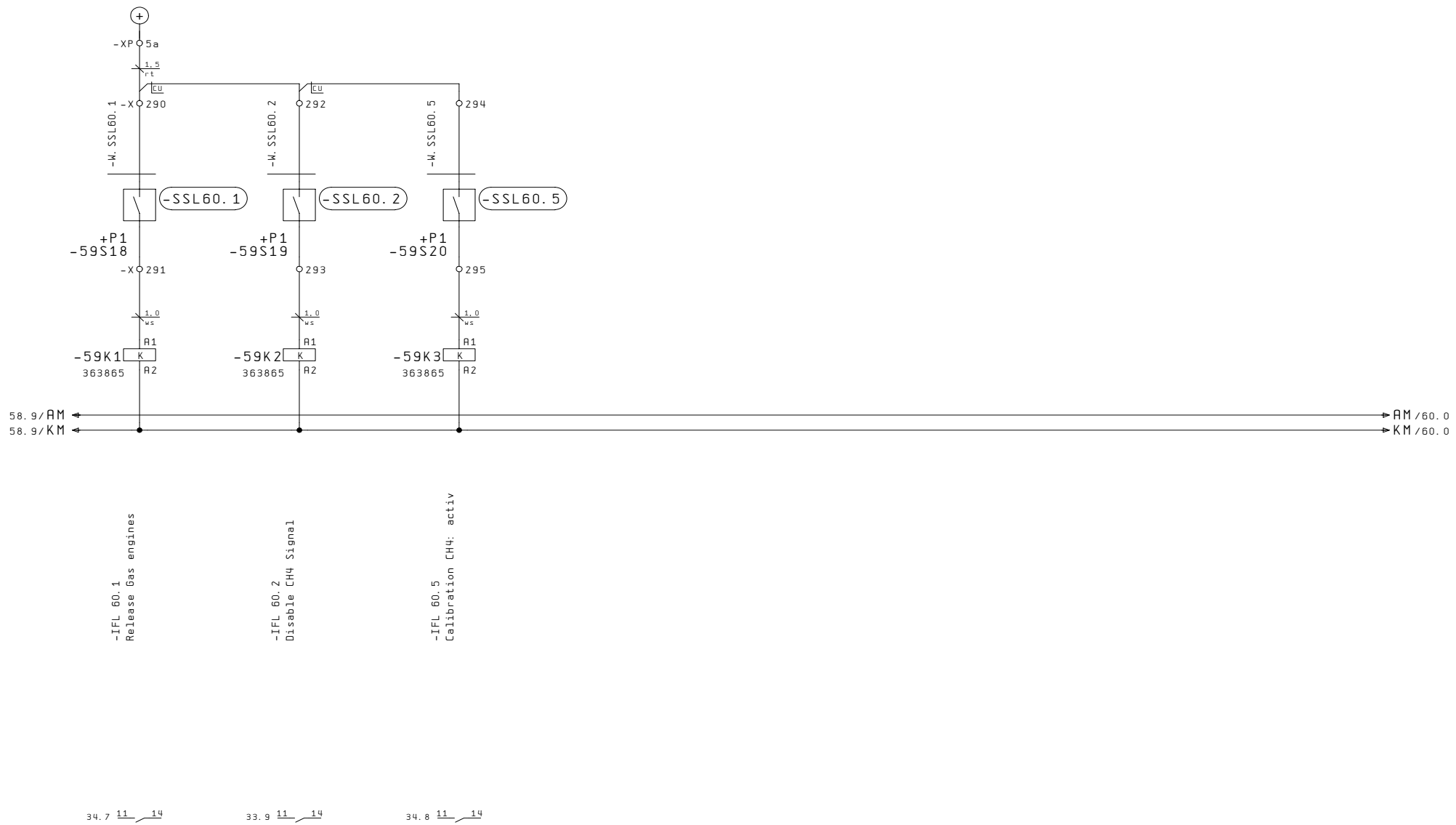

		Date	18.01.06	4 x JGS 320 GS-L.L	 Jenbacher gas engines	Interfaces: Customer --> Jenbacher	SD-Nr. Project	8662	
		Desig.	Senfter M.	Nelson Gardens LFG		Suffix	J xxxx		
Modific.	Date	Name	Check	Pieschnik A.		DIR: J:\EPLAN\4\VP\ANL\BEN\WXXX\N7XX\JN795.P	KW 12 - 2012	EPLAN 5	Wiring diagram

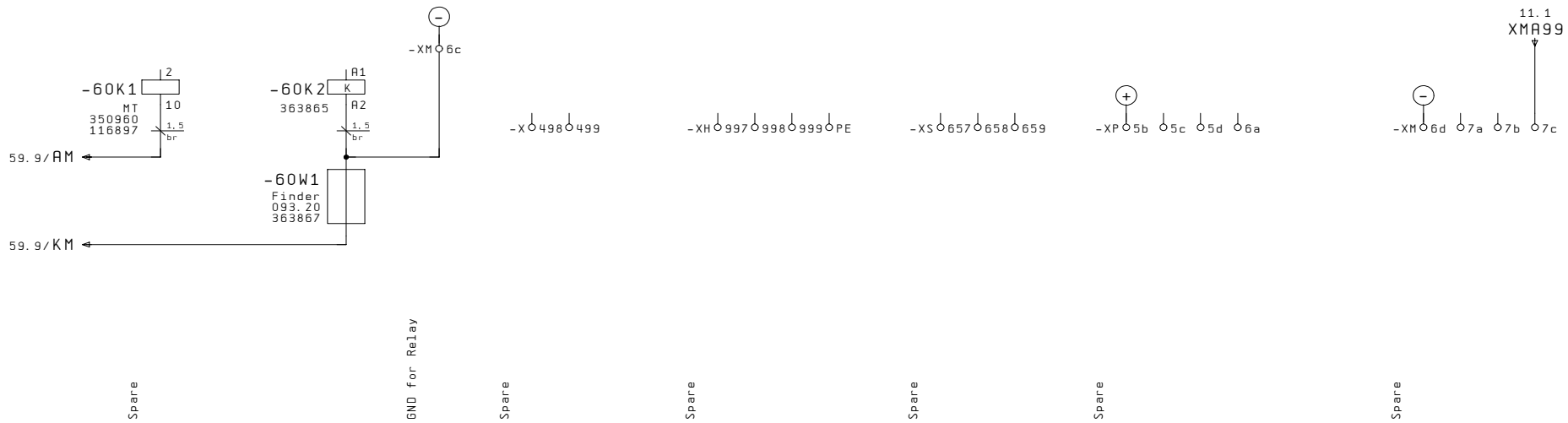

		Date	18.01.06	4 x JGS 320 GS-L.L	 Jenbacher gas engines	Spare	SD-Nr. Project	8662
		Desig.	Senfter M.	Nelson Gardens LFG			Suffix	J xxxx
		Print	24.04.12				Wiring diagram	J N795 + R1 / 60
Modific.	Date	Name	Check	Pieschnik A.	DIR: J:\EPLAN4\VP\ANL\BEN\WXXX\N7XX\JN795.P	KW 12 - 2012	EPLAN 5	

0	1	2	3	4	5	6	7	8	9
Terminal strip									
+A1-X									
Terminal									
Jumpers									
Device / Function									
Page									
	○ PE								
	○ E								
	○ 31								
	○ 31								
	○ 33								
	○ 33								
	○ 20								
	○ 21								
	○ 22								
	○ 23								
	○ 152								
	○ 153								
	○ 290								
	○ 291								
	○ 292								
	○ 293								
	○ 294								
	○ 295								
	○ 300								
	○ 301								
	○ 304								
	○ 305								
	○ 306								
	○ 307								
	○ 308								
	○ 309								
	○ 324								
	○ 325								
<p>gegn</p> <p>+A1-XH</p> <p>+M1-X</p> <p>+M1-M.E8.A YSLY-JZ 5x10mm²</p> <p>Module control panel</p> <p>3</p> <p>4</p> <p>1</p> <p>2</p> <p>+A1-M.E81.A YSLY-JZ 5x2.5mm²</p> <p>Emergency stop</p> <p>1</p> <p>2</p> <p>3</p> <p>4</p> <p>+A1-M.SSL39 2x -IFL 39</p> <p>Emergency stop</p> <p>1</p> <p>2</p> <p>+A1-M.SSL60.1 2x -IFL 60.1</p> <p>Release Gas engines</p> <p>1</p> <p>2</p> <p>+A1-M.SSL60.2 2x -IFL 60.2</p> <p>Disable CH4 Signal</p> <p>1</p> <p>2</p> <p>+A1-M.SSL60.5 2x -IFL 60.5</p> <p>Calibration CH4: activ</p> <p>1</p> <p>2</p> <p>+A1-M.SSL15 2x -IFL 15</p> <p>Demand</p> <p>1</p> <p>2</p> <p>+A1-M.SSL19 2x -IFL 19</p> <p>Release Auxiliaries</p> <p>1</p> <p>2</p> <p>+A1-M.SSL27.1 2x -IFL 27.1</p> <p>Release Grid Import/Export Controller</p> <p>1</p> <p>2</p> <p>+A1-M.SSL40.1 2x -IFL 40.1</p> <p>Gas prealarm</p> <p>1</p> <p>2</p>									
<p>Grounding</p> <p>Earthing</p> <p>Module interface</p> <p>=</p> <p>=</p> <p>=</p> <p>Emergency stop</p> <p>=</p> <p>Emergency stop Push button</p> <p>Synchronising / Load release</p> <p>-IFL 39 Emergency stop</p> <p>=</p> <p>-IFL 60.1 Release Gas engines</p> <p>=</p> <p>-IFL 60.2 Disable CH4 Signal</p> <p>=</p> <p>-IFL 60.5 Calibration CH4: activ</p> <p>=</p> <p>-IFL 15 Demand</p> <p>=</p> <p>-IFL 19 Release Auxiliaries</p> <p>=</p> <p>-IFL 27.1 Release Grid Import/Export Controller</p> <p>=</p> <p>Spare</p> <p>=</p> <p>-IFL 40.1 Gas prealarm</p> <p>=</p>									
<p>/20.0</p> <p>/11.0</p> <p>/11.1</p> <p>/11.1</p> <p>/11.1</p> <p>/11.1</p> <p>/52.1</p> <p>/52.2</p> <p>/52.3</p> <p>/52.7</p> <p>/52.4</p> <p>/52.4</p> <p>/59.1</p> <p>/59.1</p> <p>/59.2</p> <p>/59.2</p> <p>/59.3</p> <p>/59.3</p> <p>/56.1</p> <p>/56.1</p> <p>/56.2</p> <p>/56.2</p> <p>/56.3</p> <p>/56.3</p> <p>/56.4</p> <p>/56.4</p> <p>/55.1</p> <p>/55.1</p>									

Modific.	Date	Name	Check	Pieschnick A.	DIR: J:\EPLAN4\VP\ANL\RGEB\WXXX\N7XX\JN795.P	 Jenbacher gas engines	Terminals general +A1	SO-Nr.	8662	
					Project				Suffix	
									Wiring diagram	J N795 +A1 / 61

Terminal	Jumpers	Terminal strip	Page
		+A1-X	
		Device / Function	Page
		-IFL 40.2 Gas alarm	/55.2
		=	/55.2
		-IFL 41 Fire alarm	/55.3
		=	/55.3
		-IFL 54.3 Operation Fuel mixture cooling water pump	/57.2
		=	/57.2
		-IFL 55.1 Pressure: Cooling circuit low.	/57.3
		=	/57.3
		-IFL 55.18 Failure Dump radiator	/57.4
		=	/57.4
		-IFL 56.1 Room temperature high	/57.5
		=	/57.5
		-IFL 80 Generator circuit breaker closed	/58.1
		=	/58.1
		-IFL 81 Generator circuit breaker open	/58.2
		=	/58.2
		-IFL 82 Generator circuit breaker ready	/58.3
		=	/58.3
		-IFL 83 GCB C.B. racked in	/58.4
		=	/58.4
		-IFL 84 GCB Overload Short circuit	/58.5
		=	/58.5
		-IFL 84.1 Generator: Protection tripped	/58.6
		=	/58.6

61		63						
Date	18.01.06	4 x JGS 320 GS-L.L	 Jenbacher gas engines					
Desig.	Senfter M.	Nelson Gardens LFG						
Print	24.04.12							
Modific.	Date	Name	Check	Pieschnik A.	DIR: J:\EPLAN4\VP\ANL\BEN\WXXX\N7XX\JN795.P	EPLAN 5	Terminals general +A1	SO-Nr. Project 8662 Suffix Wiring diagram J N795 + A1 / 62

Terminal	Device / Function	Page
O- 100	+ 24VDC	/51.3
O- 101	-IFL 78 GCB Switch on coil	/51.3
O- 102	=	/51.4
O- 103	GND	/51.4
O- 104	+ 24VDC	/51.5
O- 105	-IFL 78 GCB Shunt trip coil	/51.5
O- 106	=	/51.5
O- 107	GND	/51.5
O- 108	+ 24VDC	/51.7
O- 109	-IFL 79 GCB Under voltage trip coil	/51.7
O- 110	=	/51.7
O- 111	GND	/51.7

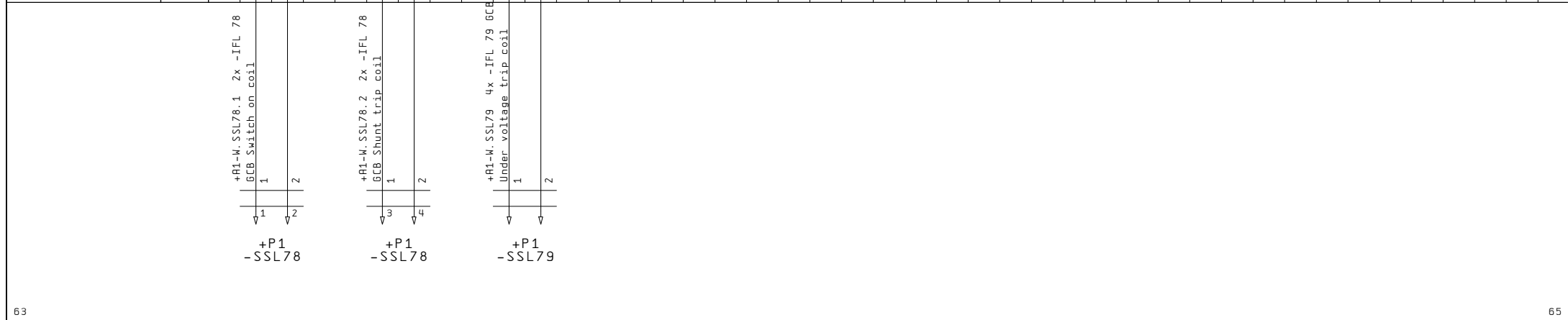

0	1	2	3	4	5	6	7	8	9
Terminal strip	+R1-XH								
Jumpers									
Terminal									
	Device / Function	Page							
	Spare	/60.4							
	=	/60.4							
	=	/60.4							
	=	/60.4							
	Panel fan	/11.5							
	Generator voltage	/31.1							
	=	/31.2							
	=	/31.3							
	=	/31.3							
	Grounding	/20.0							
	Equipotential bonding Module interface	/20.1							
	-IFL 3 Equipotential bonding	/20.1							

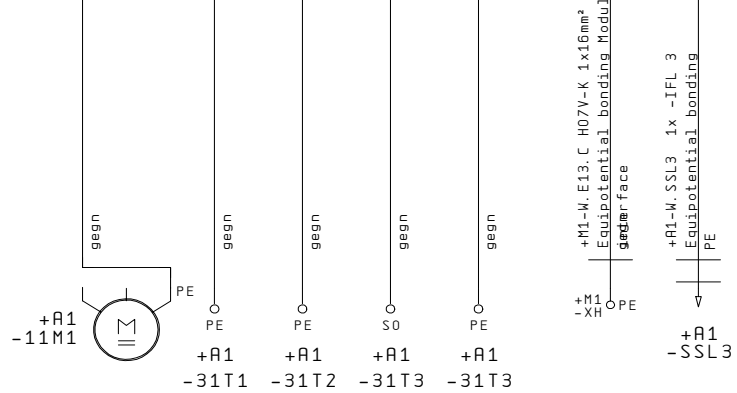

Modific.	Date	Name	Check	Pieschnik A.	DIR: J:\EPLAN4\VP\ANL\AGEN\WXXX\N7XX\JN795.P	 Jenbacher gas engines	Terminals Auxiliaries +R1	SO-Nr. Project	8662
								Suffix	
								Wiring diagram	J N795 +R1 / 67

Terminal strip	Device / Function	Page
+R1-XM	Module interface	/11.1
	Control	/11.2
	Panel fan	/11.5
	Visualisation	/11.5
	Data communication	/11.9
	Mains monitoring device	/13.2
	Resistor - Digital Input	/21.0
	Supply PLC	/28.4
	=	/28.6
	Supply: Digital Outputs MMUSYNC	/29.8
	GND for Relay	/36.6
	-IFL 29 Generator active power	/41.1
	=	/41.2
	Spare	/41.3
=	/41.4	

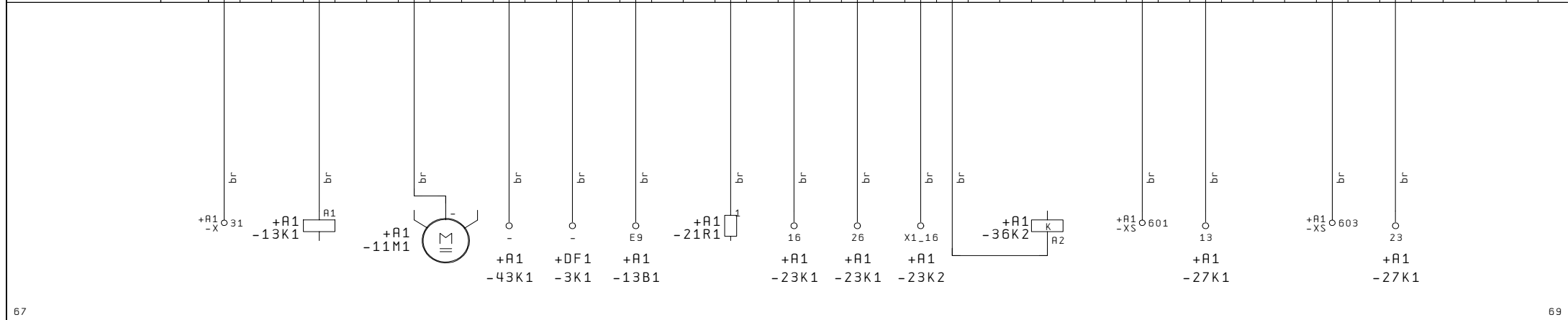

67		69	
Modific.	Date	Name	Check
		Pieschnik A.	
Date		18.01.06	
Design		Senfter M.	
Print		24.04.12	
4 x JGS 320 GS-L.L		Nelson Gardens LFG	
DIR: J:\EPLAN4\VP\ANL\BEN\WXXX\N7X\JN795.P		EPLAN 5	
Jenbacher gas engines		Terminals Base - 0VDC	
SD-Nr. Project		8662	
Suffix			
Wiring diagram		J N795 +R1 / 68	

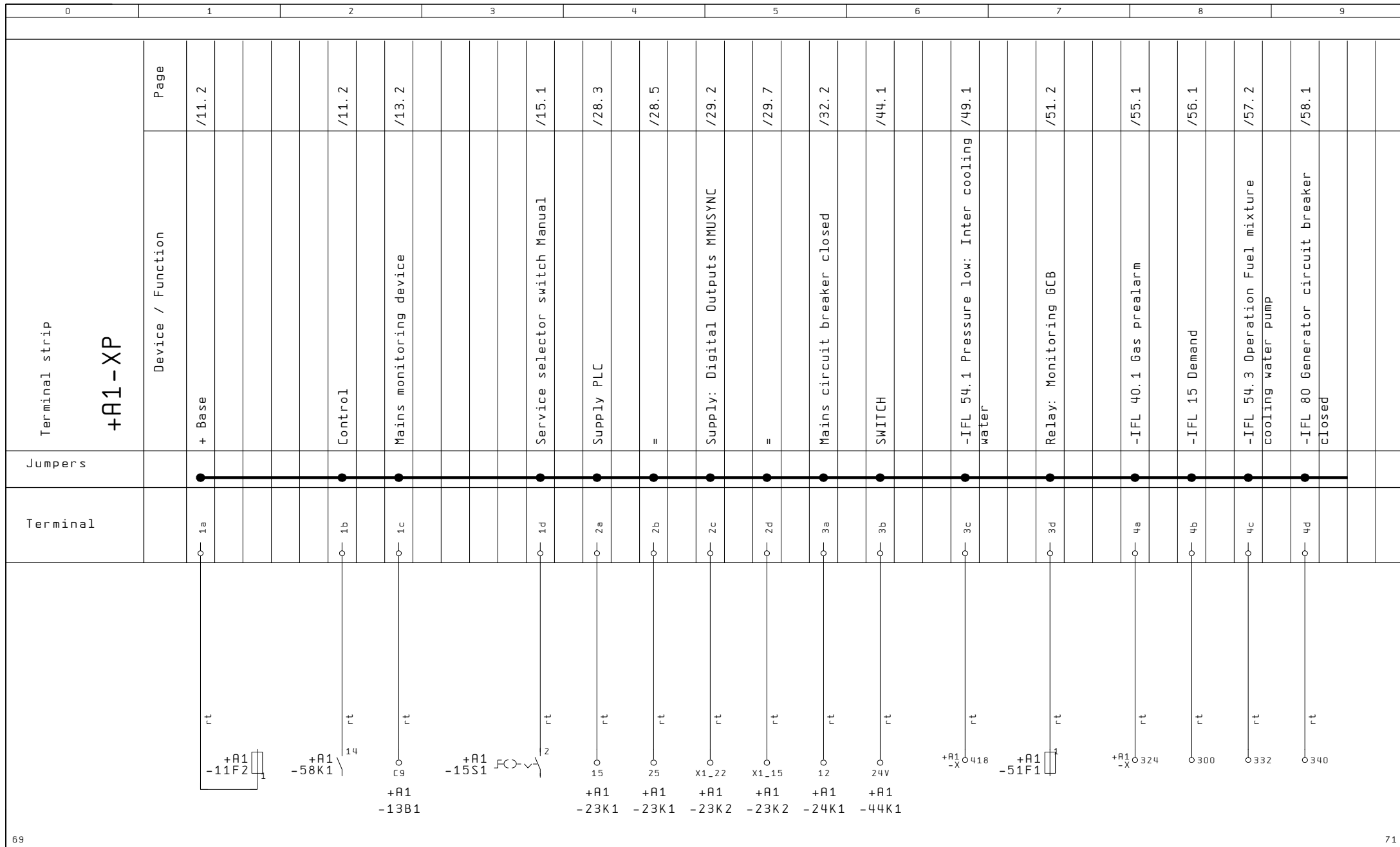

Modific.	Date	Name	Check	Pieschnik A.	DIR: J:\EPLAN4\VP\ANL\GEN\WXXX\N7XX\JN795.P	 Jenbacher gas engines	Terminals Base +24VDC	50-Nr. Project	8662
					Suffix				
					Wiring diagram			J N795 + A1 / 70	

0	1	2	3	4	5	6	7	8	9
Terminal strip +R1-XP	Page	/59.1							
	Device / Function	-IFL 60.1 Release Gas engines							
		Spare							
		=							
		=							
		=							
Jumpers									
Terminal	O- 5a	O- 5b	O- 5c	O- 5d	O- 6a				

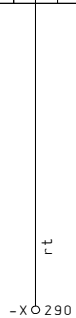

		Date	18.01.06	4 x JGS 320 GS-L.L	Jenbacher gas engines	Terminals	SD-Nr. Project	8662
		Desig.	Senfter M.	Nelson Gardens LFG		Base +24VDC	Suffix	
		Print	24.04.12				Wiring diagram	J N795 + R1 / 71
Modific.	Date	Name	Check	Pieschnik A.	DIR: J:\EPLAN4\VP\ANL\GEN\WXXX\N7XX\JN795.P	EPLAN 5		

0	1	2	3	4	5	6	7	8	9
Terminal strip	+A1-XS								
Jumpers	Device / Function								
Terminal	Page								
	○- 584	-IFL 61.2 Content:CH4 Collect line							/39.4
	○- 585	=							/39.4
	○- 587	=							/39.6
	○- 588	=							/39.6
	○- 600	-IFL 29 Generator active power							/41.1
	○- 601	=							/41.1
	○- 602	Spare							/41.3
	○- 603	=							/41.3
	○- 604	=							/41.5
	○- 605	=							/41.5
	○- 610	-IFL 28 External Set point power							/39.0
	○- 611	=							/39.0
	○- 612	-IFL27 External Decrease load							/39.2
	○- 613	=							/39.2
	○- 630	Spare							/47.3
	○- 631	=							/47.3
	○- 632	=							/47.3
	○- 633	=							/47.4
	○- 634	=							/47.4
	○- 635	=							/47.5
	○- 636	=							/47.6
	○- 637	=							/47.6
	○- 638	=							/47.6
	○- 639	-IFL 56.1 Room temperature							/47.7
	○- 640	=							/47.8
	○- 641	=							/47.8
	○- 657	Spare							/60.5
	○- 658	=							/60.5
	○- 659	=							/60.5
	○- 660	CAN-Bus							/46.2
	○- 661	=							/46.2
	○- 662	=							/46.2
	○- E	=							/46.2
	○- E	Earthing							/45.3

71		Date 18.01.06		4 x JGS 320 GS-L.L		 Jenbacher gas engines	SD-Nr. Project 8662		
		Desig. Senfter M.		Nelson Gardens LFG			Suffix		
		Print 24.04.12		DIR: J:\EPLAN4\VP\ANL\BEN\WXXX\N7XX\N795.P			Wiring diagram J N795 + A1 / 72		
Modific.	Date	Name	Check	Pieschnik A.		Terminals Shielded cable +A1		+DF1/1	



HERMES +DF1

Parameters for the operation
of GE Jenbacher Engines
acc. TI.Nr.: 1100-0110

Modifications of Design
reserved.

All Cables between the
Switchboards and the Engine
have to be in flexible mode.

Protection against electric shocks hazard
earthing, equipotential bonding, has to be
provided by the Customer at installation
according to local Standards !
At staes of delivery the engine
is prepared for the protection by
automatic disconnection of supply
in TN-Systems according to
HD 60364-4-41 / IEC 60364-4-41.

 The Numbers in the circles are in
Relation with the Numbers in the
Interface-List J N795

This Wiring Diagram is designed with
a CAE-System.
Modifications will be occupied by
GE Jenbacher

+R1/72

2

		Date	18.01.06	4 x JGS 320 GS-L.L	 Jenbacher gas engines	HERMES +DF1	SD-Nr. Project	8662
		Desig.	Senfter M.	Nelson Gardens LFG			Suffix	J xxxx
		Print	24.04.12				DIR: J:\EPLAN4\VP\ANL\BEN\WXXX\N7XX\JN795.P	Wiring diagram
Modific.	Date	Name	Check	Pieschnik R.	KW 12 - 2012	EPLAN 5		

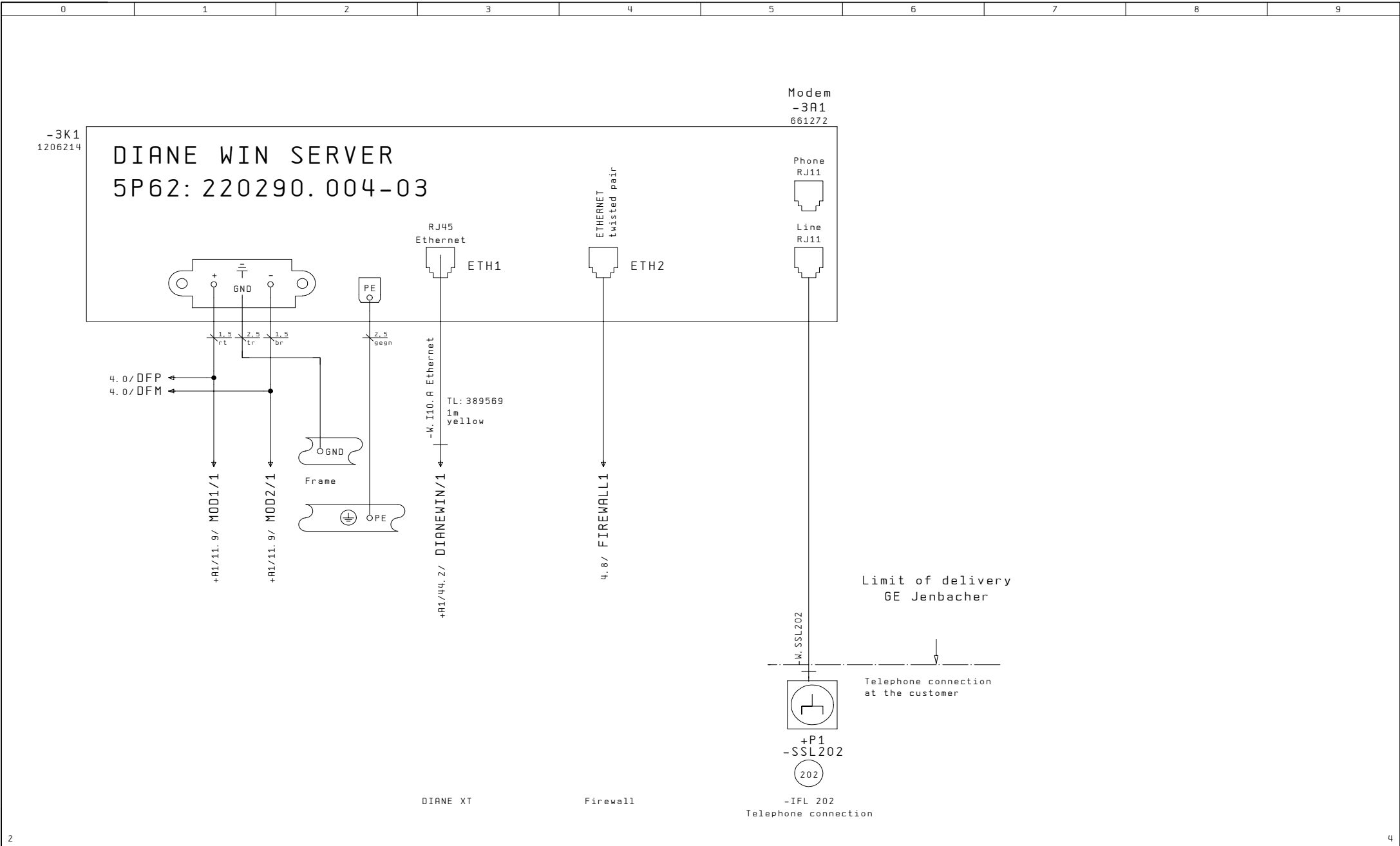

		Date	18.01.06	4 x JGS 320 GS-L.L	Jenbacher gas engines	DIANE WIN SERVER 1	SD-Nr. Project	8662
		Desig.	Senfter M.	Nelson Gardens LFG		ATOM	Suffix	J xxxx
		Print	24.04.12				Wiring diagram	J N795 + DF1 / 3
Modific.	Date	Name	Check	Pieschnik A.	DIR: J:\EPLAN4\VP\ANLAGEN\WXXX\N7XX\JN795.P	KW 12 - 2012	EPLAN 5	

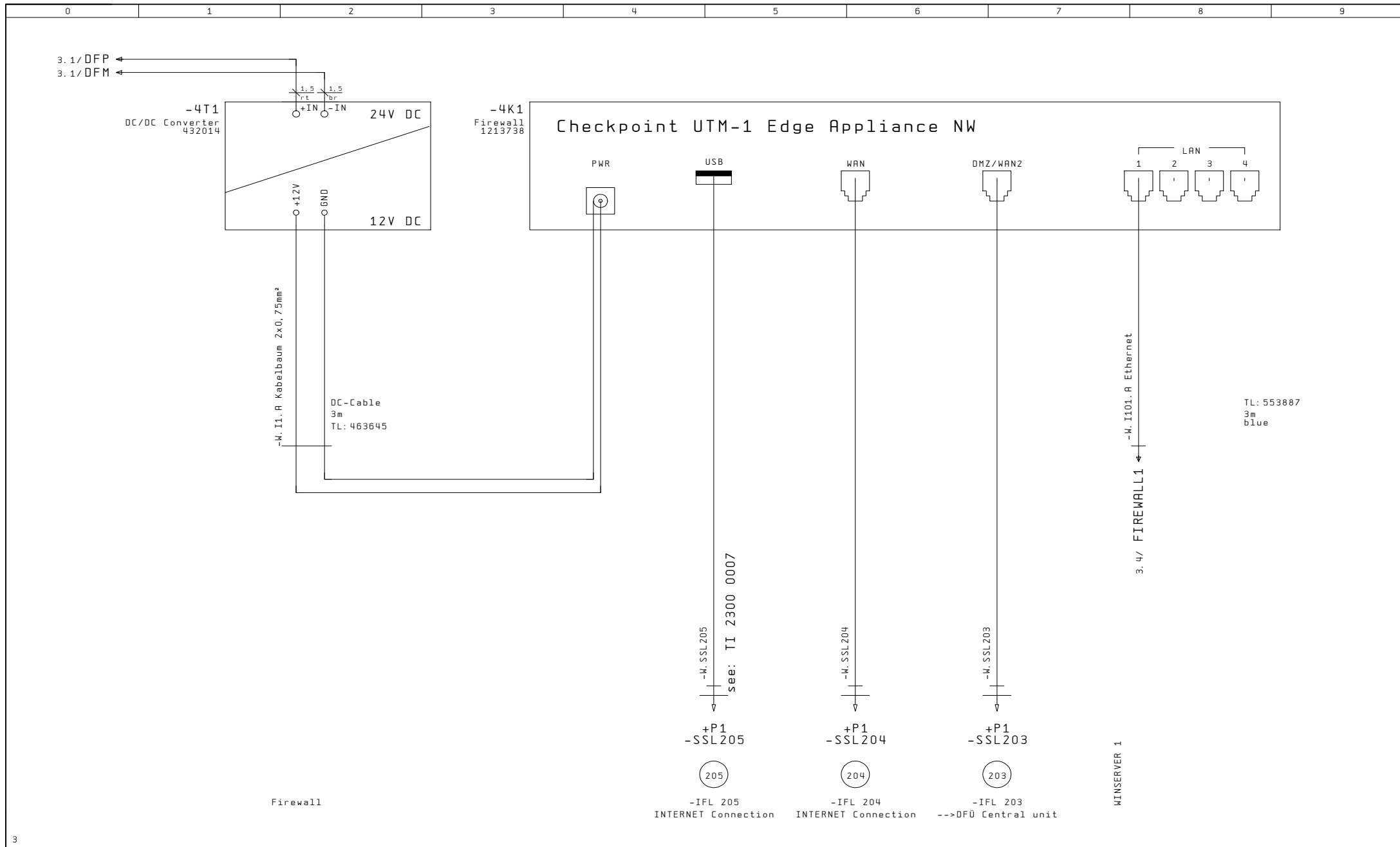

		Date	18.01.06	4 x JGS 320 GS-L.L	 Jenbacher gas engines	Firewall	SD-Nr. Project	8662
		Desig.	Senfter M.	Nelson Gardens LFG			Suffix	J xxxx
		Print	24.04.12				Wiring diagram	J N795 + DF1 / 4
Modific.	Date	Name	Check	Pieschnik A.	DIR: J:\EPLAN4\PROJEKTE\GEN\WXXX\N7XX\JN795.P	KW 12 - 2012	EPLAN 5	