



MRG3 – Generator protection with mains supervision, time overcurrent protection and earth current supervision

(September 2008)

Manual MRG3 (Revision New)

Woodward Governor Company reserves the right to update any portion of this publication at any time. Information provided by Woodward Governor Company is believed to be correct and reliable. However, no responsibility is assumed by Woodward Governor Company unless otherwise expressly undertaken.

© Woodward 1994-2008

Inhalt

1. Overview and Application	6
2. Features and Characteristics	7
3. Design	8
3.1 Connections	8
3.1.1 Connection Diagrams	8
3.1.2 Analog input circuits	13
3.1.3 Output relays	13
3.1.4 Blocking input	13
3.1.5 External reset input	13
3.1.6 Serial interface	13
3.1.7 Auxiliary voltage supply	13
3.1.8 Code plugs	14
3.1.9 Low/high range of the digital inputs	16
3.2 Front plates	17
3.3 LEDs	20
4. Working Principle	21
4.1 Analog circuits	21
4.2 Digital circuits	21
4.3 Voltage supervision	21
4.3.1 Selection of star or delta connection	22
4.4 Principle of frequency supervision	23
4.5 Mains decoupling	24
4.5.1 Measuring of frequency gradients	24
4.5.2 Vector surge supervision	25
4.5.3 Measuring principle of vector surge supervision	26
4.5.4 Voltage threshold value for frequency, df/dt and vector surge measuring	29
4.6 Over current- and short circuit supervision	29
4.7 Earth fault protection	30
4.7.1 Generator stator earth fault protection	30
4.7.2 System earth fault protection	30
4.7.3 Earth-fault directional feature	31
4.7.4 Residual voltage	33
4.7.5 Behavior of MRG3 under different operating conditions	33
4.7.6 Blocking function set in compliance with requirements	33
4.8 Fault recorder	34
5. Operation and Settings	36
5.1 Display	36
5.2 Setting procedure	40
5.3 Systemparameters	40
5.3.1 Y – Change-over switch	40
5.3.2 Display of measurement values as primary quantity	40
5.3.3 Setting of measured secondary values for the voltage transformers	40
5.3.4 Setting of the generator's nominal values	40
5.3.5 Voltage transformer connection for residual voltage measuring (3pha/e-n/1:1)	41
5.3.6 Nominal frequency	41
5.3.7 Selection between vector surge function or df/dt supervision	41
5.3.8 Display of the activation storage	41
5.3.9 Parameter changeover switch/external triggering of the fault recorder	42
5.4 Protection parameter "Mains decoupling"	43
5.4.1 Parameter setting of "Over- and under voltage functions"	43
5.4.2 Number of measuring repetitions (T) for frequency functions	43
5.4.3 Threshold values of frequency supervision	44
5.4.4 Tripping delays for the frequency elements	44
5.4.5 Parameter setting for vector surge supervision or frequency gradient speed	44
5.4.6 Voltage threshold value for frequency- and vector surge measuring resp. df/dt - measuring	46
5.5 Protection parameter "Over current"	46

5.5.1	Pickup value for phase over current element	46
5.5.2	Time current characteristics for phase over current element.....	46
5.5.3	Trip delay or time factor for phase over current element	46
5.5.4	Reset mode for all tripping characteristics in the phase current path	47
5.5.5	Pick-up value for high set element	47
5.5.6	Trip delay for high set element	47
5.6	Parameter protection earth fault supervision.....	48
5.6.1	Pick-up value for residual voltage.....	48
5.6.2	Trip delay for residual voltage (only MRG3-IU0 and MRG3-U0)	48
5.6.3	Pick-up value for earth fault element	48
5.6.4	WARN/TRIP changing-over.....	48
5.6.5	Time current characteristics for earth fault element (only MRG3-IE).....	48
5.6.6	Trip delay or time multiplier for earth fault element.....	49
5.6.7	Reset mode for tripping characteristics in earth current path	49
5.6.8	Pick-up value for earth faults resp. earth short circuit fast trips	49
5.6.9	Trip delay for earth fault s resp. earth short circuit fast trips	49
5.6.10	COS/SIN-measurement.....	49
5.7	More Settings	50
5.7.1	Circuit breaker failure protection.....	50
5.7.2	Adjustment of the slave address	50
5.7.3	Setting of Baud-rate (applies for Modbus Protocol only)	50
5.7.4	Setting of parity (applies for Modbus Protocol only)	50
5.8	Fault recorder.....	51
5.8.1	Adjustment of the fault recorder	51
5.8.2	Number of the fault recordings	51
5.8.3	Adjustment of trigger occurrences	51
5.8.4	Pre-trigger time.....	51
5.8.5	Adjustment of the clock	52
5.9	Additional functions	53
5.9.1	Blocking of protection functions and assignment of the output relays	53
5.10	Indication of measuring values	55
5.10.1	Measuring indication for mains decoupling.....	55
5.10.2	Storage of min./max. values	55
5.10.3	Unit of the measuring values displayed	56
5.10.4	Indication of values measured for over current - and earth fault protection.....	56
5.10.5	Units of the measuring values	57
5.10.6	Indication of fault data	58
5.10.7	Fault recorder	58
5.10.8	Erasure of fault storage	59
5.10.9	Reset	60
5.10.10	Delete of disturbance records.....	60
6.	Maintenance and Commissioning	61
6.1	Connection of aux. voltage.....	61
6.2	Testing of the output relays and LEDs	61
6.3	Checking the set values	62
6.4	Test with transformer secondary current (Secondary injection test).....	62
6.4.1	Equipment required to test voltage functions.....	62
6.4.2	Test circuit	63
6.4.3	Checking of the input circuits and measuring functions.....	64
6.4.4	Checking the pick-up and release values for over/under voltage	64
6.4.5	Checking of the tripping delay time for over/under voltage.....	64
6.4.6	Checking of the pick-up and release values for over/under frequency	65
6.4.7	Checking of the tripping delay time for over/under frequency s.....	65
6.4.8	Checking of the vector surge function	65
6.5	Test with transformer secondary current (Secondary injection test).....	66
6.5.1	Equipment required to test voltage functions.....	66
6.5.2	Test circuit for the current function	67
6.5.3	Checking the input circuits and measured values	67
6.5.4	Checking the operating and resetting values of the relay	68
6.5.5	Checking of the tripping delay	68
6.5.6	Checking the high set element of the relay.....	68

6.6	Example of a test circuit for MRG3-IER-relay with earth current directional feature	69
6.7	Checking the external blocking and reset inputs	70
6.7.1	Test of the CB failure protection	70
6.8	Primary injection test	70
6.9	Maintenance	70
7.	Technical data	71
7.1	Measuring input voltage	71
7.1.1	Influences on the voltage measurement	71
7.2	Frequency measurement	71
7.2.1	Influences on the frequency measurement	71
7.3	Measuring input: phase current	72
7.3.1	Influences on the current measurement	72
7.4	Measuring input: Residual voltage	72
7.4.1	Influences on the residual voltage measuring	72
7.5	Measuring input: Earth current	73
7.5.1	Influences on the earth current measuring	73
7.6	Common data	74
7.7	Output relays	74
7.8	Setting ranges and steps	75
7.8.1	System parameter	75
7.8.2	Parameter protection: Voltage protection, Frequency protection, Frequency gradient 77	
7.8.3	Time over current protection	78
7.8.4	Earth fault supervision	79
7.8.5	Earth fault supervision with directional feature	80
7.8.6	Determination of the earth fault direction (MRG3-IER)	80
7.8.7	Residual voltage protection	81
7.8.8	CB failure protection	81
7.8.9	Interface parameter	81
7.8.10	Parameter for the fault recorder	82
7.8.11	Output relay	82
7.8.12	Inverse time over current protection relay	83
7.9	Inverse time characteristics	84
8.	Order form	87

Important Note!

The description "digital Multi-Function Relay MR" is part of the present description including those chapters that are valid for all devices of this High Tech Line such as:

- Characteristics and features
- Technique of MR – Relays
- Operation and settings
- Housing
- Maintenance
- General technical data

Technical data subject to change without notice!

1. Overview and Application

The MRG3 is a universal mains decoupling device that covers all the protection functions which are required by VDEW and by most other utilities for the mains parallel operation of power stations such as:

- over/and under voltage protection,
- over/and under frequency protection,
- extremely fast generator mains decoupling in case of vector surges or rate of change of frequency df/dt

The MRG3 can furthermore be equipped with a multi-purpose over current time and earth fault protection re-lay and it has been designed as to be also used for grids with isolated and compensated star points respectively. It is applicable for the mains parallel operation of power generating gen.-sets and includes the following protection functions.

- Independent (Definite) time over current relay,
- dependent time over current relay with selectable characteristics, independent short circuit protection
- two-element (low and high set) earth fault protection with definite or inverse time characteristics,
- integrated determination of earth fault direction for application to power system networks with isolated star point or earth fault compensation (ER/XR-relay type),
- two-step protection for the residual voltage

For applications where only individual protection functions are required SEG can, of course, also offer the following MR-relays as individual devices:

- MRU3-1 four step independent over-/ and under-voltage protection (also used for generator earth fault protection).
- MRU3-2 two step independent over-/ and under-voltage protection with evaluation of the symmetrical voltage components.
- MRF3 four step independent over/ and under- frequency protection and two step frequency gradient supervision df/dt .
- MRI3-I Independent (Definite) time over current relay, inverse time over current relay with selectable tripping characteristics, independent short circuit protection
- MRI3-E two-element (low and high set) earth fault protection with definite or inverse time characteristics,

General Note

The description of the digital multifunction relay MR is a part of the present description and it includes technical data and details valid for most of the MR devices.

2. Features and Characteristics

- Microprocessor technology with watchdog function.
 - Effective analog low pass filter for suppressing harmonics when measuring frequency, df/dt and vector surge.
 - Digital filtering of the measured values by using discrete Fourier analysis to suppress higher harmonics and d.c. components induced by faults or system operations.
 - Integrated functions for voltage, frequency, df/dt and vector surge in one device.
 - Voltage supervision each with two step under-/and overvoltage detection.
 - Frequency supervision with three step under-/or over frequency (user setting).
 - Completely independent time settings for voltage and frequency supervision.
 - User configurable vector surge measurement 1-of-3 or 3-of-3.
 - Adjustable voltage threshold value for the blocking of frequency-, df/dt or vector surge measuring.
 - Independent time over current protection.
 - Selectable protective functions between:
 - definite time over current relay and
 - inverse time over current relay,
 - Selectable inverse time characteristics according to IEC 255-4:
 - Normal Inverse (type A)
 - Very Inverse (type B)
 - Extremely Inverse (type C)
- Further characteristics:
- Long Time Inverse,
 - RI-Inverse
 - RXIDG characteristic
- Reset mode selectable for inverse time characteristics.
 - Definite time element for short circuit fast trip.
 - Two-step earth fault supervision.
 - Optionally: sensitive, watt metric directional earth fault detection with measurement of the residual voltage.
 - Optionally: supervision of the residual voltage in two steps.
 - Two parameter sets.
 - Circuit breaker failure protection with release for subordinate protection.
 - Functions for the backward blocking.
 - Display of all measuring values and setting parameters for normal operation as well as tripping via alphanumeric display and LEDs.
 - Display of measuring values as primary quantities,
 - Setting of the switching points for current and voltage measured in per cent.
 - Voltage fail-safe storage and indication of tripping values in an error memory, 16 times (voltage fail-safe).
 - Recording of up to four fault events with time stamp in Comtrade format according to IEC60255-25.
 - For the blocking of individual functions via external blocking input, parameters can be set according to requirement.
 - Suppression of indication after completed activation (LED flash).
 - Free assignment of the output relays.
 - Display of date and time.
 - Requirements in compliance with VDE 0435, part 303 and IEC 255.
 - Possibility of serial data exchange via RS485 inter-face possible; alternatively with SEG RS485 Pro-Open Data Protocol or Modbus Protocol.

3. Design

3.1 Connections

3.1.1 Connection Diagrams

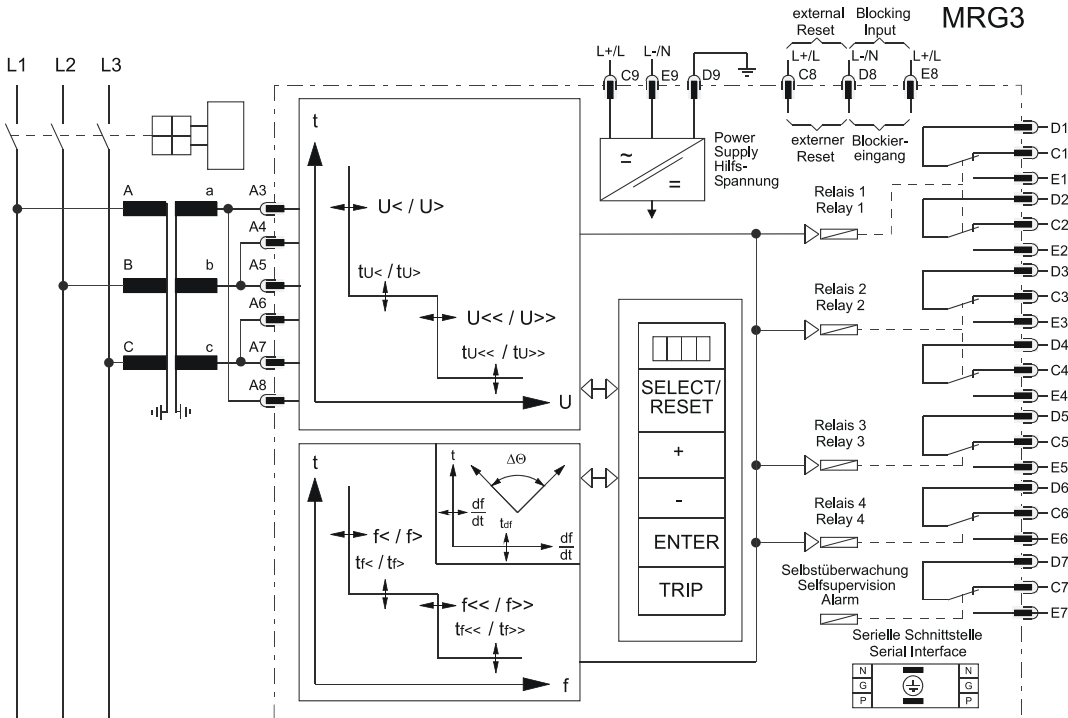


Figure 3.1: Connection diagram "Mains decoupling"

The measuring circuits can optionally be star- or delta connected (see chapter 4.3.1)

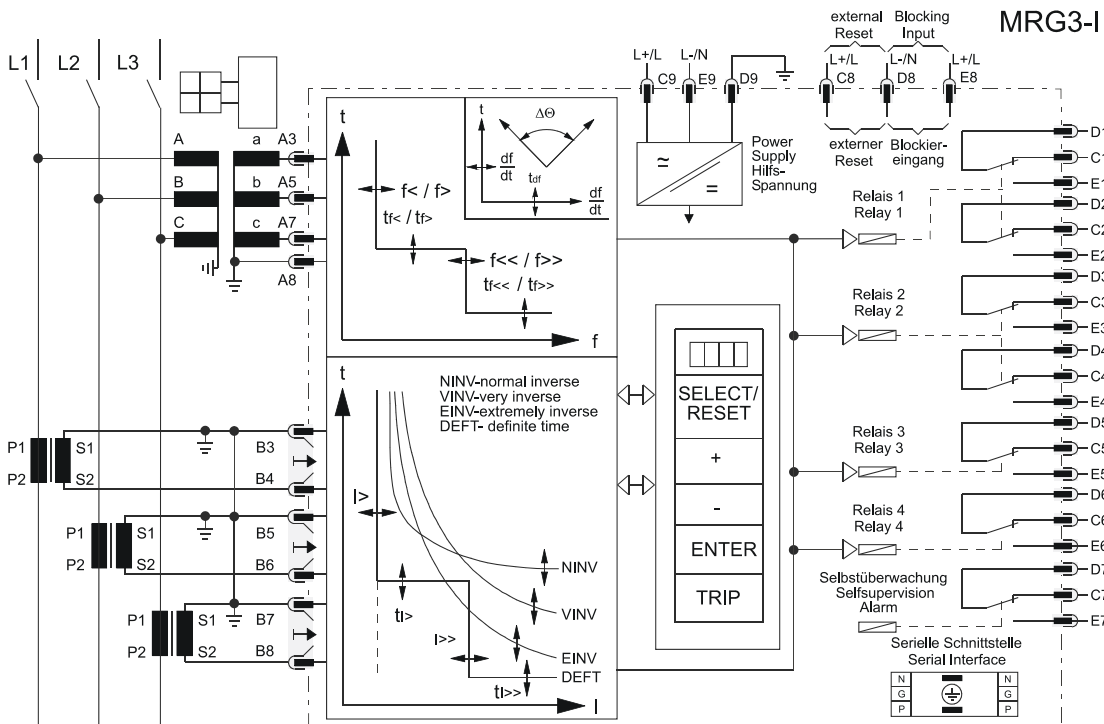


Figure 3.2: MRG3-I Connection diagram "Mains decoupling with time over current protection"

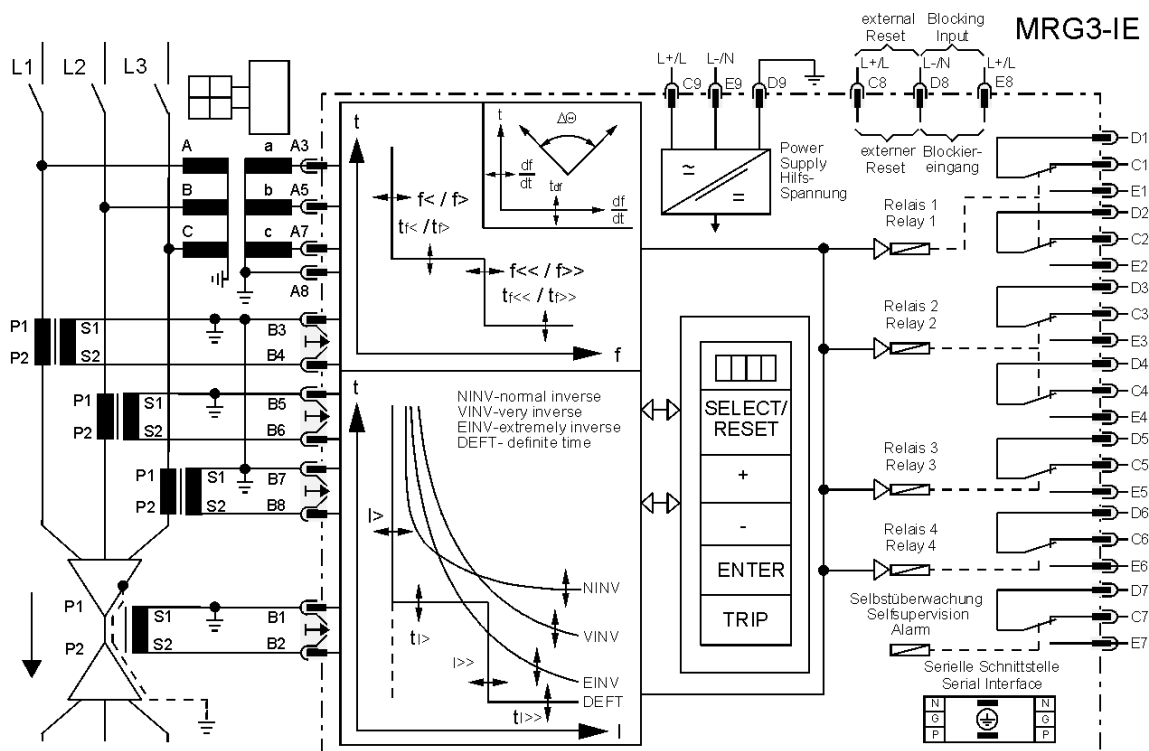


Figure 3.3: MRG3-I Connection diagram "Mains decoupling with time over current protection"

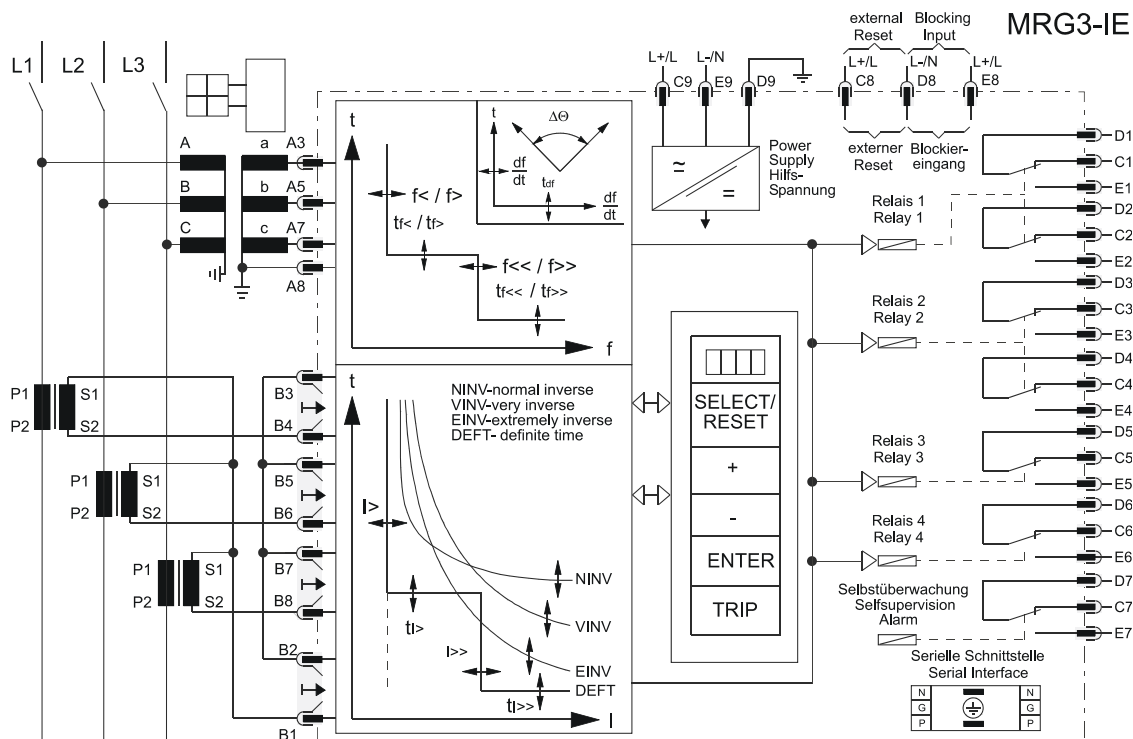


Figure 3.4: Connection diagram with time over current protection and earth fault protection Holmgreen circuit

This connection can be used with three existing phase current transformers when combined phase and earth-current measuring is required. Disadvantage of the Holmgreen-circuit: At saturation of one or more C.Ts the relay seemingly detects an earth current.

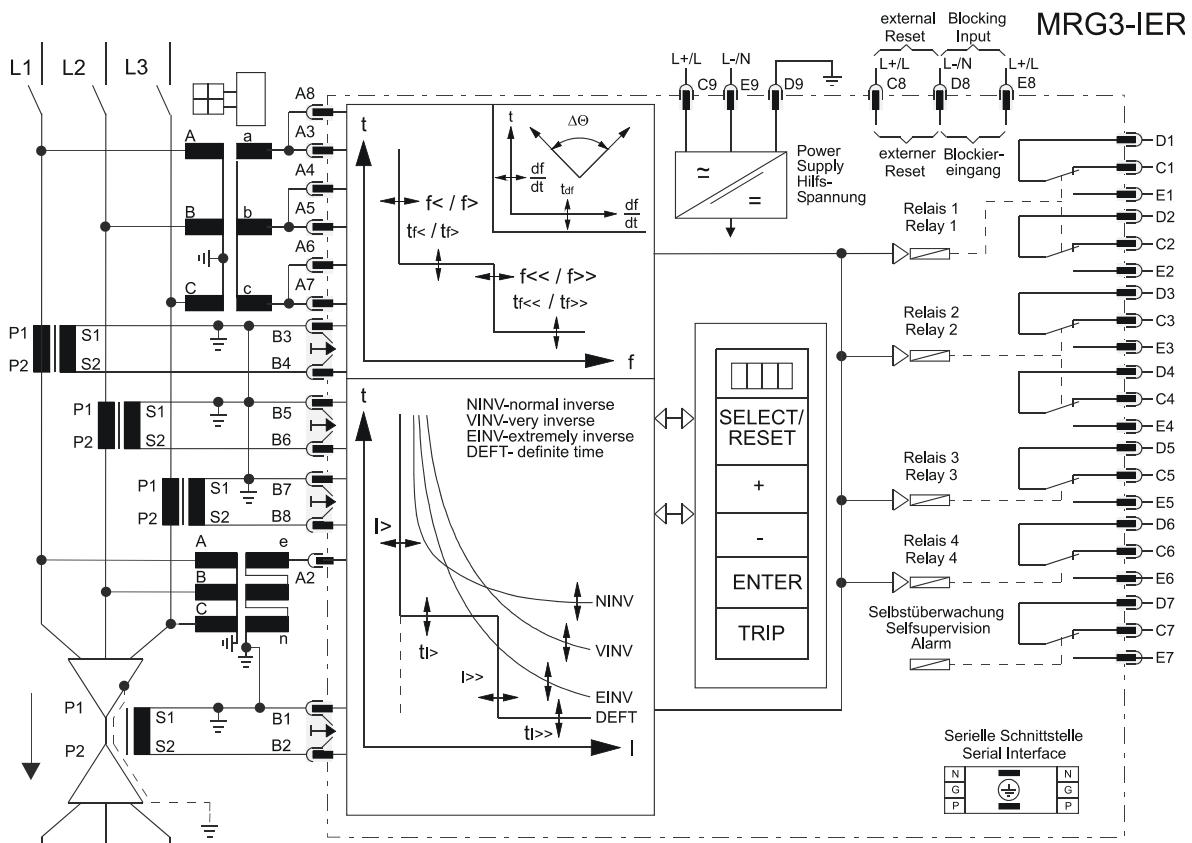


Figure 3.5: Connection diagram with time over current protection and earth fault directional feature

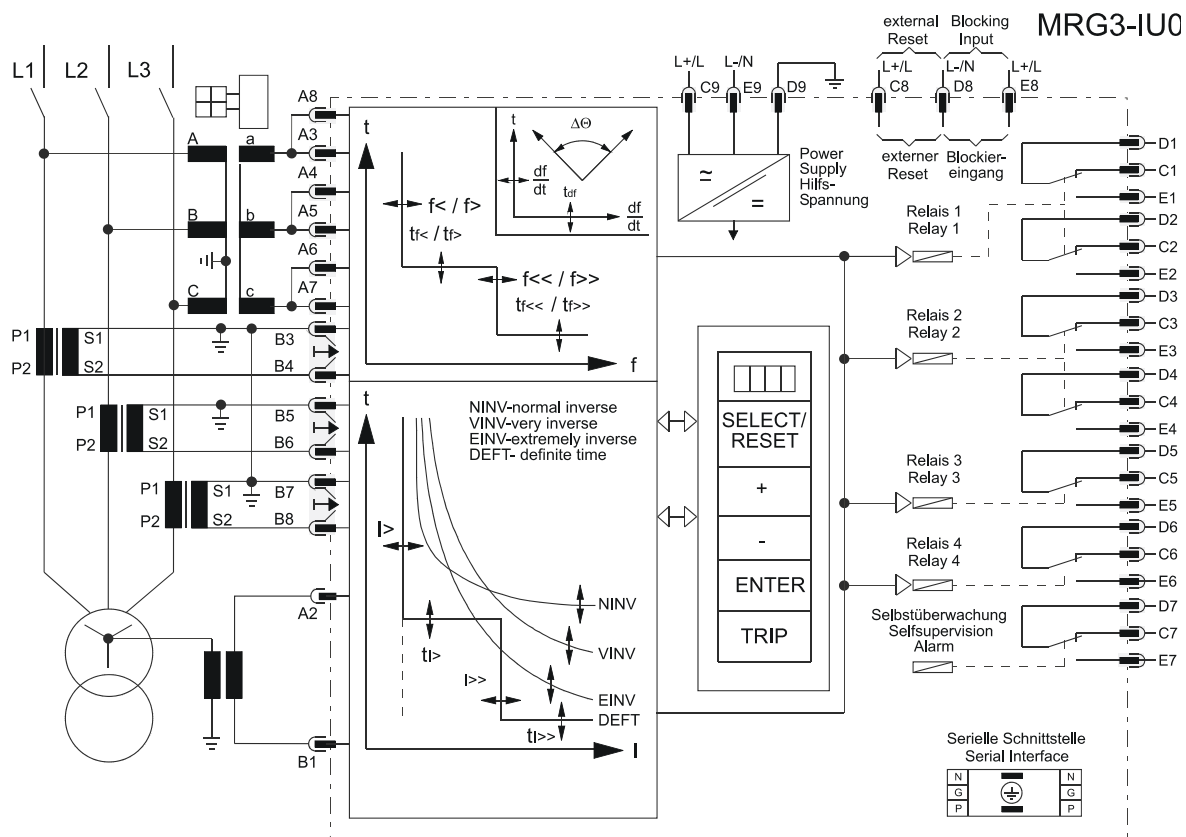


Figure 3.6: Connection diagram with time over current protection and detection of the residual voltage

For the unit version including the earth fault directional feature (ER unit type), the residual voltage U can be generated internally in the secondary measuring circuit. The device shall then be encoded as described in chapter 3.1.8. Thus, star connection of voltage transformers is imperative. For the detection of residual voltage from the open delta winding, it is possible to connect the voltage transformer directly to B1 and A2. Connection of voltage transformers in isolated/compensated grids is explained in chapter 4.7.3

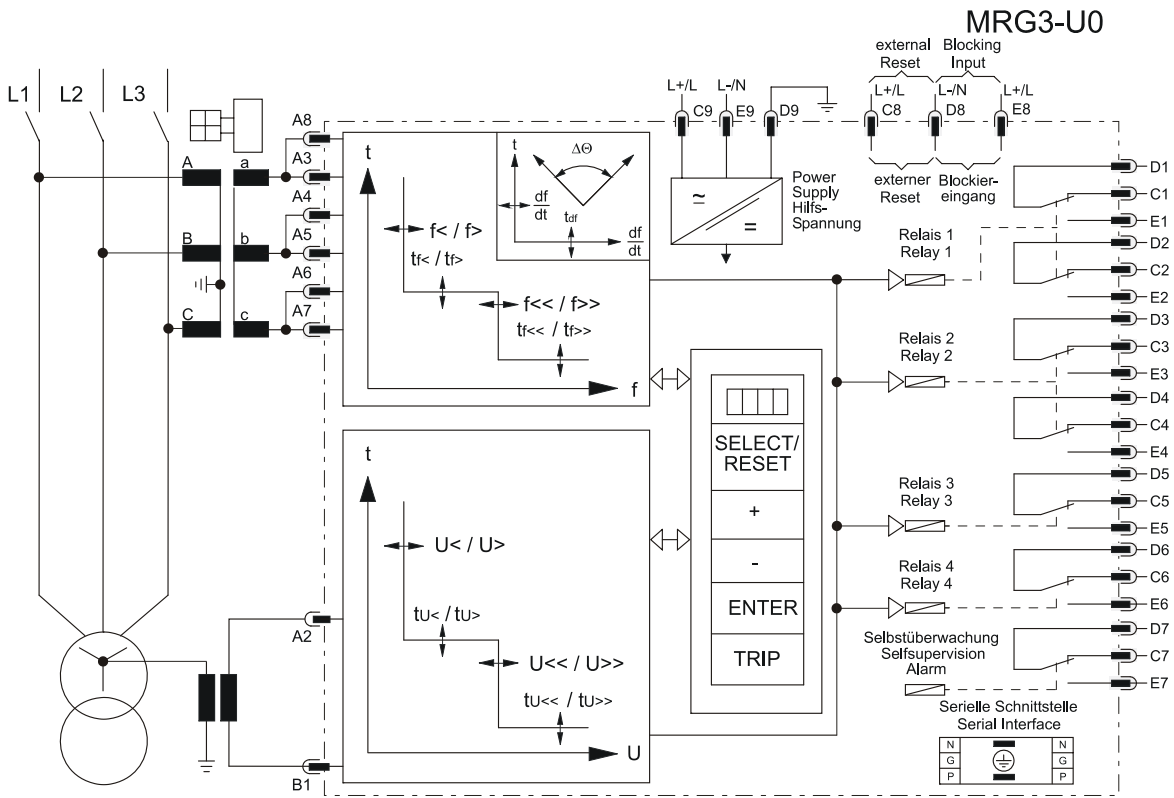


Figure 3.7: Connection diagram with detection of the residual voltage

3.1.2 Analog input circuits

The protection unit receives the analog input signals of the phase currents IL1 (B3-B4), IL2 (B5-B6), IL3 (B7-B8) and the current IE (B1-B2), phase voltages U_{L1} (A3 - A4), U_{L2} (A5 - A6); U_{L3} (A7 - A8) and residual voltage U_0 (A2 - B1), each via separate input transformers.

The constantly detected current measuring values are galvanically decoupled, filtered and finally fed to the analog/digital converter.

The voltage measuring circuits can optionally be star- or delta connected (see chapter 4.3.1)

For the unit type with earth fault directional features (MRG3-IER) the residual voltage U_E in the secondary circuit of the voltage transformers can internally be formed. The device shall then be encoded as described in chapter 3.1.8. Thus, star connection of voltage transformers is imperative.

For the detection of residual voltage from the open delta winding, the voltage transformer can directly be connected to B1 and A2. Connection of voltage transformers in isolated/compensated grids is explained in chapter 4.7.3.

3.1.3 Output relays

The MRG3 is equipped with 5 output relays. Apart from the relay for self-supervision, all protective functions can be optionally assigned:

- Relay 1: C1, D1, E1 and C2, D2, E2
- Relay 2: C3, D3, E3 and C4, D4, E4
- Relay 3: C5, D5, E5
- Relay 4: C6, D6, E6
- Relay 5: Self-supervision C7, D7, E7

All trip and alarm relays are working current relays, the relay for self supervision is an idle current relay.

3.1.4 Blocking input

The blocking function can be set according to requirement. By applying the auxiliary voltage to D8/E8, the previously set relay functions are blocked (see chapter 4.8 and 5.9.1).

3.1.5 External reset input

See chapter 5.10.9.

3.1.6 Serial interface

The serial interface is an RS485 interface that is used for the parameterization of the MRG3 via HTL/PL-Soft4 and for the sorting of recorded sequences of events. The terminal conditions are specified in chapter 5.2 of the description MR – Digital Multifunction Relay.

3.1.7 Auxiliary voltage supply

The MRG3 is supplied with auxiliary voltage by means of the terminals C9 – D9. It has to be made sure that the device is connected to ground by means of terminal D9.

3.1.8 Code plugs

The measuring range of phase and residual voltage can be adjusted via code plugs. For the measuring range from 0 – 150 V, the code plugs have to be adjusted to X-100V; for the measuring range 0 – 600 V, adjust the code plugs to x_400V. the x, in this case, is used as a replacement character for the phases L1, L2, L3 and U_E.

Encoding:

100V L1: Measuring range 0 -150V in phase U_L1
 L2 100V: Measuring range 0 -150V in phase U_L2
 100V L3: Measuring range 0 -150V in phase U_L3
 100V U_E: Measuring range 0 -150V in phase U0
 L1 400V: Measuring range 0 - 60V in phase U_L1
 400V L2: Measuring range 0 - 600V in phase U_L2
 L3 400V: Measuring range 0 . 600V in phase U_L3
 U_E 400V: Measuring range 0 - 600V in phase U0

Based on the set value of the secondary transformers' rated voltage, a change-over to the measuring range is automatically detected by the MRG3 (refer to chapter 5.3.3). This set value determines the secondary rated voltage of the device. If the adjusted value is lower than 138V, the MRG3 relay recognizes the measuring range 0 – 150V; at a value of 138V and up, measuring range 0 – 600V will be detected.

Attention:

Factory setting of the coding plugs is 400V. To avoid damage of the relay, the proper measuring range must always be observed. The measuring range is to be set for each phase separately.

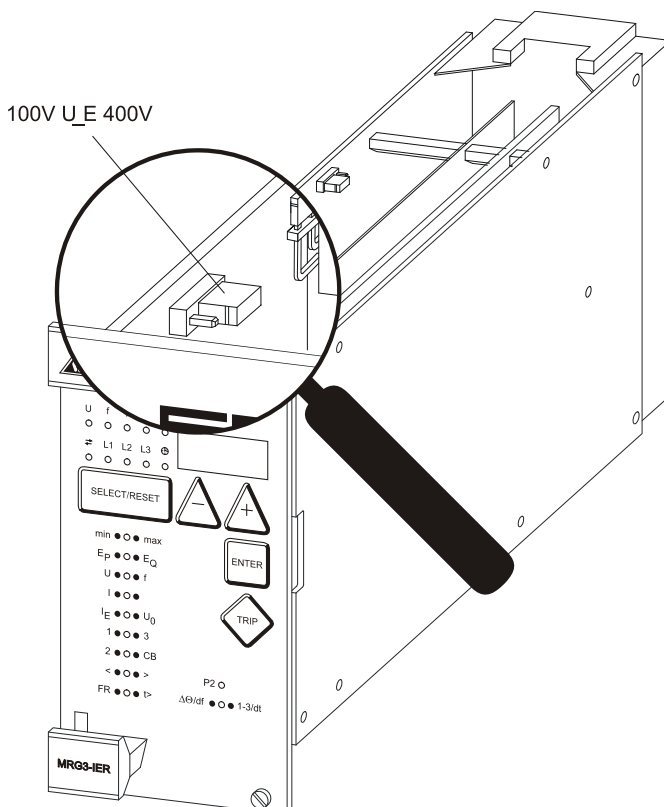


Figure 3.8: Change-over to/of measuring range for residual voltage U0

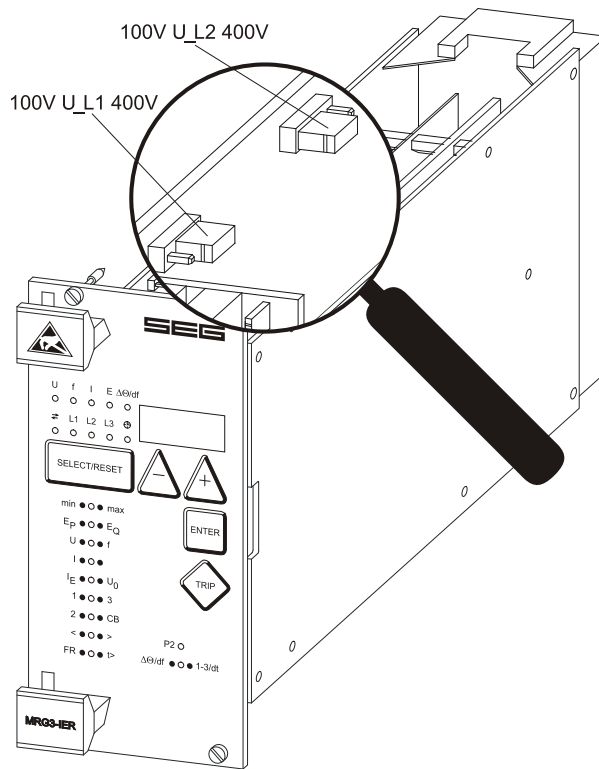


Figure 3.9: Change over to/of measuring range for phase voltages phase I1 and L2

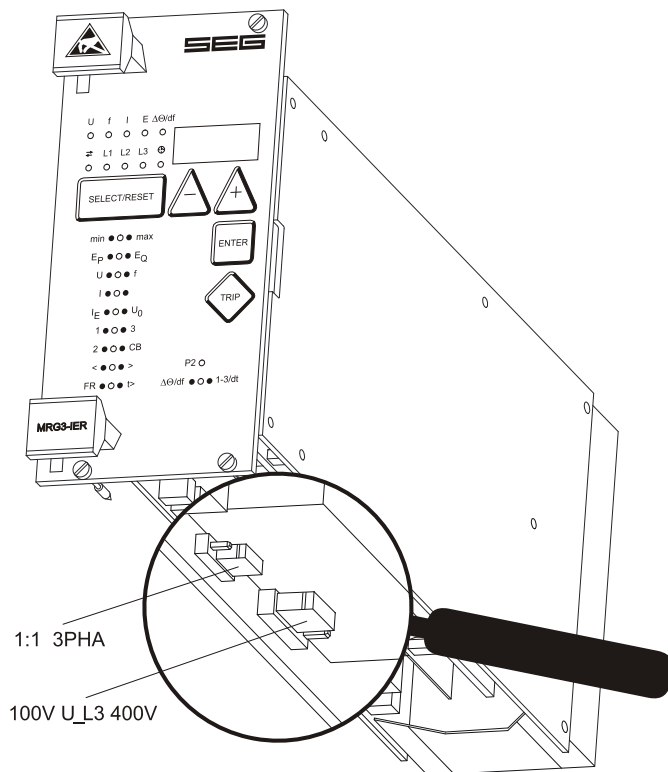


Figure 3.10: Change-over to/of measuring range for phase voltage Phase L3. Selection of the measuring method to be used for residual voltage.

There are three possibilities to measure the residual voltage:

- directly in the star point
- based on the open delta winding
- based on star-connected phase voltages

For detailed description of this function, refer to chapter 4.7.3.

For direct star point measurement as well as for the measurement out of the open delta winding, the MRG3 is equipped with a proper measuring input. For this purpose, the code plug is set to position "1:1". For detection of the residual voltage based on the three star-connected phase voltages, adjust the code plug to "3PHA". The code plug's default position is "1:1".

3.1.9 Low/high range of the digital inputs

The MRG3 is equipped with a power supply unit so that the supply voltage can be freely selected. This means, that the switching threshold of the digital inputs has to be defined dependent on the supply voltage. It is possible to adjust two switching threshold ranges:

- a low range with a switching threshold of
 $U_{AN} \geq 10 \text{ V}$;
 $U_{AB} \leq 8 \text{ V}$ = connector plugged; or
- a high range with a switching threshold of
 $U_{AN} \geq 80 \text{ V}$;
 $U_{AB} \leq 60 \text{ V}$ = connector unplugged.

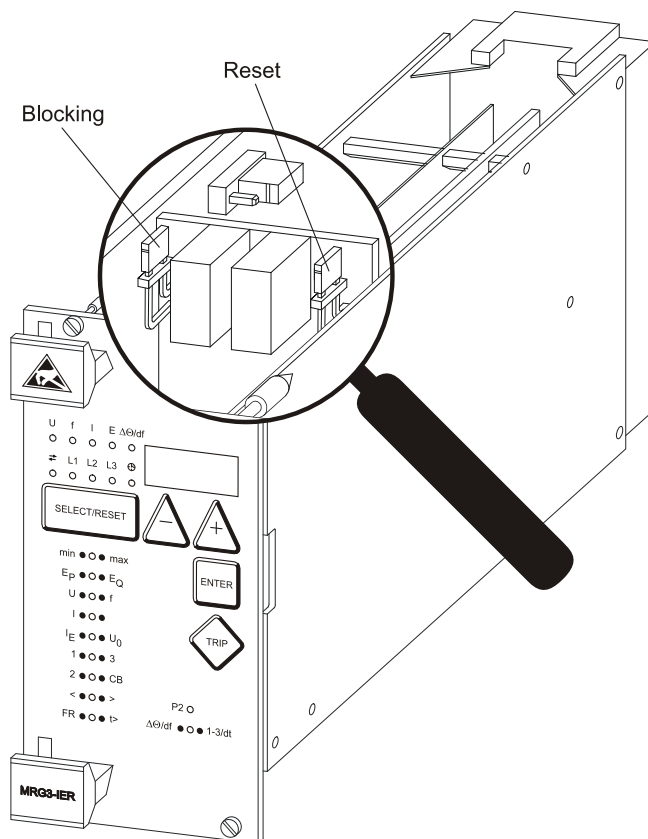


Figure 3.11: Selection of low/high range of the digital inputs

3.2 Front plates

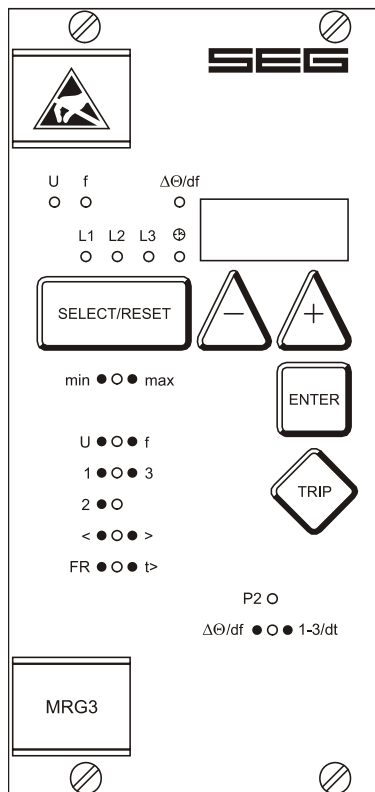


Figure 3.12: Front plate MRG3

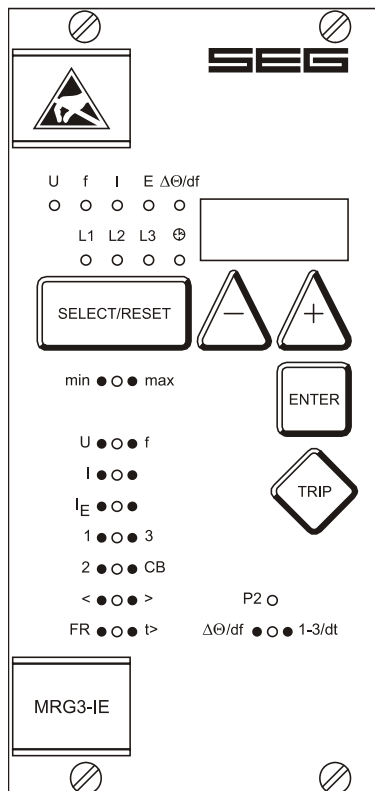


Figure 3.13: Front plate MRG3-IE

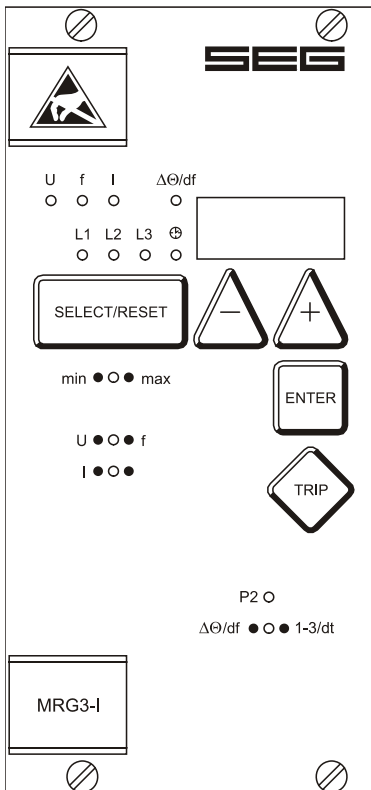


Figure 3.14: Front plate MRG3-IU0

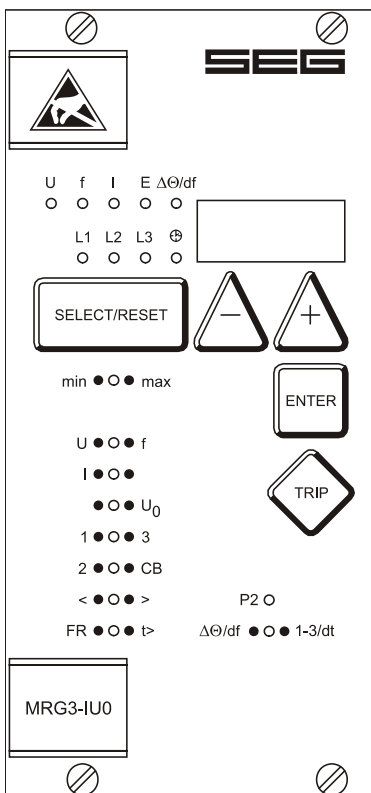


Figure 3.15: Front plate MRG3-I

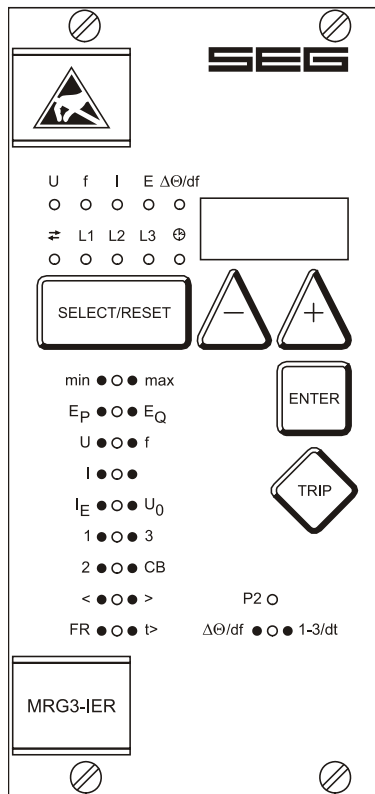


Figure 3.16: Front plate MRG3-IER

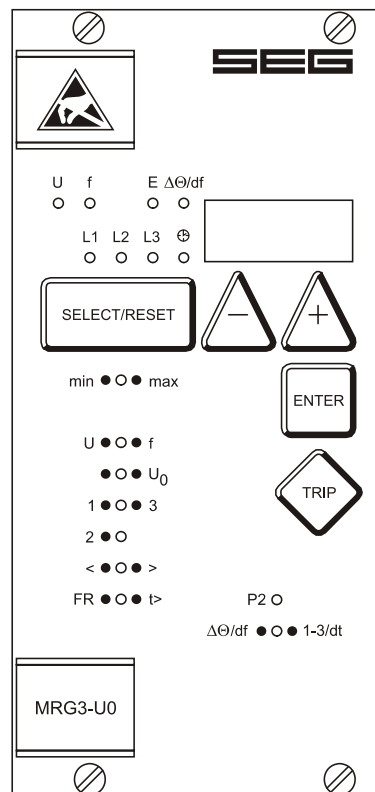


Figure 3.17: Front plate MRG3-U0

3.3 LEDs

All LEDs (except L1, L2, L3 and the clock symbol) are two colored. The LEDs on the left side, next to the alphanumeric display light up green during measuring and red after fault messages.

The LEDs below the push button <SELECT/RESET> are lit green during setting and inquiry procedure of the setting values which are printed on the left side next to the LEDs. The LEDs will light up red during parameterizing of the setting values next to their right side.

Remarks:

Due to the fact that there are a variety of protection functions, it is not possible to assign each individual function to one separate LED. For this reason, some of the measured values or parameters are indicated by simultaneous flashing of several LEDs.

Example: To indicate the function of parameter U<, the LEDs next to U and 1 and < are lit up.

You can find an overall list showing the assignment of functions and LEDs in Chapter 5.1 and at the end of this description.

4. Working Principle

4.1 Analog circuits

The input voltages are galvanically insulated by the input transformers. Thereafter, the influence of noise signals caused by inductive and capacitive coupling is suppressed by an analog R-C filter circuit.

The analog measured voltage signals are fed to the A/D-converter of the microprocessor and then transformed to digital signals through Sample- and Hold- circuits. Any further processing is then based on these digitalized signals. The analog signals are sampled with a sampling frequency of $16 \times f_N$, namely, a sampling rate of 1.25 ms for every measuring quantity at 50 Hz and every 1.04 ms for every measuring quantity at 60 Hz.

4.2 Digital circuits

The essential part of the MRG3 relay is a powerful microcontroller. All of the operations, from the analog digital conversion to the relay trip decision, are carried out by the microcontroller digitally.

The relay program is located in an EPROM (Electrically-Programmable-Read-Only-Memory). With this program the CPU of the microcontroller calculates the three phase voltage in order to detect a possible fault situation in the protected object.

The calculated actual current values are compared with the relay settings. If a phase current exceeds the pickup value, an alarm is given and after the set trip delay has elapsed, the corresponding trip relay is activated.

The relay setting values for all parameters are stored in a parameter memory (EEPROM - Electrically Erasable Programmable Read-only Memory), so that the actual relay settings cannot be lost, even if the power supply is interrupted.

The microprocessor is supervised by a built-in "watch-dog" timer. In case of a failure the watchdog timer resets the microprocessor and gives an alarm signal, via the output relay "self supervision".

4.3 Voltage supervision

The voltage supervision element of the MRG3 is to generally protect generators, consumers and other electrical equipment against over-/and under voltage.

The relay is equipped with a two step independent three-phase overvoltage ($U>$, $U>>$) and Under voltage ($U<$, $U<<$) function with separately adjustable pick-up values and delay times. In delta connection the phase-to-phase voltages and in star connection the phase-to-neutral voltages are continuously compared with the preset thresholds.

For the overvoltage supervision the highest, for the under voltage supervision of the lowest voltage of the three phases are decisive for energizing.

4.3.1 Selection of star or delta connection

All connections of the input voltage transformers are led to screw terminals. The nominal voltage of the device is related to the nominal voltage of the input transformers. Depending on the application the input transformers can be connected in either delta or star. The connection for the phase-to-phase voltage is the delta connection. In star connection the measuring voltage is reduced by $1/\sqrt{3}$. During parameter setting the connection configuration either Y or Δ has to be adjusted.

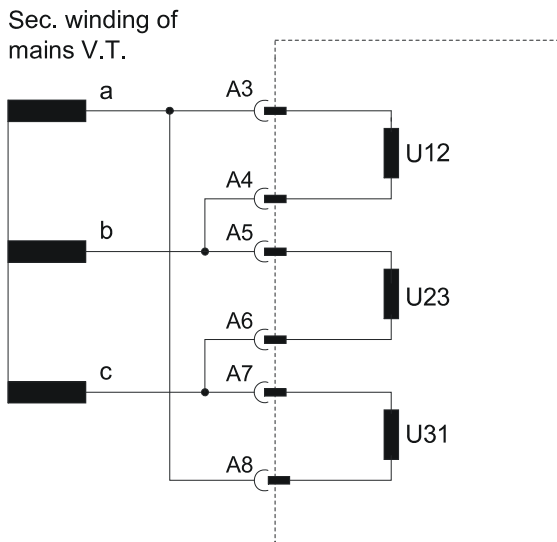


Figure 4.1: Input v.t.s in delta connection (Δ)

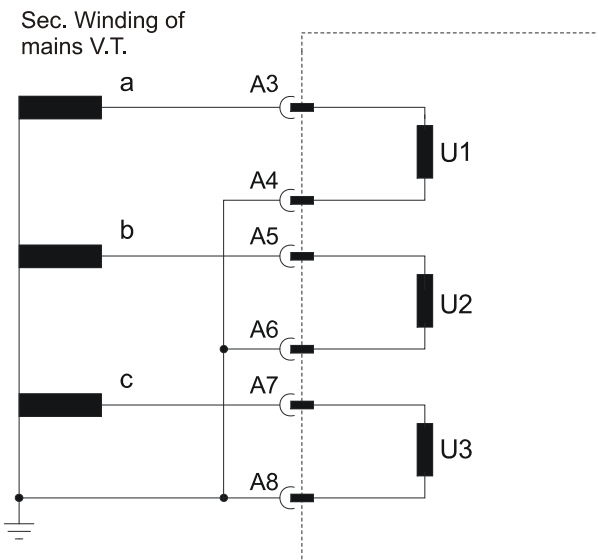


Figure 4.2: Input v.t.s in star connection (Y)

4.4 Principle of frequency supervision

The MRG3 is used to generally protect electrical generators, consumers or electrical operating equipment in general against over- or under frequency. For this purpose, the relay provides three frequency elements $f_1 - f_3$ with a free choice of parameters, with pickup values and delay times that can be independently adjusted.

The measuring principle of the frequency supervision is based in general on the time measurement of complete cycles, whereby a new measurement is started at each voltage zero passage. The influence of harmonics on the measuring result is thus minimized.

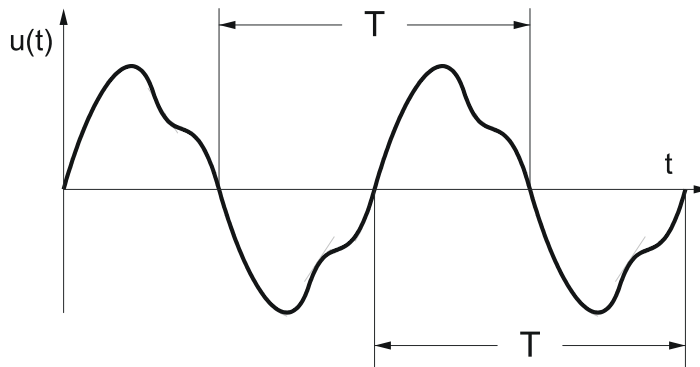


Figure 4.3: Determination of cycle duration by means of zero passages.

In order to avoid false tripping resulting from interference voltages and phase shifts the relay works with an adjustable measuring repetition. (refer to chapter 5.4.2).

At low voltages which, for instance, may occur during start-up of the generator, frequency tripping is some-times not desired.

All frequency supervision functions can be blocked with the aid of an adjustable voltage threshold UB in case the measured voltages value is below this value.

4.5 Mains decoupling

The MRG3 provides two different evaluation criteria for the mains decoupling: measurement of the frequency gradient and supervision of vector surge. By means of parameter setting, it is possible to select one of the two measurement methods.

4.5.1 Measuring of frequency gradients

Electrical generators running in parallel with the mains, e.g. industrial internal power supply plants, should be separated from the mains as soon as possible when a failure in the intrasystem occurs for the following reasons:

- It must be prevented that the electrical generators are damaged due to asynchronous recovery asynchrone, e.g. after a short interruption.
- The industrial internal power supply must be maintained.

A reliable criterion for the detection of a mains failure is the measurement of the rate of change of frequency df/dt . Precondition for this is a load flow via the mains coupling point. At mains failure the load flow changing then spontaneously leads to an increasing or decreasing frequency. At active power deficit of the internal power station a linear drop of the frequency occurs and a linear increase occurs at power excess. Typical frequency gradients during application of "mains decoupling" are in the range of 0.5 Hz/s up to more than 2 Hz/s. The MRG3 detects the instantaneous frequency gradient df/dt of each mains voltage period in an interval of one half period each. Through multiple evaluation of the frequency gradient in sequence the continuity of the directional change (sign of the frequency gradient) is determined. Because of this special measuring procedure a high safety in tripping and thus a high stability against transient processes, e.g. switching procedure are reached. The total switching off time at mains failure is between 60 ms and 80 ms depending on the setting.

4.5.2 Vector surge supervision

The vector surge supervision protects synchronous generators in mains parallel operation due to very fast decoupling in case of mains failure. Very dangerous are mains auto reclosing for synchronous generators. The mains voltage returning after 300 ms can hit the generator in asynchronous position. A very fast de-coupling is also necessary in case of long time mains failures. Generally there are two different applications:

- a) **Only mains parallel operation no single operation:**
In this application the vector surge supervision protects the generator by tripping the generator circuit breaker in case of mains failure.
- b) **Mains parallel operation and single operation:**
For this application the vector surge supervision trips the mains circuit breaker. Here it is ensured that the gen.-set is not blocked when it is required as the emergency set.

A very fast detection of mains failures for synchronous generators running in parallel to the mains is known as very difficult. Voltage supervision units cannot be used because the synchronous alternator as well as the consumer impedance support the decreasing voltage.

For this the mains voltage only drops after some 100 ms below the pickup threshold of voltage supervision relays and therefore a safe detection of mains auto reclosing is not possible with this kind of relay.

To some extent, frequency relays are partial unsuitable because only a highly loaded generator decreases its speed within 100 ms. Current relays detect a fault only when short-circuit type currents exist, but cannot avoid their development. Power relays are able to pick up within 200 ms, but they cannot prevent power to rise to short-circuit values too. Since power changes are also caused by sudden loaded alternators, the use of power relays can be problematic.

Whereas the MRG3 detects mains failures within 60 ms without the restrictions described above because they are specially designed for applications where very fast decoupling from the mains is required.

When adding the operating time of a circuit breaker or the break time of a contractor, the total disconnection time remains below 150 ms. Basic requirement for tripping of the generator/mains monitor is a change in load by at least 15 - 20% of the rated load. Slow changes of the system frequencies, for instance caused by regulating processes (adjustment of speed regulator) do not cause the relay to trip.

Trippings can also be caused by short-circuits within the grid, because a voltage vector surge higher than the preset value can occur. Short-circuits within the grid may also lead to trippings, though here, too the vector surge could be higher than the preset value. The magnitude of the voltage vector surge depends on the distance between the short circuit and the generator. This function is also of advantage to the Power Utility Company because the mains short-circuit capacity and consequently the energy feeding the short circuit is not unnecessarily increased.

To prevent a possible false tripping the vector surge measuring can be blocked at a very low input voltage (refer to 5.9.1). The undervoltage lockout acts faster than the vector surge measurement.

Vector surge tripping is blocked by a phase loss so that a VT fault (e.g. faulty VTs fuse) does not cause false tripping. When switching on the aux. voltage or measuring voltage, the vector surge supervision is blocked for 5 s (refer to chapter 4.8).

4.5.3 Measuring principle of vector surge supervision

When a synchronous generator generates power, the so-called rotor displacement angle is built between the terminal voltage (mains voltage U_1) and the synchronous internal voltage (U_p). This rotor angle produces a voltage difference ΔU is built between U_p and U_1 (Fig. 4.4).

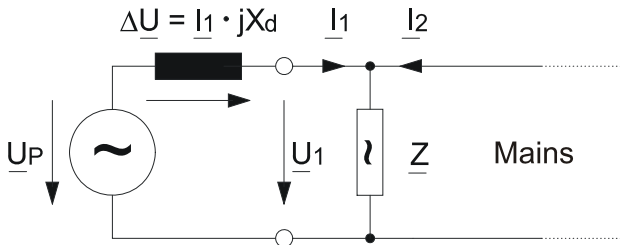


Figure 4.4: Equivalent circuit for synchronous generators running in parallel with the mains

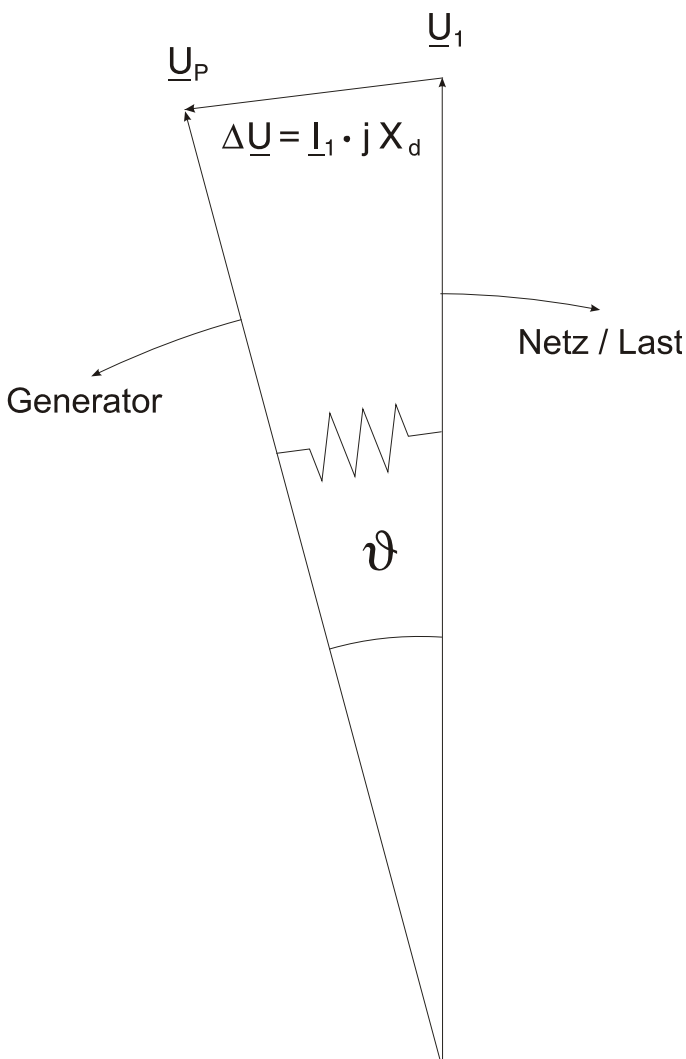


Figure 4.5: Chngement of the rotor displacement angle at sudden load of the generator

The rotor displacement angle between stator and rotor is depending on the mechanical moving torque of the generator shaft. The mechanical shaft power is balanced with the electrical fed mains power, and therefore the synchronous speed keeps is maintained (Fig. 4.5).

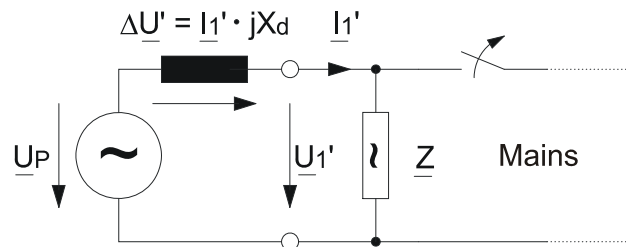


Figure 4.6: Equivalent circuit for mains failure

In case of mains failure or auto reclosing the generator suddenly feeds a very high consumer load. The rotor displacement angle is suddenly increases and the voltage vector U_1 changes its direction (U_1') (Fig. 4.6 and 4.7)

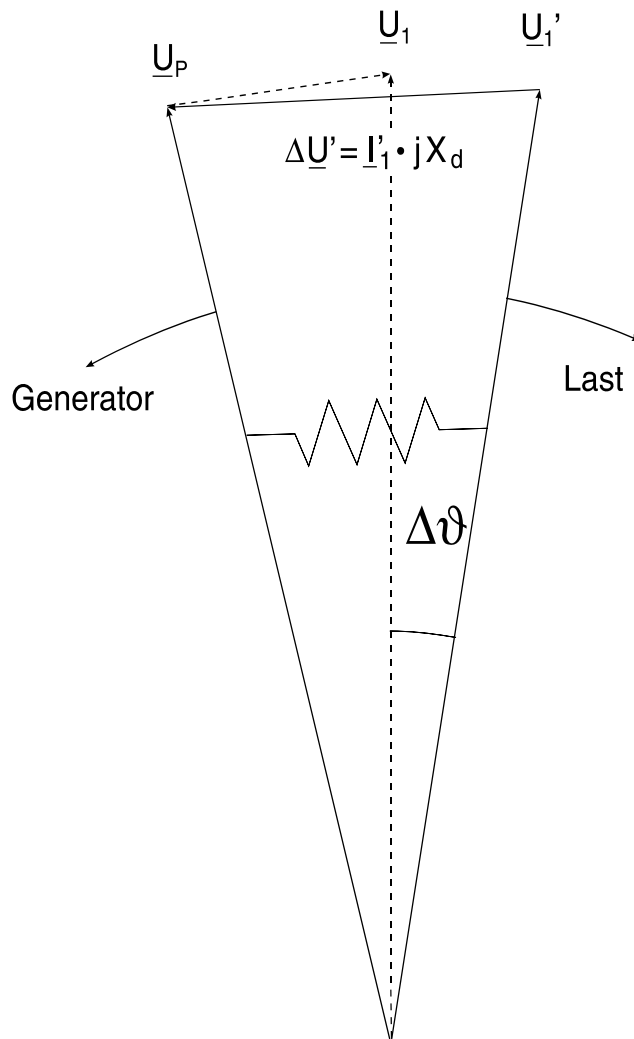


Figure 4.7: Chngement of the rotor displacement angle at sudden load of the generator

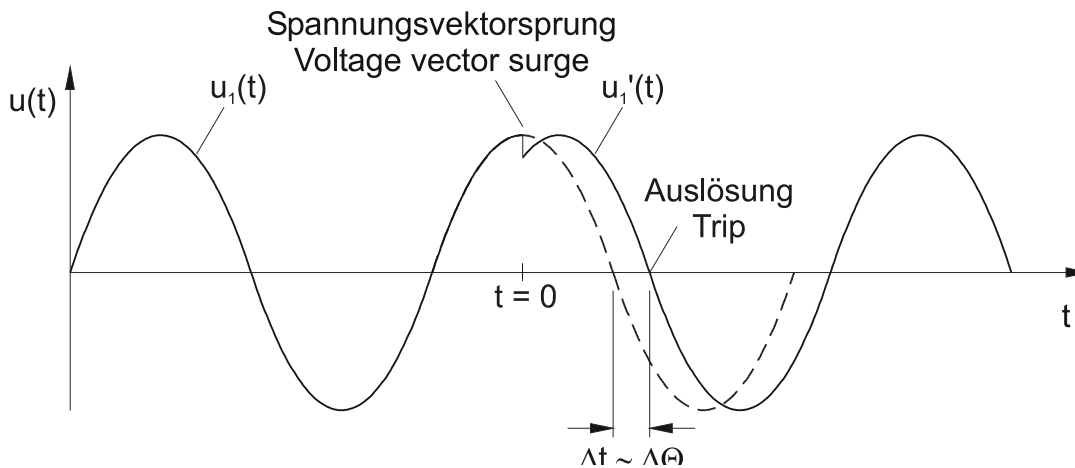


Figure 4.8: Voltage Vector surge

As shown in the voltage/time diagram the instantaneous value of the voltage jumps to another value and the phase position changes. This instance is generally called phase or vector surge.

The MRG3 measures the cycle duration. A new measuring is started at each voltage zero passage. The measured cycle duration is internally compared with a quartz stable reference time and from this the deviation of the cycle duration of the voltage signal is ascertained. In case of a vector surge as shown in fig. 4.8, the zero passage occurs either earlier or later. The established deviation of the cycle duration is in compliance with the vector surge angle.

If the vector surge angle exceeds the set value, the relay trips without delay.

Tripping of the vector surge is blocked in case of loss of one or more phases of the measuring voltage.

Tripping logic for vector surge measurement:

The vector surge function of the MRG3 supervises vector surges in all three phases at the same time. Irrespective of this, tripping of the relay can be adjusted for an one phase vector surge (more sensitive measurement). For this purpose, the parameter 1/3 has to be set to "1Ph". When the parameter 1/3 is set to "3Ph", tripping of the vector surge element occurs only if, in case of a vector surge, the vector surge angle exceeds the set value simultaneously in all three phases at the same time.

Application hint

Although the vector surge relay guarantees very fast and reliable detection of mains failures under nearly all operational conditions of mains parallel running alternators, the following borderline cases, however, have to be considered:

a) During mains failure: none or only insignificant change of power flow at the utility connection point during mains failures.

This can occur in peak lopping operation or in CHP stations (Combined Heat and Power) where the power flow between power station and the public grid may be very low. To allow the detection of a vector surge at parallel running alternators, the load change must be at least 15 - 20% of the rated power. If the active load at the utility connection point is regulated to a minimal value and a high resistance mains failure occurs, then there are no vector surge nor power and frequency changes and the mains failure is consequently not detected.

This can only happen if the public grid is disconnected near the power station and so the alternators are not additionally loaded by any consumers. At distant mains failures the synchronous alternators are abruptly loaded by remaining consumers which leads directly to a vector surge and so mains failure detection is guaranteed.

If such a situation occurs the following has to be taken into account:

In case of an undetected mains failure, i.e. with the mains coupling C.B. closed, the vector surge relay re-acts upon the first load change causing a vector surge and disconnects the mains C.B.

Another possibility to detect high resistance mains failures is to apply a zero current relay with an adjustable trip delay can be used. A trip delay is needed to allow regulating actions where the current may reach "zero" at the utility connection point. At high resistance mains failures, the mains coupling C.B. is tripped by the zero current relay after expiry of the time delay.

To prevent asynchronous switching on, an automatic reclosing of the public grid should be blocked for at least this time delay.

A further measure could be that the load regulation at the utility connection point always guarantees a minimum power flow of 15 - 20% of the rated power.

b) Short circuit type loading of the alternators at distant mains failures

At any distant mains failure, the remaining consumers cause sudden short circuit type loading of the power station generators. The vector surge relay detects the mains failure in about 60 ms and switches off the mains coupling C.B. Thus, the total switch off time is about 100 - 150 ms. If the individual generators are provided with an extremely fast short circuit protection with e.g. di/dt detection function, the alternators might be switched off unselectively by the generator C.B. This, however, is not desirable because the power supply for internal requirements is endangered and a subsequent synchronized changeover to the mains can only be done after manual reset of the over current protection.

To avoid such a situation, the alternator C.B.s must have a delayed short circuit protection whose time delay is at least long enough to allow mains decoupling by the vector surge relay.

4.5.4 Voltage threshold value for frequency, df/dt and vector surge measuring

At low measuring voltages, e.g. during generator start-up, frequency and vector surge or df/dt -measuring is perhaps not desired.

By means of the adjustable voltage threshold value $UB<$, functions $f_1 - f_3$, df/dt or $\Delta\Theta$ are blocked if the measured voltage falls below the set value.

4.6 Over current- and short circuit supervision

The phase current supervision element of the MRG3 generally protects generators; consumers or operational supplements from over current and short-circuit. The relay provides a two-step over current and short-circuit supervision function.

The over current function either works with an independent IDMT protection or with a DMT protection, tripping delay. For the IDMT – protection, it is possible to optionally activate a function for the detection of intermittent errors. If the fault detection is interrupted during the excitation phase, the expired excitation time will be retained for a period of 60 seconds. If the fault is newly detected within this period, the excitation time continues running. This is to prevent that faults that always recur within these 60 seconds, but whose lifetime is lower than the adjusted excitation time are switched off safely.

The short-circuit protection is a one-step protection with un-delayed tripping or adjustable delay time.

4.7 Earth fault protection

4.7.1 Generator stator earth fault protection

With the generator neutral point earthed as shown in Figure 4.9, the MRG3 picks up only to phase earth faults between the generator and the location of the current transformers supplying the relay. Earth faults beyond the current transformers, i.e. on the consumer or line side, will not be detected.

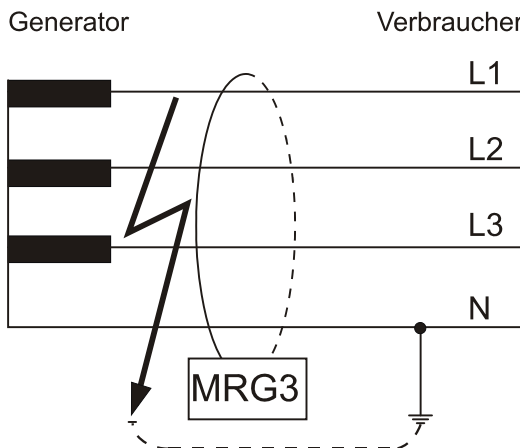


Figure 4.9: Generator stator earth fault protection

4.7.2 System earth fault protection

With the generator neutral point earthed as shown in Figure 4.10, the MRG3 picks up only to earth faults at consumer or line side. It does not pick up to earth faults on the generator terminals or in generator stator.

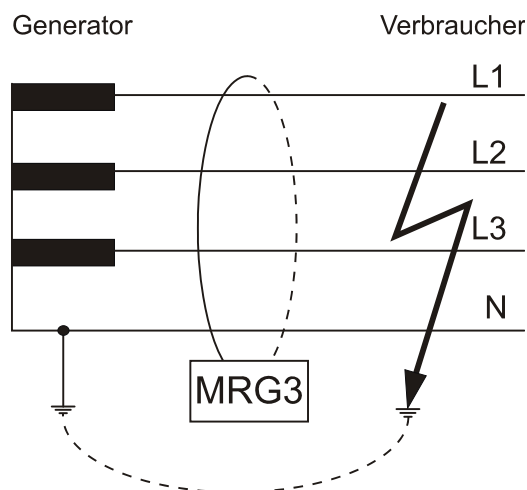


Figure 4.10: System earth fault protection

4.7.3 Earth-fault directional feature

A built-in earth-fault directional element is available for applications to power networks with isolated or with arc suppressing coil compensated neutral point.

For earth-fault direction detection it is mainly the question to evaluate the power flow direction in zero sequence system. Both the residual voltage and neutral (residual) current on the protected line are evaluated to ensure a correct direction decision.

In isolated or compensated systems, measurement of reactive or active power is decisive for earth-fault detection. It is therefore necessary to set the ER/XR-relay type to measure according to $\sin \varphi$ or $\cos \varphi$ methods, depending on the neutral-point connection method.

The residual voltage U_E required for determining earth fault direction can be measured in three different ways, depending on the voltage transformer connections. (see Table 4.1).

Total current can be measured by connecting the unit either to a ring core C.T. or to current transformers in a Holmgreen circuit. However, maximum sensitivity is achieved if the MRG3 protective device is connected to a ring core C. T. (see Figure 3.4).

The pick-up values $I_{E>}$ and $I_{E>>}$ (active or reactive current component for $\cos \varphi$ or $\sin \varphi$ method) for ER-relay types can be adjusted from 0.01 to $0.45 \times I_N$.

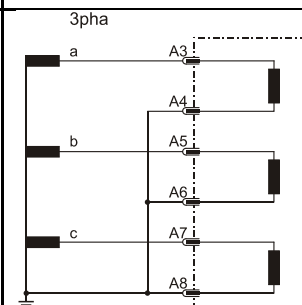
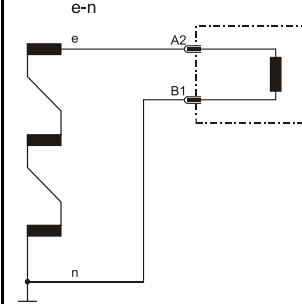
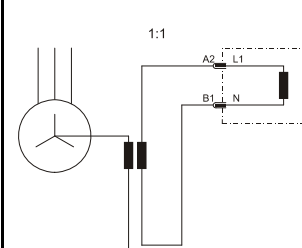
Adjustment possibility	Application see chapter Fehler! Verweisquelle konnte nicht gefunden werden.	Voltage transformer connections	Measured voltage at earth fault	Correction factor for residual voltage
„3pha“	3-phase voltage transformer connected to terminals A3-A4, A5-A6, A7-A8 (MRG3-IER; MRG3-IU0; MRG3-U0) Encoding of the terminal strip X19 to 3PHA		$\sqrt{3} \times U_N = 3 \times U_{1N}$	$K = 1/3$
„e-n“	e-n winding connected to terminals B1, A2 (MRG3-IER; MRG3-IU0; MRG3-U0) Encoding of the terminal strip X19 to 1:1		$U_N = \sqrt{3} \times U_{1N}$	$K = 1/\sqrt{3}$
„1:1“	Neutral-point voltage (= residual voltage) terminals B1, A2 (MRG3-IER; MRG3-IU0; MRG3-U0) Encoding of the terminal strip X19 to 1:1		$U_{1N} = U_{NE}$	$K = 1$

Table 4.1: Connection of the voltage transformers

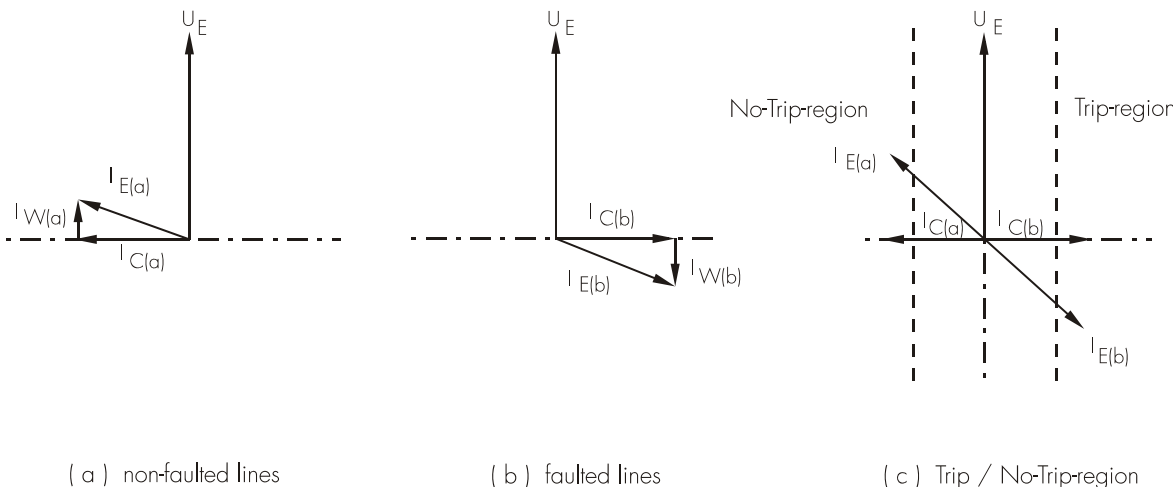


Figure 4.11: Phase position between the residual voltage and zero sequence current for faulted and non-faulted lines in case of isolated systems ($\sin \varphi$)

- U_E -residual voltage
- I_E -zero sequence current
- I_C -capacitive component of zero sequence current
- I_W -resistive component of zero sequence current

By calculating the reactive current component ($\sin \varphi$ adjustment) and then comparing the phase angle in relation to the residual voltage U_E , the ER/XR-relay type determines whether the line to be protected is earth-faulted.

On non-earth-faulted lines, the capacitive component $I_{C(a)}$ of the total current precedes the residual voltage by an angle of 90° . In case of a faulty line the capacity current $I_{C(b)}$ lags behind the residual voltage at 90° .

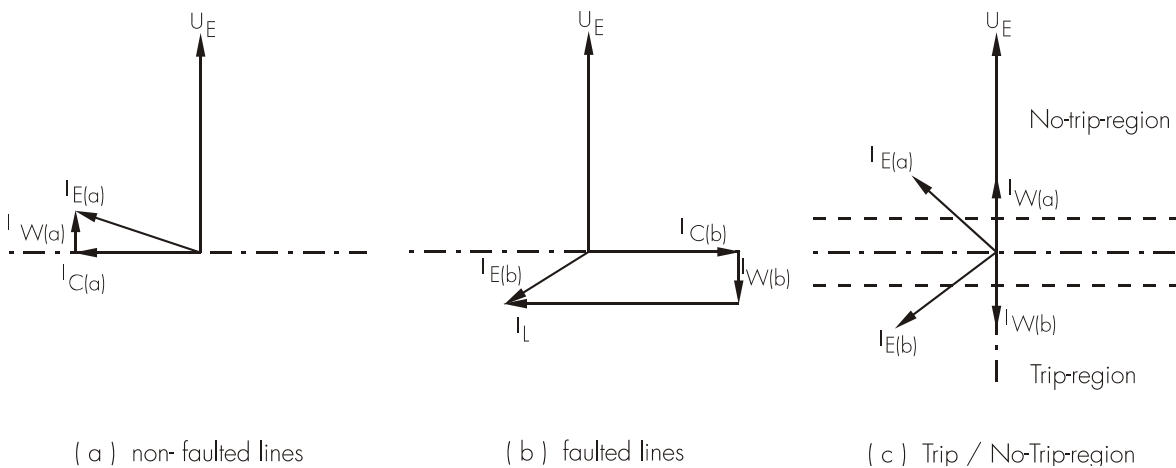


Figure 4.12: Phase position between the residual voltage and zero sequence current for faulted and non-faulted lines in case of compensated systems ($\cos \varphi$)

- U_E residual voltage
- I_E zero sequence current
- I_L inductive component of zero sequence current (caused by Petersen coil)
- I_C capacitive component of zero sequence current
- I_W resistive component of zero sequence current

In compensated mains the earth fault direction cannot be determined from the reactive current components because the reactive part of the earth current depends upon the compensation level of the mains. The ohmic component of the total current (calculated by $\cos \varphi$ adjustment) is used in order to determine the direction.

The resistive component in the non-faulted line is in phase with the residual voltage, while the resistive component in the faulted line is opposite in phase with the residual voltage.

By means of an efficient digital filter harmonics and fault transients in the fault current are suppressed. Thus, the uneven harmonics which, for instance, are caused an electric arc fault, do not impair the protective function.

4.7.4 Residual voltage

In the MRG3-IER – relay, the detection of residual voltage has only a warning function because residual voltage here is used for the directional detection. The MRG3-IUO implies a two-step protection.

4.7.5 Behavior of MRG3 under different operating conditions

Nr.	Dynamic Behaviour	U</<<	U>/>>	f ₁ , f ₂ , f ₃	ΔΘ	df/dt
1	voltage to external blocking input is applied	free programmable	free programmable	free programmable	free programmable	free programmable
2	blocking input is released	released instantaneously	released instantaneously	released after 1 s	released after 5 s	released after 5 s
3	supply voltage is switched on	blocked for 200 ms	blocked for 200 ms	blocked for 1 s	blocked for 1 s	blocked for 1 s
4	3ph measuring volt. is suddenly applied	released	released	blocked for 1 s	blocked for 5 s	blocked for 5 s
5	one or several measuring voltages are switched off suddenly (phase failure)	released	released	blocked	blocked	blocked
6	measuring voltage smaller U _B < (adjustable voltage threshold value)	released	released	blocked	blocked	blocked

Table 4.2: Dynamic behaviour of functions for the mains decoupling in the MRG3

Nr.	Dynamic Behaviour	I>	I>>	IE>	ER>	UO>*
1	voltage to external blocking input is applied	free programmable	free programmable	free programmable	free programmable	free programmable
2	blocking input is released	released instantaneously	released instantaneously	released instantaneously	released instantaneously	released instantaneously

*not MRG3-IER

Table 4.3: Dynamic behavior of functions for the current protection in the MRG3

4.7.6 Blocking function set in compliance with requirements

The MRG3 has an external blocking input. By applying the auxiliary voltage to input D8/E8, the requested protection functions of the relay are blocked (refer to 5.9.1).

4.8 Fault recorder

The MRG3 has a fault value recorder which records the measured analog values as instantaneous values.

The instantaneous values

or $U_{L1}; U_{L2}; U_{L3}$ U_O for star connection
 $U_{12}; U_{23}; U_{21}$ for delta connection
 and
 $i_{L1}, i_{L2}, i_{L3}, i_E,$

are scanned at a raster of 1.25 ms (at 50 Hz) and 1.041 ms (at 60 Hz) and saved in a cyclic buffer. The max. total recording times are 20 s (at 50 Hz) and 16.66s (at 60 Hz).

This only applies to unit versions MRG3 and MRG3-U0. The recording time of all other unit types is 10 s at 50 Hz and 8.33 s at 60 Hz.

Storage division

Independent of the recording time, the entire storage capacity can be divided into several cases of disturbance with a shorter recording time each. In addition, the deletion behavior of the fault recorder can be influenced.

No writing over

If 2, 4 or 8 recordings are chosen, the complete memory is divided into the relevant number of partial segments. If this max. number of fault event has been exceeded, the fault recorder blocks any further recordings in order to prevent that the stored data are written over. After the data have been read and deleted, the recorder to ready again for further action.

Writing over

If 1, 3 or 7 recordings are chosen, the relevant number of partial segments is reserved in the complete memory. If the memory is full, a new recording will always write over the oldest one.

When there is no more storage capacity left, the LED FR starts flashing.

The memory part of the fault recorder is designed as circulating storage. In this example 7 fault records can be stored (written over).

Memory spaces 6 – 4 are occupied
 Memory space 5 is just being written over

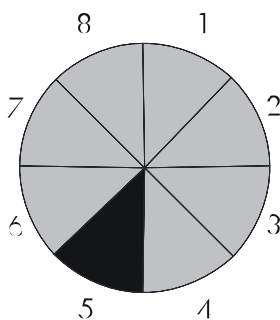


Figure 4.13: Division of the memory into 8 segments, for example

Since memory spaces 6, 7 and 8 are occupied, this example shows that the memory has been assigned more than eight recordings. This means that No. 6 is the oldest fault recording and No. 4 the most recent one.

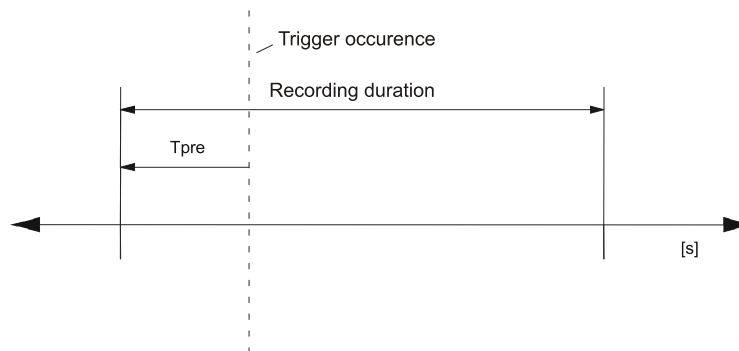


Figure 4.14: Basic set-up of the fault recorder

Each memory segment has a specified storage time which permits setting of a time prior to the trigger event.

Via the interface RS485 the data can be read and processed by means of a PC (HTL/PL-Soft4). The data is graphically edited and displayed. Binary tracks are re-corded as well, e.g. activation and trip.

5. Operation and Settings

5.1 Display

The table below shows the different special symbols used. Detailed information on the functions can be taken from the appropriate chapters, not all the functions, however, are described in all devices. From the setting list, at the end of this description you can see which functions can be found in the different relays.

Function	Display shows	Pressed pushbuttons required	Corresponding LED	Chapter
Normal operation	SEG	<SELECT/RESET> 3s		
Measured operating values	Voltage in L1 Voltage in L2 Voltage in L3 Alternatively: Voltage in L1/L2 Voltage in L2/L3 Voltage in L3/L1 Frequency measuring value: Min. value Max. value Vector surge in L1 Vector surge in L2 Vector surge in L3 Alternatively: Vector surge in L1/L2 Vector surge in L2/L3 Vector surge in L3/L1 Min. value Max. value Alternatively: Frequency gradient df Min. value Max. value Apparent current in L1 Apparent current in L2 Apparent current in L3 Residual voltage U_0 Earth current Active component E_P Reactive component E_Q Angle I_E and U_0	<SELECT/RESET> one time for each value	U+L1 U+L2 U+L3 U+L1+L2 U+L2+L3 U+L3+L1 f f+min f+max $\Delta\Theta/df+L1$ $\Delta\Theta/df+L2$ $\Delta\Theta/df+L3$ $\Delta\Theta/df+L1+L2$ $\Delta\Theta/df+L2+L3$ $\Delta\Theta/df+L3+L1$ $\Delta\Theta/df+min$ $\Delta\Theta/df+max$ $\Delta\Theta/df$ $\Delta\Theta/df+min$ $\Delta\Theta/df+max$ I+L1 I+L2 I+L3 U+E I+E I+E+ E_P I+E+ E_Q U+I+E	5.10
Display of date and time	Year: Y = 06 Month: M = 01 Day: D = 04 Hour: h = 12 Minute: m = 2 Second: s = 12	<SELECT/RESET> <+><->	⊕	5.8.5
Setting values: star/delta connection	Y/DELT	<SELECT/RESET> <+><->	U	4.3.1 5.3.1
Primary rated transformer voltage	SEK.. setting value in kV	<SELECT/RESET><+><->	U+L1+L2+L3+1	5.3.2
Setting value in V		one time for each value	U+L1+L2+L3+2	5.3.3
Sec. rated transformer voltage	SEK.. setting value in kV		U+L1+L2+L3+3	5.3.4
Primary rated generator voltage				5.10.3
Primary rated transformer current	SEK.. setting value in kA	<SELECT/RESET><+><->	I+L1+L2+L3+1	5.3.2
Primary rated generator current	SEK.. setting value in kA	one time for each value	I+L1+L2+L3+2	5.3.4
				5.10.4
Primary rated residual voltage	SEK.. setting value in kV	<SELECT/RESET><+><->	U+E+1	5.3.2
Setting value in V		one time for each value	U+E+2	5.3.3
Sec. rated transformer				5.3.4

Function	Display shows	Pressed pushbuttons required	Corresponding LED	Chapter
voltage for residual voltage Primary rated generator residual voltage	SEK.. setting value in kV		U+E+3	5.10.4
Method used to measure residual voltage	3PHA, E:N, 1:1	<SELECT/RESET><+><-> one time for each value	U+E	4.7.3 5.3.5
Primary rated transformer current for earth fault Primary rated generator current for earth fault	SEK.. setting value in kA SEK.. setting value in kA	<SELECT/RESET><+><-> one time for each value	I+E+1 I+E+2	5.3.2 5.3.4 5.10.4
Rated frequency	F=50, f=60	<SELECT/RESET><+><-> one time for each value	f	0
Selection of vector surge or df/dt	dPhi/dfdt	<SELECT/RESET><+><->	$\Delta\theta_{df}$	5.3.7
Switch-over LED flash No LED flash	FLSH NOFL	<SELECT/RESET><+><->		5.3.8
Parameter switch/external triggering of the fault recorder	SET1, SET2, B_S2, R_S2, B_FR, R_FR, S2_FR	<SELECT/RESET><+><->	P2	5.3.9
Under voltage (low set) tripping delay of low set element	setting value in % setting value in seconds	<SELECT/RESET><+><-> one time for each value	U + 1 + < U + 1 + < + t>	5.4.1
Under voltage (high set) tripping delay of high set element	setting value in % setting value in seconds	<SELECT/RESET><+><-> one time for each value	U + 2 + < U + 2 + < + t>	5.4.1
overvoltage (low set) tripping delay of low set element	setting value in % setting value in seconds	<SELECT/RESET><+><-> one time for each value	U + 1 + > U + 1 + > + t>	5.4.1
overvoltage (high set) tripping delay of high set element	setting value in % setting value in seconds	<SELECT/RESET><+><-> one time for each value	U + 2 + > U + 2 + > + t>	5.4.1
frequency measuring repetition T	setting value in periods	<SELECT/RESET><+><->	f	5.4.2
frequency element f ₁ tripping delay of frequency element f ₁	setting value in Hz setting value in seconds	<SELECT/RESET><+><->	f + 1 + (> f + 1 + t>	5.4.3 5.4.4
frequency element f ₂ tripping delay of frequency element f ₂	setting value in Hz setting value in seconds	<SELECT/RESET><+><-> one time for each value	f + 2 + (> f + 2 + t>	5.4.3 5.4.4
frequency element f ₃ tripping delay of frequency element f ₃	setting value in Hz setting value in seconds	<SELECT/RESET><+><-> one time for each value	f + 3 + (> f + 3 + t>	5.4.3 5.4.4
response value for vector surge	Setting value in degrees	<SELECT/RESET><+><->	$\Delta\theta_{df}$	5.4.5
1-of-3/3-of-3 measurement	1Ph/3Ph	<SELECT/RESET><+><->	1/3_dt	5.4.5
setting value df/dt measuring repetition df/dt	setting value in Hz/s setting value in periods	<SELECT/RESET><+><-> one time for each value	$\Delta\theta_{df}$ 1/3_dt	5.4.5
Under voltage blocking of frequency and vector surge measuring (df/dt)	setting value in Volt	<SELECT/RESET><+><->	f, $\Delta\theta_{df}$	5.4.6
Over current I>	Setting value in %	<SELECT/RESET><+><-> one time for each value	I + 1 + >	5.5.1
Tripping characteristics for phase current	DEFT, NINV, VINV, EINV, LINV, RINV	<SELECT/RESET><+><-> one time for each value	I + 1	5.5.2
Tripping delay for I> or	Setting value in seconds	<SELECT/RESET><+><-> one time for each value	I + 1 + > + t>	5.5.3

Function	Display shows	Pressed pushbuttons required	Corresponding LED	Chapter
time factor for the characteristics	without unit			
Reset- Mode	0s/60s	<SELECT/RESET><+> <->	I + 1 + > + t>	5.5.4
Short circuit I>>	Setting value in %	<SELECT/RESET><+><->	I + 2 + >	5.5.5
Trip delay for I>>	Setting value in seconds	one time for each value	I + 1 + > + t>	
Residual voltage U0>	warn/trip	<SELECT/RESET><+><->	U ₀ + 1	5.6.4
Indication "Warning" or "Trip"				
Residual voltage U0>	Setting value in %	<SELECT/RESET><+><->	U ₀ + 1 + >	5.6.1
Trip delay for U0>	Setting value in seconds	one time for each value	U ₀ + 1 + > + t>	5.6.2
Residual voltage U0>>	Setting value in %	<SELECT/RESET><+><->	U ₀ + 2 + >	5.6.1
Trip delay for U0>>	Setting value in seconds	one time for each value	U ₀ + 2 + > + t>	5.6.2
Earth-over current IE>	Setting value in %	<SELECT/RESET><+><->	IE + 1 + >	5.6.3
		one time for each value		
Earth over current IE>	Warn/trip	<SELECT/RESET><+><->	IE + 1+2	5.6.4
indication Warning or Trip				
Tripping characteristic for earth current	DEFT, NINV, VINV, EINV, LINV, RINV, RXID	<SELECT/RESET><+><->	IE + 1	5.6.5
		one time for each value		
Tripping delay for IE>	Setting value in seconds	<SELECT/RESET><+><->	IE + 1 + > + t> + →	5.6.6
or		one time for each value		
time factor for the characteristics in forward direction	without unit			
Tripping delay for IE>	Setting value in seconds	<SELECT/RESET><+><->	IE + 1 + > + t> + ←	5.6.6
or		one time for each value		
time factor for the characteristics in reverse direction	without unit			
Reset- Mode	0s/60s	<SELECT/RESET><+> <->	IE + 1 + > + t>	5.6.7
Earth short-circuit IE>>	Setting value in %	<SELECT/RESET><+><->	I + 2 + >	5.6.8
Tripping delay for IE>>	Setting value in seconds	one time for each value	I + 2 + > + t> + →	5.6.9
in forward direction				
Earth short-circuit IE>>	Setting value in %	<SELECT/RESET><+><->	I + 2 + >	5.6.8
Tripping delay for IE>>	Setting value in seconds	one time for each value	I + 2 + > + t> + ←	5.6.9
in reverse direction				
switching over of isolated (sin φ) or compensated (cos φ) grids	SIN/COS	<SELECT/RESET><+> <->	IE + 1 + 2	5.6.10
Tripping delay of the C.B. failure protection	Setting value in seconds	<SELECT/RESET><+><->	CB + t>	5.7.1
		one time for each value		
Slave address of the serial interface	RS_1...RS32	<SELECT/RESET><+><->		5.7.2
		one time for each value		
Number of recorded sequences of events for MRG3; MRG3-U0;	1x10; 1x5; 2x5; 3x2. 4x2.; 7x1.; 8x1. (50Hz) 1x8.; 1x4.; 2x4.; 3x2. 4x2.; 7x1.; 8x1. (60Hz)	<SELECT/RESET><+><->	FR	4.8 5.8
		one time for each value		
Number of recorded sequences of events for MRG3-I; MRG3-IU0; MRG3-IER	1x20; 1x10; 2x10; 3x5; 4x5; 7x2.; 8x2. (50Hz) 1x16; 1x16; 2x8.; 3x4; 4x4.; 7x2.; 8x2. (60Hz)	<SELECT/RESET><+><->	FR	4.8 5.8
		one time for each value		
Trigger signal for the failure event recorder	TEST, P_UP, A_PI, TRIP	<SELECT/RESET><+><->	FR	4.8 5.8
		one time for each value		
pre-trigger period for the failure event recorder	Setting value in seconds	<SELECT/RESET><+><->	FR	4.8 5.8
		one time for each value		
Baud-Rate ¹⁾	2400-9600	<SELECT/RESET><+><->		5.7.3
		one time for each value		
Parity-Check ¹⁾	even/odd/no	<SELECT/RESET> <+><->		5.7.4
blocking of the protective function	BLOC, NO_B	<+> <-><SELECT/RESET>	U; f; Δθ/df; I; I _E ; U ₀ ; 1; 2; 3; <; >; CB	5.9.1

Function	Display shows	Pressed pushbuttons required	Corresponding LED	Chapter
relay assignment	____.1_3_ 2 3 4	<SELECT/RESET><+><-> one time for each value	L1; L2; L3; U; f; $\Delta\theta/df$; I; I _E ;U ₀ ; 1; 2; 3; <; >; CB	5.7.1
relay tripped at release of the C.B. failure protection	CBFP		L1; L2; L3; U; f; $\Delta\theta/df$; I; I _E ;U ₀ ; 1; 2; 3; <; >; CB	5.7.1
Enquiry failure memory	FLT1; FLT2.....	<-><+>	L1; L2; L3; U; f; $\Delta\theta/df$; I; E;U ₀	5.7.1
Delete failure memory	wait	<-> <SELECT/RESET> for 3s		5.7.1
Blocking	EXIT	<+> until max. setting value <-> until min. setting value	LED of blocked parameter	MR-allg.
Save parameter?	SAV?	<ENTER>		MR-allg.
Save parameter!	SAV!	<ENTER> for approx. 3 s		MR-allg.
Software Version	First part (e. g. D02-) Sec. part (e. g. 6.01)	<TRIP> one time for each part		MR-allg.
Manual trip	TRI?	<TRIP> 3 mal		MR-allg.
Inquire password	PSW?	<SELECT/RESET>/ <+><->/<ENTER>		MR-allg.
Relay tripped	TRIP	<TRIP> or fault tripping	L1; L2; L3; U; f; $\Delta\theta/df$; I; I _E ;U ₀ ; 1; 2; 3; <; >; CB	MR-allg.
Secret password input	XXXX	<SELECT/RESET>/ <+>/<->/<ENTER>		5.7.1
System reset	SEG	<SELECT/RESET> for about 3 s		5.7.1

1) only Modbus

Table 5.1: Possible indication messages on the display

5.2 Setting procedure

In this paragraph the settings for all relay parameters are described in detail. For parameter setting a password has to be entered first (please refer to 4.4 of description "MR-Digital Multifunctional Relays").

5.3 Systemparameters

5.3.1 Δ/Y – Change-over switch

Depending on the mains voltage conditions, the input voltage transformers can be operated in delta or Y connection. Changeovers are effected via the <+> and the <-> keys and stored with <ENTER>. (See chapter 4.3.1)

5.3.2 Display of measurement values as primary quantity

By means of this parameter it is possible to indicate measured values as primary values. For this purpose the parameter must be set to be equal with the rated primary CT current. If the parameter is set to "SEK", the measured value will be displayed as rated secondary CT voltage or as a multiple of the rated secondary CT current.

5.3.3 Setting of measured secondary values for the voltage transformers

By means of this parameter, the nominal secondary value of the voltage transformer has to be adjusted. If no voltage transformer is available, the parameter for "Indication of measured values as primary values on the display" has to be set to SEK (see chapter 5.3.2).

With the aid of this parameter, the MRG3 is capable of recognizing whether the calculation has to be based on 0 – 150 V or on the voltage range from 0 – 600V.

Upon adjustment of a rated secondary voltage of ≥ 138 V, all switching points of the measuring range 0 – 600 V will be calculated. If this parameter is set to ≤ 138 V, all switching points ranging from 0 – 150 V are calculated.

Please note: It has to be made sure that – for switching over to the different voltage ranges - the coding plugs are always properly plugged in (see chapter 3.1.8).

5.3.4 Setting of the generator's nominal values

Before the following parameters for the protective functions of current and voltage can be shown in percent, the nominal generator values for current and voltage have to be adjusted.

Example:

The generator has a nominal value of 8.2 kV. Voltage transformers with a rating of 10 kV/110 V are applied.

The resulting parameter settings are as follows:

rated primary CT voltage:	10 kV
rated secondary CT voltage:	110 V
rated generator voltage:	8.2 kV

If the generator is now operated at rated voltage, the measured voltage rating of "8k20" is displayed. If an under voltage step is then adjusted to 80%, there will be excitation at a generator voltage of $0.8 \times 8.2\text{kV} = 6.56$ kV.

The generator has a rated voltage of 180 A. Voltage transformers with a rating of 200 A/5A shall be applied.

Resulting from this, the parameter settings are as follows:

rated primary CT current: 0.20 kA
rated generator current: 0.18 kA

A parameter for the rated secondary CT current is not required since this parameter is equal to the rated current of the protective device.

If the over current step is now adjusted to 120%, there will be excitation at a generator voltage of $1.2 \times 180 \text{ A} = 216 \text{ A}$ and the display shows "k216".

5.3.5 Voltage transformer connection for residual voltage measuring (3pha/e-n/1:1)

Depending on the connection of the voltage transformer three possibilities of the residual voltage measurement can be chosen (see chapter 4.7.4).

5.3.6 Nominal frequency

The adapted FFT-algorithm requires the nominal frequency of the object to be protected as a parameter for correct digital sampling and filtering of the input currents.

By pressing <SELECT> the display shows "f=50" or "f=60". The desired nominal frequency can be adjusted by <+> or <-> and then stored with <ENTER>.

5.3.7 Selection between vector surge function or df/dt supervision

The MRG3 provides two methods for the supervision of short-term mains interruptions: the vector surge supervision (see chapter 4.5.2) and the df/dt supervision (refer to chapter 4.5.1)

The above indicated functions (vector surge = dPhi and df/dt supervision) can be selected by means of the arrow keys <+> and <-> .

5.3.8 Display of the activation storage

If after an activation of the relay, the existing current drops again below the pickup value, e.g. I>, without a trip has been initiated, LED I> signals that an activation has occurred by flashing fast.

The LED keeps flashing until it is reset again (push button <RESET>). Flashing can be suppressed when the parameter is set to NOFL.

5.3.9 Parameter changeover switch/external triggering of the fault recorder

By means of the parameter-change-over switches it is possible to activate two different parameter sets. Switching over of the parameter sets can either be done by means of software or via the external inputs RESET or blocking input. Alternatively, the external inputs can be used for Reset or blocking of the triggering of the fault recorder.

Software-parameter	Blocking input used as	RESET Input used as
SET1	Blocking input	RESET Input
SET2	Blocking input	RESET Input
B_S2	Parameter changeover switch	RESET Input
R_S2	Blocking input	Parameter change over switch
B_FR	Ext. triggering of the FR	Reset input
R_FR	Blocking input	Ext. triggering of FR
S2_FR	Parameter change-over switch	Ext. triggering of FR

Table 5.2: Function of the digital inputs

With the setting B_S2 the blocking input (D8, E8) is used as parameter-set change-over switch. With the setting R_S2 the reset input (D8, E8) is used as parameter-set change-over switch. With the setting B_FR the fault recorder is activated immediately by using the blocking input. On the front plate the LED FR will then light up for the duration of the recording. With the setting R_FR the fault recorder is activated via the reset input. With the setting S2_FR parameter set 2 can be activated via the blocking input and/or the fault recorder via the reset input. The relevant function is then activated by applying the auxiliary voltage to one of the external inputs.

Important note:

When functioning as parameter change over facility or used for external tripping, the external input RESET is not available for resetting. If, for example, the external blocking input is used as parameter set change-over switch, the protection functions must be separately blocked by the software (refer to chapter 5.7.1).

5.4 Protection parameter “Mains decoupling”

5.4.1 Parameter setting of “Over- and under voltage functions”

The setting procedure is guided by two colored LEDs. During setting of the voltage thresholds the LEDs U<, U<<, U> and U>> will be flashing up as follows:

```
U<    U + 1 + <
U<<   U + 2 + <
U>    U + 1 + >
U>>   U + 2 + >
```

When adjusting the related trip delay, the LEDs will be flashing up as follows:

```
tU<   U + 1 + < + t>
tU<<  U + 2 + < + t>
tU>   U + 1 + > + t>
tU>>  U + 2 + > + t>
```

Thresholds of the voltage supervision

During setting of the thresholds U<, U<<, U> and U>> the voltages of the generator rated voltage are directly displayed in %. The thresholds can be changed by the <+> <-> push buttons and stored with <ENTER>.

The under voltage supervision (U< and U<<) as well as the overvoltage supervision (U> and U>>) can be de-activated by setting the threshold to "EXIT".

Tripping delays of the voltage supervision

During setting of the tripping delays $t_{U<}$, $t_{U<<}$, $t_{U>}$ and $t_{U>>}$ the display shows the value directly in seconds. The tripping delay is changed via the push buttons <+> and <-> in the range of 0,04 s to 50 s and can be stored with the push button <ENTER>.

When setting the tripping delay to "EXIT" the value is infinite meaning only warning, no tripping.

Note:

When adjusting, the correct positioning of the coding plugs should again be checked (see chapter 3.1.8)

5.4.2 Number of measuring repetitions (T) for frequency functions

In order to avoid false tripping of the unit at short voltage drops of the system voltage or interference voltages, the MRG3 works with an adjustable measuring repetition counter. When the instantaneous frequency measuring value exceeds (at over frequency) or falls below (at under frequency) the set reference value, the counter is incremented, otherwise the counter is decremented down to the minimum value of 0. A trip alarm will only be given when the counter exceeds the value adjusted at T and after expiry of the frequency step's tripping delay.

The setting range for T is between 2 - 99.

Recommendation for setting:

For short tripping times, e.g. for machine protection or for mains decoupling T should be set in the range from 2 - 5.

At precision measurements, e.g. exact measurement of the system frequency a setting of T in the range from 5 - 10 is recommended.

5.4.3 Threshold values of frequency supervision

The frequency supervision of MRG3 has three frequency elements that are independent from each other. Depending on whether the pick-up value was set above or below the nominal frequency, these elements can be used for over- or for under frequency supervision.

Dependent on the preset nominal frequency f_N the pickup values from 30 Hz up to 70 Hz at $f_N = 50$ Hz and from 40 Hz to 80 Hz at $f_N = 60$ Hz can be set.

During setting of the pickup values $f_1 - f_3$ the display shows the values in Hz. A value of for instance 49,8 Hz is indicated with "4980".

The setting is accompanied by the following LEDs:

f_1 $f + 1 + <(>)$

f_2 $f + 2 + >(<)$

f_3 $f + 3 + >(<)$

If the rated frequency is exceeded or if it falls short, the ">" sign changes to "<" and vice versa.

The function of the individual frequency elements can be deactivated by setting the pickup values to "EXIT".

The setting value "EXIT" corresponds to the rated frequency.

5.4.4 Tripping delays for the frequency elements

Tripping delays $t_{f1} - t_{f3}$ of the three frequency elements can be independently set from $t_{f1min} - 300$ s.

The setting is accompanied by the following LEDs:

tf_1 $f + 1 + t>$

tf_2 $f + 2 + t>$

tf_3 $f + 3 + t>$

The minimum tripping delay tf_{1min} of the relay depends upon the number of set measuring repetitions T (periods) and amounts to:

T	$t_{f,min}$
2...49	$(T+1) \cdot 20$ ms
50...69	$(T - 49) \cdot 50$ ms + 1 s
70...99	$(T - 69) \cdot 100$ ms + 2 s

When setting the tripping delay to "EXIT" by pressing push button <+> up to the maximum setting value, the corresponding tripping relay is blocked. Pickup of the frequency element is however displayed on the front plate by the corresponding LED, an assigned alarm re-lay is also activated. This setting applies to 50 Hz and 60 Hz.

5.4.5 Parameter setting for vector surge supervision or frequency gradient speed

By means of the parameter for the selection between vector surge function or df/dt supervision (see chapter 5.3.7) it can be determined which of the two functions shall be enabled.

Parameter setting of vector surge supervision Both the vector surge angle $\Delta\Theta$ as well as the tripping logic concerning the vector surge have to be adjusted for a vector surge supervision.

If the tripping logic is set to 1-OFF-3 ("1Ph" on the display), the relay trips as soon as the measured vector surge angle has exceeded the set value $\Delta\Theta$ in one of the three phases. This is the more sensitive adjustment when compared with the three phase tripping logic

3-of-3 (= "3Ph" on the display), where tripping occurs only if the vector surge angle exceeds the set value in all three phases.

We recommend choosing the one phase tripping logic "1Ph". Only if this adjustment is too susceptible to interferences, adjustment "3Ph" should be used.

The recommended setting of the vector surge angle $\Delta\Theta$ in an efficient mains is 4 - 6 degrees. This setting is sufficient in most cases, because low impedance mains never have a vector surge greater than this value. In case of an auto reclosing, this value is considerably exceeded. In high impedance mains the setting should be 10° to 12° to avoid false tripping when switching on or switching off big consumer loads.

The vector surge function of this device can be checked as follows:

- a) Generator in isolated operation: Switching off and on of loads (approx. 20% of the nominal generator capacity) must trip the relay. Later in normal isolated operation the tripping of the relay is inhibited.
- b) In mains parallel operation switching on and switching off of user-defined consumer loads and adjustment of the prime mover's governor must not lead to tripping of the relay.

If possible the test described under a) and b) should be double checked by a real auto reclosing.

Threshold for the vector surge supervision

When the pickup value of the vector surge supervision is set, a value in angular degree is indicated at the display. The pickup value requested can be adjusted by pushbuttons <+> and <-> in the range of 2° to 22°. LED $\Delta\Theta_df$ lights up green during this setting. After adjustment of the sensitivity for 1Pha or 3 Pha, LED 1/3_dt will be flashing in red.

Parameter setting of frequency gradient speed

The pickup value of frequency gradient (parameter df) can be set between 0.2 to 10 Hz/s. The number of measuring repetitions (parameter dt) can be set between 2 - 64 cycles. This parameter defines the number of consecutive df/dt measurements, which have to exceed the set value, before tripping.

Setting information:

The power difference after mains failure causes a change in frequency, which can approximately be calculated as follows:

$$\frac{df}{dt} = -\frac{f_N}{T_A} \cdot \Delta P$$

with: f_N = rated frequency in Hz
 T_A = starting time at rated torque
 ΔP = per unit power deficit with reference to the rated active power of the generator

If the inertia time constant is known and a power difference given, the frequency gradient can be estimated by the a.m. equation. At a supposed power deficit of 20% and an inertia time constant of 10 s, the frequency gradient is 1 Hz/s.

To prevent false trippings at loading, deloading or failure signals, we would recommend a setting value for dt of minimum 4 cycles.

5.4.6 Voltage threshold value for frequency- and vector surge measuring resp. df/dt-measuring

Correct frequency measuring or vector surge measuring cannot be obtained if the system voltage is very low, for instance during generator start up or voltage failure. False tripping of the MRG3 in such cases is prevented by an adjustable voltage threshold U_B . If the system voltage is below this threshold, these functions of the relay are blocked.

During adjustment of U_B the LEDs f and $\Delta\theta/df$ light up.

5.5 Protection parameter “Over current”

5.5.1 Pickup value for phase over current element

When setting the pick-up value for this parameter, the setting value that appears on the display is related to the generator rated current in %. This setting is accompanied by LEDs I + 1 + >.

5.5.2 Time current characteristics for phase over current element

By setting this parameter, one of the following 6 messages appears on the display:

DEFT	-	Definite Time
NINV	-	Normal Inverse (type A)
VINV	-	Very Inverse (type B)
EINV	-	Extremely Inverse (type C)
RINV	-	RI-Inverse
LINV	-	Long Time Inverse

Any of these six characteristics can be changed by using <+> <->-push buttons and stored by means of the push button <ENTER>-.

5.5.3 Trip delay or time factor for phase over current element

After change of the tripping characteristic the LEDs I + 1 + > + t> for tripping time and time factor setting (t.) will flash up. This warning signal is an indication for the user to align the tripping time and/or the time factor to the modified operating mode and/or tripping time characteristic.

The warning signal continues flashing until the tripping time and/or time factor have been newly parameter-used.

If - within a period of 5 minutes (time for release of parameters) - new parameters were not entered by the user, the processor will automatically set tripping time and/or time factor to the most responsive adjustment value (lowest possible tripping time). When the time delay or the time multiplier is set out of range (Text "EXIT" appears on the display), the low set element of the over current relay is blocked. The "WARN"- alarm relay, however, remains activated.

After modification of the tripping characteristic, as a general rule, tripping time and time factor respectively, should be modified as well. To avoid improper combinations between tripping characteristic and tripping time respectively time factor, the proceeding is as follows:

Upon adjustment to the “Definite Time” tripping characteristic, the independent tripping time indicated in seconds (e.g. 0.35 = 0.35 seconds) will appear on the display. This tripping time can be gradually changed by means of the push buttons <+> <->. Upon setting of the definite time tripping characteristics, the time factor (tl>) appears on the display and LEDs I + 1 + > + t> light up. It can also be modified successively via push buttons <+> <->.

5.5.4 Reset mode for all tripping characteristics in the phase current path

To ensure tripping, even with recurring fault pulses shorter than the set trip delay, the reset mode for in-verse time tripping characteristics can be switched over. If the adjustment $I + 1 + > = 60s$, the tripping time is only reset after 60 s of faultless condition.

This function is not available if $I + 1 + > = 0$. With fault current cease the trip delay is reset immediately and started again at recurring fault current.

5.5.5 Pick-up value for high set element

The current setting value of this parameter is related to the generator's rated current of the relay and is indicated in %.

When the current setting for high set element is set out of range ("EXIT" appears on the display), the high set element of the over current relay is blocked.

The high set element can be blocked via terminals E8/D8 if the corresponding blocking parameter is set to bloc (refer to chapter 5.9.1).

5.5.6 Trip delay for high set element

Independent from the chosen tripping characteristic for $I >$, the high set element $I >>$ has always a definite-time tripping characteristic. An indication value in seconds appears on the display.

5.6 Parameter protection earth fault supervision

5.6.1 Pick-up value for residual voltage

Regardless of the preset earth current, an earth fault is only identified if the residual voltage exceeds the set reference value. This value is indicated in % of the generator rated voltage. For the relay version MRG3-IER, this protection has only a warning function; for the relay version MRG3-IU0 und MRG3-U0 it takes place in two steps and is accompanied by the following LEDs when being adjusted.

$U_0 >$ $U_0 + 1 + >$
 $U_0 >>$ $U_0 + 2 + >$

5.6.2 Trip delay for residual voltage (only MRG3-IU0 and MRG3-U0)

When setting the appropriate tripping delays, the LEDs will be flashing up as follows:

$t_{U0} >$ $U_0 + 1 + > + t >$
 $t_{U0} >>$ $U_0 + 2 + > + t >$

5.6.3 Pick-up value for earth fault element

For the relay version MRG3-IE, the setting values of this parameter relate to the earth current's apparent portion. The indicated value is shown as percentage of the generator's nominal earth fault current. For the relay version MRG3-IER, the indicated value relates to the effective portion of the earth current for compensated grids (cos.-procedure) or to the reactive portion for isolated grids and it is also displayed as percentage of the nominal earth current (see chapter 4.7.3)

The setting is accompanied by the LEDs $I_E + 1 + >$.

5.6.4 WARN/TRIP changing-over

(applies to MRG3-IE; MRG3-IU0 and MRG3-U0)

A detected earth fault can be parameterized as follows. After expiry of the delay time.

- the alarm relay responds "warn"
 - the tripping relay responds "trip" and the tripping values are stored.
- Upon this setting, the LEDs $I_E + 1$ or $U_0 + 1$ will be flashing.

5.6.5 Time current characteristics for earth fault element (only MRG3-IE)

By setting this parameter, one of the following 7 messages appears on the display:

DEFT	-	Definite Time
NINV	-	Normal inverse (type A)
VINV	-	Very inverse (type B)
EINV	-	Extremely inverse (type C)
RINV		RI-Inverse
LINV		Long time inverse
RXID		Special characteristic

Any of these characteristics can be chosen by using $<+>$ $<->$ -pushbuttons, and can be stored by using $<ENTER>$ -pushbutton. The setting is accompanied by the LEDs $I_E + 1 + >$.

5.6.6 Trip delay or time multiplier for earth fault element

(Similar to chapter 5.5.3).

Flashing of the LEDs IE + 1 + > + t> upon this setting.

Relay version MRG3-IER:

This version including directional feature allows different adjustment of the tripping time for forward and backward faults. For this purpose, the display first shows the up to date tripping time for forward faults. The LED that is marked by two arrows lights up in green. Thereafter, it is possible to change this forward setting value via push-buttons <+><-> and store it by pressing >ENTER>. After pressing the <SELECT> but-ton, the current setting value for backward faults is displayed. The LED that is marked by two arrows lights up in red.

This backward setting value should be higher than the value set for forward faults to allow the protective de-vice to operate selectively at occurrence of forward faults.

When setting tripping times for forward faults and backward faults to the same value, the relay will trip with the same time delay, i.e. without directional feature.

5.6.7 Reset mode for tripping characteristics in earth current path

(Similar to chapter 5.5.4).

Flashing of the LEDs IE + 1 + > + t> upon this setting

5.6.8 Pick-up value for earth faults resp. earth short circuit fast trips

(Similar to chapter 5.5.5).

Flashing of the LEDs IE + 2 + > upon this setting

5.6.9 Trip delay for earth fault s resp. earth short circuit fast trips

(Similar to chapter 5.5.6).

Flashing of the LEDs IE + 2 + > + t> upon this setting

5.6.10 COS/SIN-measurement

Depending on the neutral-point connection of the protected system the directional element for the earth current path must be preset to $\cos \varphi$ (isolated mains) or $\sin \varphi$ (compensated mains) measurement.

By pressing <SELECT> the display shows "COS" resp. "SIN". The desired measuring principle can be selected by <+> or <-> and must be entered with password. Flashing of the LEDs IE + 1 + 2 upon this parameterisation.

5.7 More Settings

5.7.1 Circuit breaker failure protection

The CB failure protection is based on supervision of phase currents during tripping events. Only after tripping this protective function becomes active. The test criterion is whether all phase currents are dropped to $< 2\% \times I_N$ within t_{CBFP} (Circuit Breaker Failure Protection). If not all of the phase currents have dropped to

$< 2\% \times I_N$ within this time t_{CBF} (adjustable between 0.1 –2.0s), a CB failure is detected and the related relay is activated. The CB failure protection function is deactivated again as soon as the phase currents have dropped to $< 2\% \times I_N$ within t_{CBFP} . The relay that is assigned the failure protection function will drop after expiry of no more than 2.54 s.

The LEDs CB + t> will be flashing upon this parameterisation.

5.7.2 Adjustment of the slave address

By pressing push buttons <+> and <-> the slave address can be set in the range of 1-32. The display shows RS1 to RS32

5.7.3 Setting of Baud-rate (applies for Modbus Protocol only)

Different transmission rates (Baud rate) from 2400 to 9600 Baud can be set for data transmission via Modbus protocol. The rate can be changed by push buttons <+> and <-> and saved by pressing <ENTER>.

5.7.4 Setting of parity (applies for Modbus Protocol only)

The following three parity settings are possible:

- „even“ = even
- „odd“ = odd
- „no“ = no parity check

The setting can be changed by push buttons <+> and <-> and saved by pressing <ENTER>.

5.8 Fault recorder

5.8.1 Adjustment of the fault recorder

The MRG3 is equipped with a fault recorder (see chapter 4.8. Three parameters can be adjusted.

5.8.2 Number of the fault recordings

The max. recording time is 20 s at 50 Hz or 16,66 s at 60 Hz.

The number of max. recordings requested has to be determined in advance. There is a choice of 1* 2, 3* 4 and 7* 8 recordings and dependent on this the duration of the individual fault recordings is defined, i.e.

Number of recordings				Rated frequency	Unit type
1*	1*/2	3*/4	7*/8		
20.00 s	10.00 s	5.00 s	2.50 s	50 Hz	MRG3; MRG3-U0
16.66 s	8.33 s	4.16 s	2.08 s	60 Hz	
10.00 s	5.00 s	2.50 s	1.25 s	50 Hz	MRG3-I; MRG3-IU0; MRG3-IE; MRG3-IER
8.33 s	4.16 s	2.08 s	1.04 s	60 Hz	

Table 5.3: Fault record duration

*The oldest record will be overwritten in case that the fault recorder is triggered although there is no more memory available.

If the respective partition was defined as not being over writeable and the maximal number of recorded disturbance events was assigned, the LED FR starts flashing (refer to chapters 4.8 und 5.10.10).

5.8.3 Adjustment of trigger occurrences

There is a choice between four different occurrences:

P_UP (Pickups)	Storage is initiated after recognition of a general activation.
TRIP	Storage is initiated after a trip has occurred.
A_PI (After Pickup)	Storage is initiated after the last activation threshold was fallen short of (recognizes e.g. circuit breaker failure protection).
TEST	Storing is activated by simultaneous actuation of the keys <+> and <->. During the recording time the display shows "Test".

5.8.4 Pre-trigger time

By the time T_{pre} it is determined which period of time prior to the trigger occurrence should be stored as well. It is possible to adjust a time between 0.05s and 1,25; 2,5 und 5s. With keys <+> and <-> the values can be changed and with <ENTER> be saved.

5.8.5 Adjustment of the clock

When adjusting the date and time, LED ☉ lights up. The adjustment method is as follows:

Date :	year	y=00
	month	m=00
	day	d=00

Time :	hour	h=00
	minute	m=00
	second	s=00

The clock starts with the set date and time as soon as the supply voltage is switched on. The time is safe-guarded against short-term voltage failures for at least 6 minutes.

Note:

The window for parameter setting of the clock is located behind the measuring value display. The parameter window can be accessed via the <SELECT/RESET> key.

5.9 Additional functions

5.9.1 Blocking of protection functions and assignment of the output relays

The blocking function of the MRG3 can be set according to requirement. By applying the aux. voltage to D8/E8, the functions chosen by the user are blocked. Setting of the parameter should be done as follows:

- When pressing push buttons <ENTER> and <TRIP> at the same time either the message "BLOC" (i.e. the respective function is blocked) or "NO_B" (i.e. the respective function is not blocked) are displayed. The LED that is allocated to the first protection function U< lights with U + 1 + <.
- By pressing push buttons <+> <-> the displayed value can be changed.
- The changed value is stored by pressing <ENTER> and entering the password.
- By pressing the <SELECT/RESET> push button, any further protection function which can be blocked is displayed.
- If the <SELECT/RESET> key is actuated again, the blocking menu is left and the assignment mode is accessed[^].

Function	Description	Display	LED
U<	Under voltage step 1	BLOC	U + 1 + <
U<<	Under voltage step 2	BLOC	U + 2 + <
U>	Overvoltage step 1	NO B	U + 1 + >
U>>	Overvoltage step 2	NO B	U + 2 + >
f1<(>)	Frequency step 1	BLOC	f + 1 + <(>)
f2<(>)	Frequency step 2	BLOC	f + 2 + <(>)
f3<(>)	Frequency step 3	NO B	f + 3 + <(>)
$\Delta\theta$	Vector surge	BLOC	$\Delta\theta$ df*
df/dt	Frequency changing rate	BLOC	$\Delta\theta$ df*
I>	Over current	NO B	I + 1 + >
I>>	Short circuit	BLOC	I + 2 + >
U ₀ >**	Residual voltage step 1	NO B	U ₀ + 1 + >
U ₀ >>**	Residual voltage step 2	NO B	U ₀ + 2 + >
I _E >	Earth current step 1	NO B	I _E + 1 + >
I _E >>	Earth current step 2	NO B	I _E + 2 + >
tCB	Circuit breaker failure protection	NO B	CB

* only one of the two functions can be activated

**not available in MRG3-IER

Table 5.4: Blockage function for two parameter sets

After the assignment mode has been activated, first the LEDs U + 1 + < light up. Now, up to four output relays can be assigned to the under voltage element U< as alarm relays. At the same time the selected alarm relays for under voltage element 1 are indicated on the display. Indication "1_ _" means that output relay 1 is assigned to this under voltage element. When the display shows " _ _ _", no alarm relay is assigned to this under voltage element. The assignment of output relays 1 - 4 to the current elements can be changed by pressing <+> and <-> push buttons. The selected assignment can be stored by pressing push button <ENTER> and subsequent input of the password. By pressing push button <SELECT/RESET>, LEDs U1 + 1 + < + t> lights up. The output relays can now be assigned to this voltage element as tripping relays. Relays 1 - 4 are selected in the same way as described before. By repeatedly pressing of the <SELECT/RESET> push button and assignment of the relays all elements can be assigned separately to the relays. The assignment mode can be terminated at any time by pressing the <SELECT/RESET> push button for some time (i.e. approx.. 3 s).

Note:

The function of jumper J2 that is described in the general description "MR Digital Multifunctional Relays" does not apply to the MRG3. For relays without assignment mode this jumper is used for parameter setting of alarm relays (activation at pickup or tripping).

- A form is attached to this description where the setting requested by the customer can be filled-in. This form is prepared for telefax transmission and can be used for your own reference as well as for telephone queries.

Relay function		Output relays				Display Indication	Corresponding LED
		1	2	3	4		
U<	Alarm					----	U + 1 + <
tU<	Tripping	X				1----	U + 1 + < + t>
U<<	Alarm					----	U + 2 + <
tU<<	Tripping	X				1----	U + 2 + < + t>
U>	Alarm					----	U + 1 + >
tU>	Tripping	X				1----	U + 1 + > + t>
U>>	Alarm					----	U + 2 + >
tU>>	Tripping	X				1----	U + 2 + > + t>
f1	Alarm					----	f + 1
tf1>	Tripping	X				1----	f + 1 + t>
f2	Alarm					----	f + 2
tf2>	Tripping	X				1----	f + 2 + t>
f3	Alarm					----	f + 3
tf3>	Tripping	X				1----	f + 3 + t>
$\Delta\theta$	Tripping	X				1----	$\Delta\theta_df^*$
df/dt	Tripping	X				1----	$\Delta\theta_df^*$
I>	Alarm					----	I + 1 + >
tI>	Tripping		X			2----	I + 1 + > + t>
I>>	Alarm					----	I + 2 + >
tI>>	Tripping		X			2----	I + 2 + > + t>
U ₀ >	Alarm					----	U ₀ + 1 + >
tU ₀ >	Tripping			X		..3	U ₀ + 1 + > + t>
U ₀ >>	Alarm					----	U ₀ + 2 + >
tU ₀ >>	Tripping			X		..3	U ₀ + 2 + > + t>
I _E >	Alarm					----	I _E + 1 + >
tI _E >	Tripping					..3	I _E + 1 + > + t>
I _E > →	Alarm					----	I _E + 1 + > + →
tI _E > →	Tripping					..3	I _E + 1 + > + t> + →
I _E > ←	Alarm					----	I _E + 1 + > + ←
tI _E > ←	Tripping					..3	I _E + 1 + > + t> + ←
I _E >>	Alarm				X	----	I _E + 2 + >
tI _E >>	Tripping				X	3	I _E + 2 + > + t>
I _E >> →	Alarm				X	----	I _E + 2 + > + →
tI _E >> →	Tripping				X	..3	I _E + 2 + > + t> + →
I _E >> ←	Alarm				X	----	I _E + 2 + > + ←
tI _E >> ←	Tripping				X	..3	I _E + 2 + > + t> + ←
tCB	Tripping				X	4	CB + t>

Table 5.5: Example of assignment matrix of the output relays (default settings)

(→) = forward direction;
 (←) = backward direction

This way, a tripping relay can be set for each activation and tripping direction.

5.10 Indication of measuring values

5.10.1 Measuring indication for mains decoupling

In normal operation the following measuring values for mains decoupling can be displayed:

In star connection:

- Voltage in phase L1 LED: U + L1
- Voltage in phase L2 LED: U + L2
- Voltage in phase L3 LED: U + L3

or, if delta connection was parameterized

- Voltage in phase L1/L2 LED: U + L1 + L2
- Voltage in phase L2/L3 LED: U + L2 + L3
- Voltage in phase L3/L1 LED: U + L3 + L1

- Frequency LED f
- Lowest frequency, measured before last reset LED: f + min
- Highest frequency, measured before last reset LED: f + max

- Vector surge in phase L1(L1/L2) LED: $\Delta\Theta/df + L1$
- Vector surge in phase L2(L2/L3) LED: $\Delta\Theta/df + L2$
- Vector surge in phase L3(L3/L1) LED: $\Delta\Theta/df + L3$
- Lowest vector surge, measured before last reset LED: $\Delta\Theta/df + \min$

or, if df/dt-function was activated

- Frequency gradient LED: $\Delta\Theta/df$
- Lowest frequency gradient, measured before last reset LED: $\Delta\Theta/df + \min$
- Highest frequency gradient, measured before last reset LED: $\Delta\Theta/df + \max$

5.10.2 Storage of min./max. values

The MRG3 offers each one minimum and one maximum storage values measured for frequency, vector surge and frequency gradient. These min./max. values are mainly used to appraise the network system's quality. Always the highest and lowest values of **each cycle** are measured and stored until the next reset (refer to chapter "Reset" 5.10.9).

Min./max.- frequency measuring:

The MRG3 ascertains the actual frequency from each cycle of the system voltage. These measuring values are entered into the min./max. storage. The latest entered min./max. values replace the previously stored values. Dependent on the adjustment of dt and tripping delay, it is possible that the stored min./max. values are considerably higher than the tripping threshold without causing a trip. The reason for this is the storage of instantaneous values.

Min./Max. measuring of the frequency gradient

The procedure described above applies also to the storage of min./max. values of df/dt measurement. Since each instantaneous df/dt value is stored, high values can occur which, however, do not cause any tripping.

This can for instance happen during switching procedures where high positive and negative df/dt values occur, but do not cause any tripping due to the special measuring method.

Min./max. measuring of the vector surge

The procedure described above applies also to storage of min./max. values of vector surge measuring. Since each instantaneous $\Delta\Theta$ value is stored, also here high values are possible which, however, do not cause any tripping.

These min./max. measurements are of great advantage for long-time analysis of the grid quality.

As to operation:

After each reset (refer to 5.10.9) the min./max. storages are cleared. As from this instant there is no time limit for the min./max. storage until the next reset. By repeatedly pressing the <SELECT/RESET> push button, the measuring values of the min./max. storage can be queried.

5.10.3 Unit of the measuring values displayed

The measuring values can optionally be shown in the display as a multiple of the "sek" rated voltage (xU_n) or as primary rated voltage. According to this the units of the display change as follows:

Indication as	Range	Unit
Secondary voltage	000V - 999V	V
Primary voltage	.00V – 999V	V
	1k00 – 9k99	kV
	10k0 – 99k0	kV
	100k – 999k	kV
	1M00 – 3M00	MV

Table 5.6: Units of the display

5.10.4 Indication of values measured for over current - and earth fault protection

During normal operation, the following measuring values for over current – and earth fault protection can be displayed.

Applies to MRG3-I, MRG3-IU0; MRG3-IE, MRG3-IER

- Current in phase L1 LED: I + L1
- Current in phase L2 LED: I + L2
- Current in phase L3 LED: I + L3

Applies to MRG3-IU0; MRG3-U0; MRG3-IER

- Residual voltage LED: U + E

Applies to MRG3-IE; MRG3-IER

- Earth current LED: E

Applies to MRG3-IER

- Active portion of the earth current LED: E + EP
- Reactive portion of the earth current LED: E + E_Q
- Angle between I_E and U_E LED: U + I + E

5.10.5 Units of the measuring values

The measuring values can optionally be shown in the display as a multiple of the "sek" rated value or as primary current. According to this the units of the display change as follows:

Phase current:

Indication as	Range	Unit
Secondary current	.000 – 40.0	x In
Primary current	.000 – 999.	A
	k000 – k999	kA*
	1k00 – 9k99	kA
	10k0 – 99k0	kA
	100k – 999k	kA
	1M00 – 2M00	MA

* for rated transformer current 2kA and up

Earth current

Indication as	Range	Unit
Secondary current	.000 – 15.0	x In
Active portion I_P	± 0.0 – 15	x In
Reactive portion I_Q	± 0.0 – 15	x In
Primary earth current	.000 – 999.	A
	k000 – k999	kA*
	1k00 – 9k99	kA
	10k0 – 99k0	kA
	100k – 999k	kA
	1M00 – 2M00	MA
Active portion I_P	± 0.0 – ± 999	A
	$\pm k00$ – $\pm k99$	kA*
	$\pm 1k0$ – $\pm 9k9$	kA
	$\pm 10k$ – $\pm 99k$	kA
	$\pm M10$ – $\pm M99$	MA
	$\pm 1M0$ – $\pm 2M0$	MA
Reactive portion I_Q	± 0.0 – ± 999	A
	$\pm k00$ – $\pm k99$	kA*
	$\pm 1k0$ – $\pm 9k9$	kA
	$\pm 10k$ – $\pm 99k$	kA
	$\pm M10$ – $\pm M99$	MA
	$\pm 1M0$ – $\pm 2M0$	MA

* for rated transformer current 2kA and up

Residual voltage

Indication as	Range	Unit
Secondary voltage	000V – 999V	V
Primary voltage	.000 – 999 V	kV
	1K00 – 9K99	kV
	10K0 – 99K9	kV
	100K – 999K	kV
	1M00 – 3M00	MV

5.10.6 Indication of fault data

All faults occurrences detected by the relay are indicated on the front plate optically. For this purpose, the MRG3 is equipped with the three LEDs (L1, L2, L3) and the function LEDs U, f, I, IE, U0, 1, 2, 3, <, >, t are equipped at MRG3. Not only fault messages are transmitted, the display also indicates the activated protection function. If, for example an overvoltage occurs, the corresponding phase LEDs L1 and/or L2 and/or L3 will light up as well as LEDs U + 1 + <. After expiry of the tripping time the LEDs are lit permanently. If the threshold of the respective protection function falls below the adjusted tripping time, this will be indicated by a short flashing up of the LEDs.

The display shows "TRIP" when the adjusted tripping time has expired. Then, it is possible to indicate the stored tripping values by pressing the push-button <SELECT/RESET> (see also chapter 4.1.1 of the MR – Digital Multi-function Relay)

5.10.7 Fault recorder

When the relay is energized or the relay has tripped, all fault data and times are stored in a non-volatile memory manner.

Excitation: The highest value measured during excitation phase is stored.

Tripping: All values measured at the moment of tripping are stored.

If an error is not immediately switched off after tripping, further fault data will be recorded.

The MRG3 is provided with a fault value recorder for max. 16 fault occurrences. In the event of additional trippings always the oldest data set is written over.

For fault indication not only the trip values are recorded but also the status of LEDs. Fault values are indicated when push buttons <-> or <+> are pressed during normal measuring value indication.

- Normal measuring values are selected by pressing the <SELECT/RESET> button.
- When then the <-> button is pressed, the latest fault data set is shown. By repeated pressing of the <-> button the last but one fault data set is shown etc. For indication of fault data sets abbreviations FLT1, FLT2, FLT3, ... are displayed (FLT1 means the latest fault data set recorded). At the same time the parameter set that was active at the occurrence is shown.
- By pressing <SELECT/RESET>, each individual measured fault value can be called up.
- By pressing <+> it can be scrolled back to a more recent fault data set. At first FLT8, FLT7, are always displayed.
- When fault recording is indicated (FLT1 etc.), the LEDs flash in compliance with the stored trip information, i.e. those LEDs which showed a continuous light when the fault occurred are now blinking to indicate that it is not a current fault condition. LEDs which were blinking during trip conditions, (element had picked up) just briefly flash.
- If the relay is still in trip condition and not yet reset (TRIP is still displayed), measuring values can not be shown.

Recorded fault data:

Measuring	Displayed value	Corresponding LED
Voltage	U_L1 U_L2 U_L3 in star connection U_L1/L2 U_L2/L3 U_L3/L1 in delta connection	U + L1 U + L2 U + L3 U + L1 + L2 U + L2 + L3 U + L3 + L1
Frequency	f f min f max	f f + min f + max
Vector surge	$\Delta\theta_L1(L1/L2)$ $\Delta\theta_L2(L2/L3)$ $\Delta\theta_L3(L3/L1)$	$\Delta\theta/df + L1$ $\Delta\theta/df + L2$ $\Delta\theta/df + L3$
Frequency changing rate	df	$\Delta\theta/df$
Phase current	I_L1 I_L2 I_L3	I + L1 I + L2 I + L3
Expired tripping time in % of $tI >$	$tI > \%$	I + 1 + > + t>
Residual voltage	U_0	U + E
Earth current Earth current active portion Earth current reactive portion	I_E $I_E_E_P$ $I_E_E_Q$	I_E $I_E + E_P$ $I_E + E_Q$
Expired tripping time in % of $tI_E >$	$tI_E > \%$	E + 1 + > + t>
Circuit breaker failure protection	tCBFP	CB + t>
Time stamp Date: Time:	Y = 99 M = 03 D = 10 h = 17 m = 21 s = 14	<input type="checkbox"/> <input type="checkbox"/> <input type="checkbox"/> <input type="checkbox"/> <input type="checkbox"/> <input type="checkbox"/>

Table 5.7: Fault data indications on display

Note:

It is only possible to call up those measuring values whose function was implemented in the respective de-vice version.

5.10.8 Erasure of fault storage

To delete stored fault records, the push button combination <SELECT/RESET> and <->, has to be pressed for about 3s. The display shows "wait".

5.10.9 Reset

All relays have the following four possibilities to reset the display of the unit and the output relay at jumper position J3=ON. (see also the description MR – Digital Multifunctional relay in chapter: 4.2.1 Function of the output relays)

Manual Reset

- By pressing the push button <SELECT/RESET> for some time (about 3 s)

External Reset

- Through applying auxiliary voltage to C8/D8

Software Reset

- The software reset has the same effect as the <SELECT/RESET> push button (see also communication protocol of RS485 interface)

Automatic Reset

- At each excitation of a protection function

The display can only be reset, when a pickup protection element is not present anymore (otherwise "TRIP" remains in display). During resetting of the display the parameters are not affected.

5.10.10 Delete of disturbance records

By repeated setting of the parameter "number of re-corded events", it is possible to delete data of the disturbance recorder. The LED FR will then expire (refer to chapter 5.8.2).

Alternatively, it is also possible to clear the memory space of the disturbance recorder by means of the software "HTL/PL-Soft4".

6. Maintenance and Commissioning

The test instructions following below help to verify the protection relay performance before or during commissioning of the protection system. To avoid a relay damage and to ensure a correct relay operation, make sure that:

- the auxiliary power supply rating corresponds to the auxiliary voltage on site.
- the rated current and rated voltage of the relay correspond to the plant data on site.
- the current transformer circuits and voltage transformer circuits are connected to the relay and
- that all signal circuits and output relays are connected correctly.

6.1 Connection of aux. voltage

Note!

Prior to switch on the auxiliary power supply, be sure that the auxiliary supply voltage corresponds with the rated data on the type plate.

Switch on the auxiliary power supply to the relay and check that the message "SEG" appears on the display and the self supervision alarm relay (watchdog) is energized (contact at terminals D7 and E7 closed).

It may happen that the relay is tripped because of under- voltage condition after power-on. In this case, "TRIP" is shown on the display and LEDs L1; L2; L3 will flash in order to indicate the trip phase as well as the LEDs for the cause of trip, namely LEDs U< + 1 + 2 + < for U< and/or U<<.

There are different possibilities to de-activate the two steps:

- Press the push button <ENTER>, thus entering into the setting mode. Now set the parameters U< and U<< to "EXIT" to block the under voltage functions. After that, press the <SELECT/RESET> for app. 3 s to reset the LEDs and "TRIP" message.
- The under voltage tripping after power on can also be eliminated by applying three phase rated voltages after power-on and reset the LED and "TRIP" message.
- Apply auxiliary voltage to the external blocking input (Terminals E8/D8) to inhibit the under voltage functions(refer to chapter 5.9.1). and press the <SELECT/RESET> for app. 3 s to reset the LEDs and "TRIP" message.

6.2 Testing of the output relays and LEDs

Prior to commencing this test, interrupt the trip circuit to the circuit breaker if tripping is not desired. By pressing the push button <TRIP> once, the display shows the first part of the software version of the relay (e.g. „D08-“). By pressing the push button <TRIP> twice, the display shows the second part of the software version of the relay (e.g. „4.01“. The software version should be quoted in all correspondence. Pressing the <TRIP> button once more, the display shows "PSW?". Please enter the correct password to proceed with the test. The message "TRI?" will follow. Confirm this message by pressing the push button <TRIP> again. All output relays should then be activated and the self supervision alarm relay (watchdog) be de energized one after another with a time interval of 1 second. Thereafter, reset all output relays back to their normal positions by pressing the push button <SELECT/RESET>.

6.3 Checking the set values

By repeatedly pressing the push button <SELECT>, all relay set values may be checked. Set value modification can be done with the push button <+><-> and <ENTER>. (For detailed information about that, please refer to chapter 4.5 of the description “MR – Digital multifunctional relays”.

Depending on the system conditions and the voltage transformer used, three voltages can be connected to the relay input circuits with either star or delta connection. In case of a star connection the phase-to-neutral voltage will be applied to the voltage input circuits, while the phase-to-phase voltages will be connected to the voltage input circuits in case of a delta connection. The voltage input connection must be set as a parameter, and should correspond with the actual voltage input connection:

Star connection: Phase-to-neutral voltages will be measured and evaluated.

Delta connection: Phase-to-phase voltages will be measured and evaluated.

To assure an efficient operation of the relay, the adjusted rated frequency ($f = 50/60$ Hz) has to be concordant with the system frequency (50 or 60 Hz).

6.4 Test with transformer secondary current (Secondary injection test)

6.4.1 Equipment required to test voltage functions

- Voltmeter and frequency meter, class 1 or better,
- Auxiliary voltage source supply suitable for the rated auxiliary voltage of the device.
- Three-phase alternating voltage source supply with adjustable frequency (voltage: adjustable from 0 to 2 x UN; frequency: adjustable from 40 - 70 Hz).
- Timer to measure the release time (Accuracy class ± 10 ms),
- Switching device and
- Test leads and tools.

For testing the vector surge function of the relay, a test circuit which can produce phase angle change (vector surge) is required to simulate mains failures (please refer to chapter 6.4.8). For testing the df/dt function of the relay, a special test equipment is required, which can produce a constant rate of change of frequency.

6.4.2 Test circuit

For testing the voltage functions of the MRG3-relay a three phase voltage source with adjustable voltage and frequency is required. Figure 6.1 shows an example of a three-phase test circuit energising the MRG3 relay during test. The three phase voltages are connected to the relay in Y-connection.

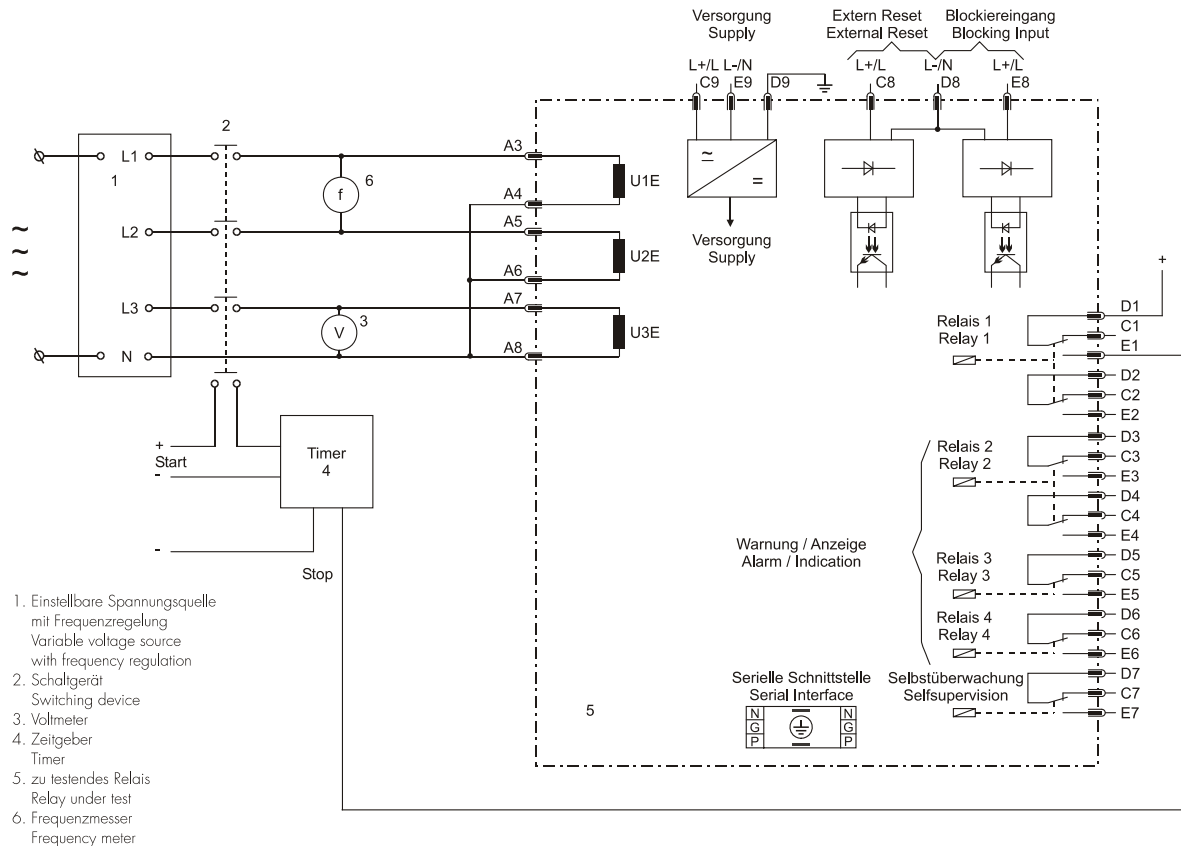


Figure 6.1: Three-phase test circuit for the voltage test

6.4.3 Checking of the input circuits and measuring functions

Apply three voltages of rated value to the voltage input circuits (terminals A3 - A8) of the relay. Check the measured voltages, frequency and vector surge on the display by pressing the push button <SELECT/RESET> repeatedly.

The displayed measuring voltages (shown in Volt) are dependent on the wiring of the input voltage converters and the settings of rated primary and secondary transformer voltage.

The voltages are indicated on the display in volts.

At Y-connection:

- Phase-to-neutral voltages: LEDs U and L1, L2 or L3
- Phase-to-phase voltages: LEDs U and L1+L2, L2+L3 or L1+L3

The frequency is indicated on the display in Hz: LED f (system frequency = 50.01Hz, Indication = 5001) The vector surge angle is indicated on the display in degrees LEDs $\Delta\theta/df$ (Indication in °) plus L1, L2 or L3. The rate of change of frequency (LED $\Delta\theta/df$) is indicated on the display in Hz/s. Example: 3.1 = 3.1 Hz/s.

Change the voltages around the rated value and check the measured voltages on the display. Change the system frequency around the rated frequency and check the measured frequency on the display.

When comparing the values indicated on the display with the indication of the measuring instruments, the voltage deviation must not exceed 1% or 0.3%/Un. and the frequency shall not deviate by more than 0.01 Hz.

By using an RMS-metering instrument, a greater deviation may be observed if the test voltage contains harmonics. Because the MRG3 relay measures only the fundamental component of the input signals, the harmonics will be rejected by the internal DFFT-digital filter. Whereas the RMS-metering instrument measures the RMS-value of the input signals.

6.4.4 Checking the pick-up and release values for over/under voltage

Note!

When the measuring voltage is connected or disconnected, vector surge tripping or df/dt tripping can occur. In order to ensure a trouble-free test procedure, the vector surge function or df/dt function of the relay have to be blocked before tests are started. Furthermore, attention must be paid that relays which are used for the alarm function, are assigned to the correct position (see chapter 5.9.1)

For the testing of response and release values, the test voltage has to be increased (decreased) until the relay is excited.

This is signaled by flashing of the LEDs U + 1(2) + <(>). The assigned alarm relay (e.g. contacts D4/E4) simultaneously picks up.

When comparing the values shown on the display to voltmeter values, the deviation must not be more than 1% of the measured value or 0.3% U_N .

Disengaging values can be detected by slowly in-creasing (decreasing) the test voltage until the output relay of U< (U>) drops.

Check that the dropout to pickup ratio for voltage is greater than 0.97 (for overvoltage function) or smaller than 1.03 (for under voltage).

6.4.5 Checking of the tripping delay time for over/under voltage

To check the relay's operating time, a timer must be connected to the trip output relay contact (Contact terminals D1/E1). The timer should be started simultaneously with the voltage change from sound condition to a faulty condition and stopped by the trip relay contact. The operating time measured by timer should have a deviation about 1%, of the set value or <20 ms.

6.4.6 Checking of the pick-up and release values for over/under frequency

Note!

Due to frequency changes, vector surge tripping or df/dt - tripping can occur during frequency tests. In order to ensure a trouble-free test procedure, the vector surge function or df/dt function of the relay have to be blocked before tests are started.

During frequency tests, each of the frequency elements should be tested separately. This makes it necessary that the other frequency elements of the relay have to be blocked by setting the frequency pickup values

$f_1 - f_3$ to "EXIT". For testing the pickup and dropout to pickup values, the test frequency has to be increased (decreased) until the relay is energized. This is indicated by lighting up of LEDs $f + 1 + <(>)$, $f + 2 + <(>)$ or $f + 3 + <(>)$.

When comparing the values displayed with those of the frequency meter, the deviation must not exceed 0.01 Hz. The dropout to pickup values are ascertained by increasing (decreasing) the test frequency slowly until the output relay releases.

The dropout to pickup value for over frequency must be >0.99 , and for under frequency <1.01 .

6.4.7 Checking of the tripping delay time for over/under frequency s

The tripping delay of the over/under frequency functions can be tested in the similar manner as in chapter 6.4.6 for over/under voltage functions.

6.4.8 Checking of the vector surge function

Note!

With the help of an advanced relay test equipment a phase shift (vector surge) on the voltage signal can be obtained to test the vector surge function of MRG3 re-lay. If there is no such testing facility available, a very simple simulation circuit may be used to test the vector surge function of the relay with a sufficient accuracy. Figure 6.2 shows the possibility to simulate a phase shift by means of a RC circuit. Closing or opening the switch S1 causes the phase angle of the input voltage to change depending on the adjustable resistance R.

The phase angle obtained may be calculated with the following formula and is almost independent on the test voltages.

In case of a 3-phase vector surge, the angle $\Delta\Theta$ can be calculated with the following formula if the parameters R_0 , R and C are known:

$$\Delta\Theta = \arctg \frac{1}{R_0 \omega \cdot C} - \arctg \frac{1}{(R_0 + R) \omega \cdot C}$$

Example: $R_0 = 1 \text{ Ohm}$, $R = 363 \text{ Ohm}$, $C = 3 \mu\text{F}$

then: $\Delta\Theta \cong 19^\circ$

Usually the voltage source impedance R_0 is negligible, hence R_0 may be assumed zero. Thus, the value of R may be calculated using the following simplified formula:

$$\Delta\Theta = 90^\circ - \arctg \frac{1}{R \cdot \omega \cdot C}$$

Note!

Using the above test circuit with single-phase vector surge, the resulting measured phase angle $\Delta\Theta$ is about half the value of $\Delta\Theta$ calculated for a 3-phase vector surge.

To make tripping possible during a one phase test procedure, the vector surge tripping has to be set to "1Ph".

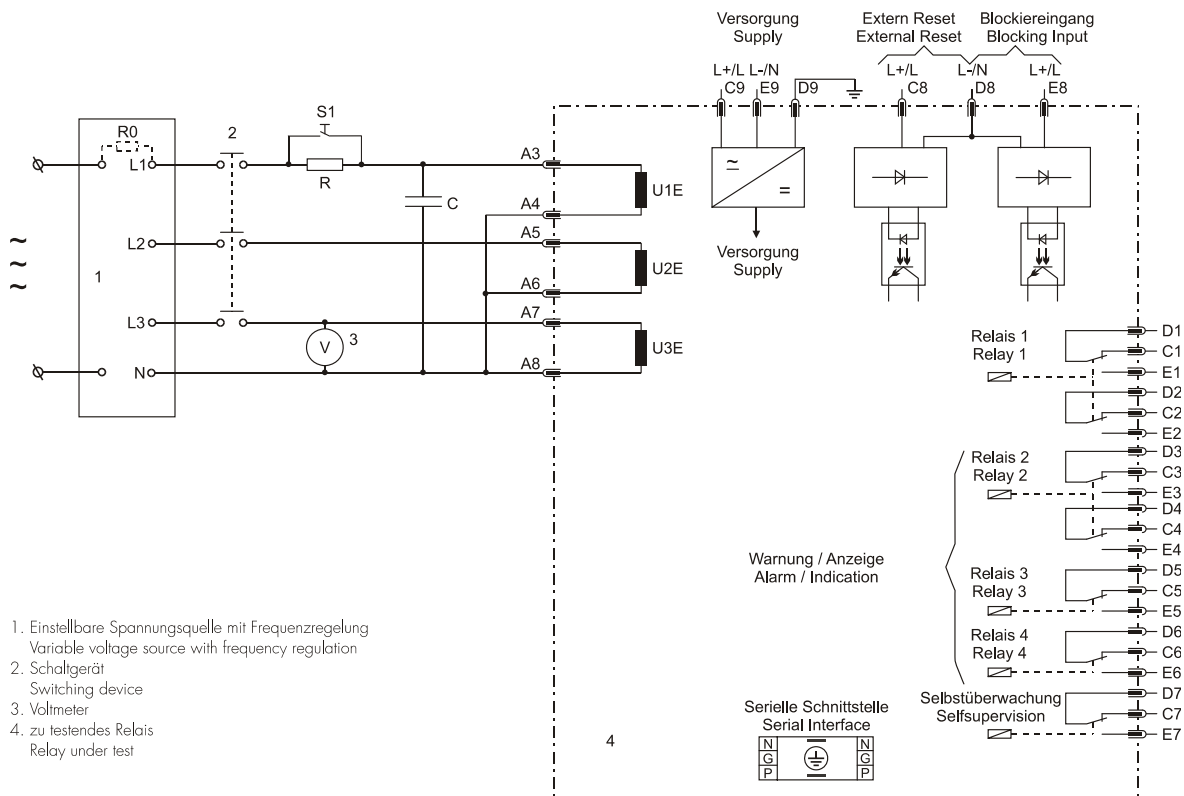


Figure 6.2: Test circuit for the vector surge function

6.5 Test with transformer secondary current (Secondary injection test)

6.5.1 Equipment required to test voltage functions

- Amperemeter and voltmeter, class 1 or higher,
- auxiliary voltage source supply with the voltage corresponding to the rated data on the type plate,
- single-phase alternating current source (adjustable from 0 to 4 x U_n)
- single-phase alternating current source (adjustable from 0 to 1.2 x U_n – only required for the relay version MRG3-IER with directional feature),
- timer to measure the operating time (Accuracy class ± 10 ms),
- switching device and measuring lead.

6.5.2 Test circuit for the current function

Only an adequate power source is required to test the MRG3-I. The below figure shows a simple example of a single-phase test circuit with controllable power source.

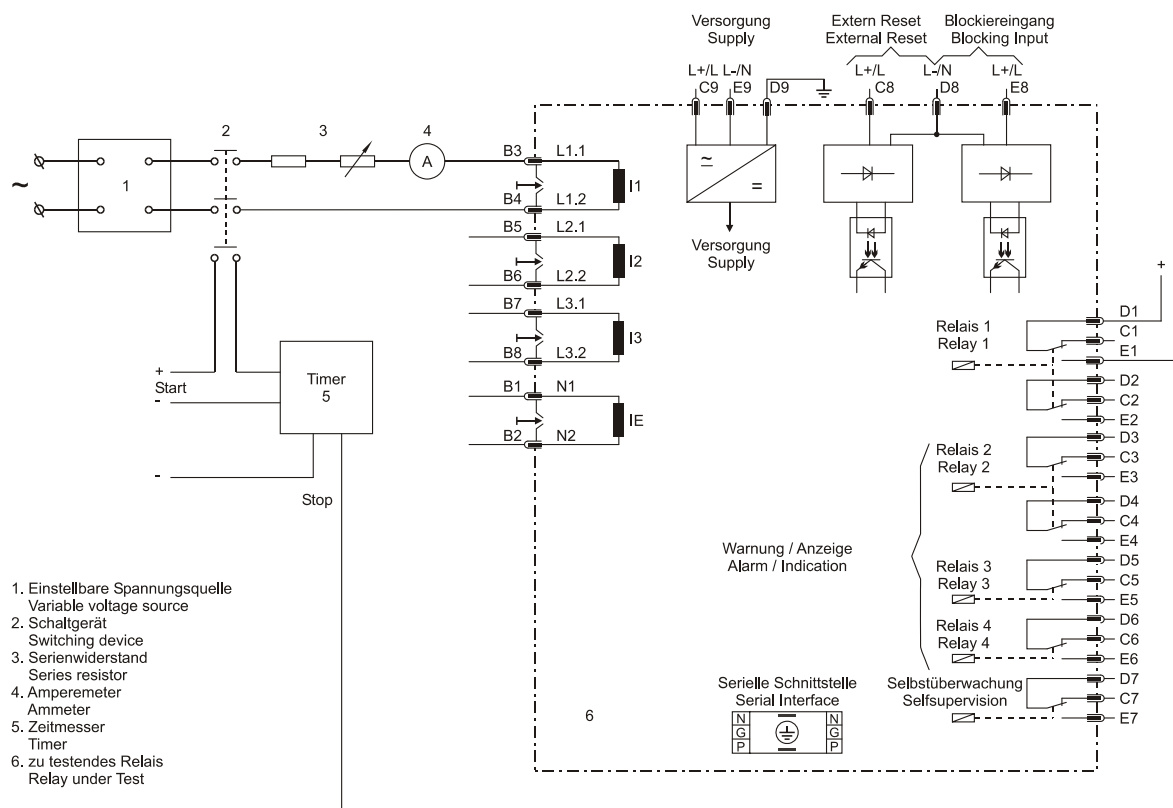


Figure 6.3: Test circuit for phase current test

6.5.3 Checking the input circuits and measured values

This test relates to the setting of parameters for the indication of measured values of secondary transformer currents. Impress a current, which is less than the relay pickup current set values, in phase 1 (terminals B3-B4). The measured current is displayed after repeatedly pressing the push button <SELECT>, when LEDs I and L1 are flashing. The thus indicated measured value can now be checked by means of an ammeter.

For a relay with rated current $I_n = 5A$, for example, a secondary current impression of 1A should be indicated on the display with about 0.2 ($0.2 \times I_n$). When parameter $I_{prim} = „SEK“$ is set, the indication is $0.2 \times I_n$ and at „5“ the indication is 1.00 [A]. The current can be also impressed into the other current input circuits (Phase 2: terminals B5-B6 with LEDs I + L2, Phase 3: terminals B7-B8 with LEDs I + L3. Compare the displayed current value with the reading of the ammeter. The deviation must not exceed 3% or 1% I_n . By using an RMS-metering instrument, a greater deviation may be observed if the test current contains harmonics. Because the MRG3-I relay measures only the fundamental component of the input signals, the harmonics will be rejected by the internal DFFT-digital filter. Whereas the RMS-metering instrument measures the RMS-value of the input signals.

6.5.4 Checking the operating and resetting values of the relay

Impress a current which is less than the relay set values in phase 1 of the relay and gradually increase the current until the relay starts, i.e. at the moment when the LED I> and L1 light up or the alarm output relay I> is activated. Read the operating current indicated by the ammeter. The deviation must not exceed 3% of the set operating value of the MRG3-I or 1% I_N . Furthermore, gradually decrease the test current until the relay resets, i.e. the alarm output relay I> is disengaged. Check that the resetting current is smaller than 0.97 times the operating current. Repeat the test on phase 2, phase 3 and earth current input circuits in the same manner. (Accuracy of earth current measuring $\pm 3\%$ of measuring value or 0.1% of I_N)

6.5.5 Checking of the tripping delay

To check the tripping delay, a timer must be connected to the trip contact of the output relay. The timer should be started simultaneously with the current injection in the current input circuit and stopped by the trip relay contact. Set the current to a value corresponding to twice the operating value and inject the current instantaneously. The operating time measured by the timer should have a deviation of less than 3% of the set value or ± 10 ms (DEFT). Accuracy for inverse time characteristics refer to EN60255-3

Repeat the test on the other phases or with the inverse time characteristics in the similar manner. In case of inverse time characteristics the injected current should be selected according to the characteristic curve, e.g. two times I_S . The tripping time may be read from the characteristic curve diagram or calculated with the equations given under "technical data". Please observe that during the secondary injection test the test current must be maintained stable (deviation $< 1\%$ since otherwise the test results might be distorted).

6.5.6 Checking the high set element of the relay

Set a current above the set operating value of short circuit element I>>. Impress the current instantaneously and check that the alarm output relay I>> is energized. When doing so, the over current step I> should be blocked before setting (it to EXIT). Check the tripping time of the high set element according chapter 6.5.5. Check the accuracy of the operating current setting by gradually increasing the impressed current until the I>> element picks up. Read the current value from the ammeter and compare with the desired setting. Repeat the entire test on other phases and earth current input circuits in the same manner.

Note !

Where test currents $> 4 \times I_N$ are used, the thermal with-stand capability of the current paths has to be considered (see technical data, chapter 7.3).

6.6 Example of a test circuit for MRG3-IER-relay with earth current directional feature

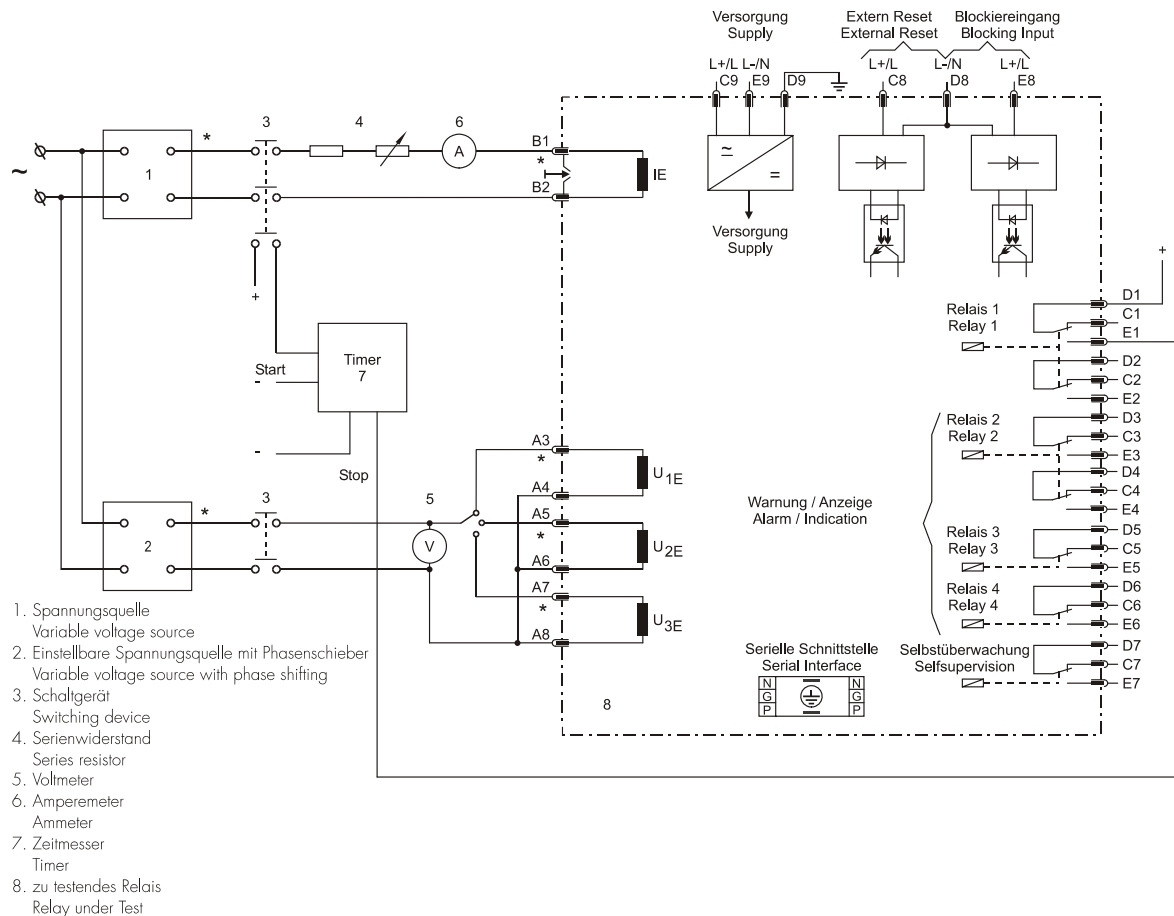


Figure 6.4: Test circuit for the testing of the earth directional element

For testing relay MRG3-IER with earth current directional feature, current and voltage source supplies with adjustable phase shifting are required. The phase position of the respective power source should be adjust-able.

Figure 6.4 shows an example of a single phase test circuit with adjustable voltage and current testing a re-lay with directional feature, one of the input voltage (terminals B1 – A2) shall be applied to the relay with a constant value within its effective range. The other input current (terminals B1 – B2) and phase angle shall be appropriately varied.

With the aid of phase angle indicated on the display the correct function of the relay MRG3-IER can be checked.

Parameters $I_{E>}$ and $I_{E>>}$ should be set to EXIT.

The following measured values are shown:

Measured value	related LED
earth current	E
active share	E + E _p
reactive share	E + E _Q
earth voltage	U + E
angle	U + E

6.7 Checking the external blocking and reset inputs

By means of the external blocking input, it is possible to block all protective functions. To give an example, the blocking function of the phase current high set element is described.

This can be tested by first setting the parameter for the phase current high set element (short circuit element) to „BLOC“ and then connecting the auxiliary voltage to terminals E8/D8.

The phase current low set element $I_{>}$ should be set to EXIT for this test. Inject a test current which could cause a high set ($I_{>>}$) tripping. Observe that there is no trip of any assigned output relay of the high set or low set element. Remove the auxiliary supply voltage from the blocking input. Inject a test current to trip the relay (message „TRIP“ on the display). Interrupt the test current and apply auxiliary supply voltage to the external reset input of the relay (terminals C8/D8). The display and LED indications should be reset immediately.

6.7.1 Test of the CB failure protection

For testing the tripping time a test current of about 2 times the rated current to be injected. The timer is started upon tripping of the relay of a protection function ($I_{>}$, $I_{>>}$, $I_{E>}$, $I_{E>>}$) and stopped as soon as the relay for the CB failure protection has picked up. Message "CBFP" is displayed and LEDs CB + t lights up. The tripping time ascertained by the timer should not deviate more than 1% or, at short trip delay, less than ± 10 ms from the set tripping time. Alternatively, the timer can be started when the aux. voltage and the test current are injected simultaneously. The timer stops when the corresponding output relay for circuit breaker failure protection trips. In this case the previously measured tripping delay has to be subtracted from the total tripping time measured.

6.8 Primary injection test

Generally, a primary injection test could be carried out in the similar manner as the secondary injection test described above. With the difference that the protected power system should be, in this case, connected to the installed relays under test "on line", and the test currents and voltages should be injected to the relay through the current and voltage transformers with the primary side energized. Since the cost and potential hazards are very high for such a test, primary injection tests are usually limited to very important protective relays in the power system.

Because of its powerful combined indicating and measuring functions, the MRG3 relay may be tested in the manner of a primary injection test without extra expenditure and time consumption. In actual service, for example, the measured current values on the MRG3 relay display may be compared phase by phase with the current indications of the ammeter of the switchboard to verify that the relay works and measures correctly.

6.9 Maintenance

Maintenance testing is generally done on site at regular intervals. These intervals vary among users depending on many factors: e.g. the type of protective relays employed; the importance of the primary equipment being protected; the user's past experience with the relay, etc.

For electromechanical or static relays, maintenance testing will be performed at least once a year according to the experiences. For digital relays like MRG3 this interval can be substantially longer. This is because:

- The MRG3- relays are equipped with very wide self-supervision functions, so that many faults in the relay can be detected and signaled during service. Important: The self-supervision output relay must be connected to a central alarm panel!
- The combined measuring functions of MRG3 relays enable supervision the relay functions during service.
- The combined TRIP test function of the MRG3 relay allows to test the relay output circuits.

A testing interval of two years for maintenance will, therefore, be recommended.

During a maintenance test, the relay functions including the operating values and relay tripping characteristics as well as the operating times should be tested.

7. Technical data

7.1 Measuring input voltage

Rated data:	Nominal voltage	U_N	100 V or 400 V see chapter 3.1.8 Code plugs
	Nominal frequency	f_N	50/60 Hz
Measuring range:	0 – 1.5 x U_N		
Measuring accuracy:	% from measuring value or 0.5% from rated value		
Power consumption in: voltage circuit	< 1 VA pro Phase bei U_N		
Thermal withstand capability in voltage circuit:	continuously	1.5 x U_N see chapter 3.1.8 Code plugs Blocking the frequency	
and vector surge measuring at under voltage:	adjustable (5% - 100% U)		
Dropout to pickup ratio:	$U > / U >> : > 99\%$	$U < / U << : < 101\%$	
Returning time:	60 ms		
Time lag error class index E:	±10 ms		
Minimum operating time:	40 ms		

7.1.1 Influences on the voltage measurement

Auxiliary voltage:	in the range of $0.8 < U_H / U_{HN} < 1.2$ no additional influences can be measured
Frequency:	Within the range from $0.9 < f / f_N < 1.1$, <0.2%/Hz, only the first harmonic is evaluated.

7.2 Frequency measurement

Rated data:	Rated frequency: 50Hz or 60Hz
Measuring range:	50Hz: 30 – 70Hz 60Hz: 40 – 80Hz
Measuring accuracy:	±0.03Hz
Dropout to pickup ratio:	$f > : > 99.95\%$ $f < : < 100.05\%$

7.2.1 Influences on the frequency measurement

Auxiliary voltage:	in the range of $0.8 < U_H / U_{HN} < 1.2$ No additional influences can be measured
Frequency:	no influences
Influences on delay times:	no additional influences can be measured

7.3 Measuring input: phase current

Rated data:	Nominal current I_N	1A or 5A
	Nominal frequency f_N	50/60 Hz adjustable
Measuring range:	0 – 40 x I_2	
Measuring accuracy:	±3% from measuring value or ±20mA	
Power consumption in:	at $I_N = 1$ A	0.2 VA
current circuit	at $I_N = 5$ A	0.1 VA
Thermal withstand capability in current circuit:	dynamic current withstand	
	(half-wave)	250 x I_N
	for 1 s	100 x I_N
	for 10 s	30 x I_N
	continuously	4 x I_N
Dropout to pickup ratio:	>97%	
Returning time:	40 ms	
Time lag error class index E:	±20 ms	
Minimum operating time:	40 ms	

7.3.1 Influences on the current measurement

Auxiliary voltage:	in the range of $0.8 < U_H/U_{HN} < 1.2$ No additional influences can be measured
Frequency:	Within the range from $0.9 < f/f_N < 1.1$; <0.2%/Hz, only the first harmonic is evaluated.
Influences on delay times:	no additional influences can be measured

7.4 Measuring input: Residual voltage

Rated data:	Nominal voltage U_N 100V or 400V see chapter 3.1.8 code plugs
Measuring range:	0 – 1.5 x U_N
Measuring accuracy:	2% from measuring value or 1% from rated value
Power consumption in voltage circuit:	< 1 VA per phase at U_N
Thermal withstand capability in voltage circuit:	continuously 1.5 x U_N see chapter 3.1.8 code plugs Dropout to pickup ration: $U_0>/U_0>>:>99%$
Returning time: ^	60 ms
Time lag error class index E:	±10 ms
Minimum operating time:	40 ms

7.4.1 Influences on the residual voltage measuring

Auxiliary voltage:	in the range of $0.8 < U_H/U_{HN} < 1.2$ no additional influences can be measured
Frequency:	Only the first harmonic is evaluated. Harmonic waves are suppressed.

7.5 Measuring input: Earth current

Rated data:	Nominal current I_N	1A or 5A
	Nominal frequency f_N	50/60 Hz adjustable
Measuring range:	MRG3-IE:	0 – 4.0 x I_N
	MRG3-IER:	0 – 0.5 x I_N
Measuring accuracy:	±3% from measuring value or ±20mA	
Power consumption in current circuit:	bei $I_N = 1$ A	0,2 VA
	bei $I_N = 5$ A	0,1 VA
Thermal withstand capability In current circuit:	dynamic current withstand (one halfwave)	
	for 1 s	250 x I_N
	for 10 s	100 x I_N
	continuously	30 x I_N
Dropout to pickup ratio:	MRG3-IE	95%
	MRG3-IER	97%
Returning time:	100 ms	
Minimum operating time:	100 ms	

7.5.1 Influences on the earth current measuring

Auxiliary voltage	in the range $0.8 < U_H/U_{HN} < 1.2$ no additional influences can be measured
Frequency:	Only the first harmonic is evaluated. Harmonic waves are suppressed.
Influences on delay times:	no additional influences can be measured

7.6 Common data

Fault recorder	
Recorded traces:	$i_{L1}, i_{L2}, i_{L3}, i_E, U_1, U_2, U_3, U_e$, frequency, 3*vector surge or $1 \cdot df/dt$
Sample time:	1.25 ms at 50 Hz 1.041 ms at 60 Hz
Storage capacity:	10 s (at 50 Hz) resp. 8.33 s (at 60 Hz)
Number occurrences:	1 occurrence from 5s (4.16s) 2 occurrences from 2.5s (2.08s) 4 occurrences from 1.25s (1.04s)

Admissible interruption of supply voltage without adverse effect on the relay's function: 50 ms

7.7 Output relays

The output relays have with the following characteristics:

Maximum breaking capacity: 250 V AC/1250 VA/continuous current 5 A

For DC voltage:

	ohmic	L/R = 40 ms	L/R = 70 ms
300 V DC	0.2 A/60 W	0.13 A/40 W	0.12 A/36 W
250 V DC	0.25 A/62 W	0.19 A/48 W	0.09 A/22 W
110 V DC	0.5 A/55 W	0.4 A/40 W	0.2 A/22 W
60 V DC	0.9 A/54 W	0.6 A/36 W	0.36 A/21 W
48 V DC	1.2 A/58 W	0.8 A/40 W	0.5 A/24 W
30 V DC	5 A/150 W	3.5 A/105 W	2.0 A/62 W

Minimum contact load:	24V DC 10mA
Mechanical life span:	10×10^6 operating cycles
Electrical life span:	1×10^5 operating cycles at 220 V AC/5 A
Contact material:	Silber-Cadmium-Oxyd (AgNI90/10)

Further technical data see general description „MR-Multifunctional relay“

7.8 Setting ranges and steps

7.8.1 System parameter

	Setting range	Step	(range)	Tolerance
Y/D	Interlinking of the voltage transformers Y= star connection D= delta connection			
U_L1 L2 L3_prim	(sek) 0.05...500kV Primary nominal transformer voltage	0.001 0.002 0.005 0.01 0.02 0.05 0.1 0.2 0.5 1 2	(0.05...0.20) (0.20...0.50) (0.50...1.00) (1.00...2.00) (2.00...5.00) (5.00...10.0) (10.0...20.0) (20.0...50.0) (50.0...100) (100...200) (200...500)	
U_L1 L2 L3_sec	1V.. 400V Secondary nominal transformer voltage	1 2	(1...150) (150...600)	Measured range 0 – 150V Measured range 150 – 600V Change-over via coding plugs (see chapter 3.1.8)
UN_I1 L2 L3	(sek) 0.05...500kV Primary nominal generator voltage	0.001 0.002 0.005 0.01 0.02 0.05 0.1 0.2 0.5 1 2	(0.05...0.20) (0.20...0.50) (0.50...1.00) (1.00...2.00) (2.00...5.00) (5.00...10.0) (10.0...20.0) (20.0...50.0) (50.0...100) (100...200) (200...500)	
I_L1 L2 L3_prim	(sek) 0.002... 50.0 kA Primary nominal transformer voltage	0.001 kA 0.002 kA 0.005 kA 0.01 kA 0.02 kA 0.05 kA 0.1 kA 0.2 kA	(0.002...0.200) (0.200...0.500) (0.500...1.00) (1.00...2.00) (2.00...5.00) (5.00...10.0) (10.0...20.0) (20.0...50.0)	
IN_L1 L2 L3	(sek) 0.002... 50.0 kA Primary nominal generator current in phase	0.001 kA 0.002 kA 0.005 kA 0.01 kA 0.02 kA 0.05 kA 0.1 kA 0.2 kA	(0.002...0.200) (0.200...0.500) (0.500...1.00) (1.00...2.00) (2.00...5.00) (5.00...10.0) (10.0...20.0) (20.0...50.0)	
U0_prim	(sek) 0.05...500kV Primary nominal transformer voltage for residual voltage	0.001 0.002 0.005 0.01 0.02 0.05 0.1 0.2 0.5 1 2	(0.05...0.20) (0.20...0.50) (0.50...1.00) (1.00...2.00) (2.00...5.00) (5.00...10.0) (10.0...20.0) (20.0...50.0) (50.0...100) (100...200) (200...500)	

	Setting range	Step (range)	Tolerance
U0_sek	100V.. 600V Secondary nominal transformer voltage for residual voltage	1 (100...150) 2 (150... 600)	Measured range 0 – 150V Measured range 150 – 600 V Change-over via coding plugs (see chapter 3.1.8) Fehler! Verweisquelle konnte nicht gefunden werden.
U0N_	(sek.) 0.05...500kV Primary nominal generator voltage for residual voltage	0.001 (0.05...0.20) 0.002 (0.20...0.50) 0.005 (0.50...1.00) 0.01 (1.00...2.00) 0.02 (2.00...5.00) 0.05 (5.00...10.0) 0.1 (10.0...20.0) 0.2 (20.0...50.0) 0.5 (50,0...100) 1 (100...200) 2 (200...500)	
IE_prim	(sek.) 0.002... 50.0 kA Primary nominal transformer current for earth fault	0.001 kA (0.002...0.200) 0.002 kA (0.200...0.500) 0.005 kA (0.500...1.00) 0.01 kA (1.00...2.00) 0.02 kA (2.00...5.00) 0.05 kA (5.00...10.0) 0.1 kA (10.0...20.0) 0.2 kA (20.0...50.0)	
IEN	0.01... 50.0 kA Primary nominal generator current for earth fault	0.001 kA (0.001...0.200) 0.002 kA (0.200...0.500) 0.005 kA (0.500...1.00) 0.01 kA (1.00...2.00) 0.02 kA (2.00...5.00) 0.05 kA (5.00...10.0) 0.1 kA (10.0...20.0) 0.2 kA (20.0...50.0)	
U0_IE	Method selected to measure residual voltage	3pha; e:n; 1:1	
fN	50Hz/60Hz	f=50; f=60	
$\Delta\Theta$, df/dt	Function selection: Vector surge or df/dt	dPhi; dfdt	
	Indication of activation storage	FLSH/NOFL	
P2	Selection parameter set/Function of the digital inputs	SET1; Set2; B_S2; R_S2; B_FR; R_FR; S2FR	

Table 7.1: System parameter

7.8.2 Parameter protection: Voltage protection, Frequency protection, Frequency gradient

	Setting range	Step	(range)	Tolerance
U< U<<	1...150 % (EXIT)	1	(1...150)	±1% of the set value or 0.5 % from U _N
tU< tU<<	0.04...300 s (EXIT)	0.02 0.05 0.1 0.2 0.5 1.0 2.0 5.0 10.0	(0.04...1.0) (1.0...2.0) (2.0...5.0) (5.0...10) (10...20) (20...50) (50...100) (100...200) (200...300)	±1% or ±25ms
U> U>>	U _N = 100 V: 1...150 % (EXIT)	1	(1...150)	±1% of the set value or 0.5 % from U _N
tU> tU>>	0.04...300 s (EXIT)	0.02 0.05 0.1 0.2 0.5 1.0 2.0 5.0 10.0	(0.04...1.0) (1.0...2.0) (2.0...5.0) (5.0...10) (10...20) (20...50) (50...100) (100...200) (200...300)	±1% or ±25 ms
T	T = 2...99 periods	1	(2...99)	
f1 - f3	30...49.99; EXIT; 50,01...70 Hz ¹ 40...59.99; EXIT; 60.01...80 Hz ²	0.1 0.01 0.01 0.1 0.1 0.01 0.01 0.1	(30.00...47.90) (48.00...49.99) (50.01...52.00) (52.10...70.00) (40.00...57.90) (58.00...59.99) (60.01...62.00) (62.10...80.00)	0.03 Hz
tf1 - tf3	t _{r,min} ³ ...300 s; EXIT	0.02 0.05 0.1 0.2 0.5 1.0 2.0 5.0 10.0	(0.06...1.0) (1.0...2.0) (2.0...5.0) (5.0...10.0) (10.0...20.0) (20.0...50.0) (50...100) (100...200) (200...300)	±1% or ±25 ms
df	0.2...10 Hz/s (EXIT)	0.1 0.2 0.5	(0.2...1.0) (1.0...5.0) (5.0...10.0)	0.1 Hz/s
dt	2...64 periods	1	(1...64)	
Δθ	2°...22° (EXIT)	1	(2...22)	±1°
1/3	1Ph/3Ph			
U _B <	5...100 %	1	(1...100)	±1% of the set value or 0.5 % from U _N

Table 7.2: Parameter protection: Voltage protection, Frequency protection, Frequency gradient protection

- 1) At 50 Hz Rated frequency
 2) At 60 Hz Rated frequency
 3) t_{r,min} min. relay operating time t_{r,min} = (T+1) x 20 ms

7.8.3 Time over current protection

	Setting range	Step	(range)	Tolerance
I>	20...400 % (EXIT)	1 2 5 10	(20...50) (50...100) (100...200) (200...400)	±3% of the set value or ±20mA
I_Char	Definite Time	DEFT		
tl>	0.04 - 260 s (EXIT) (definite time)	0.02 0.05 0.1 0.2 0.5 1.0 2.0 5.0 10.0	(0.04...1.0) (1.0...2.0) (2.0...5.0) (5.0...10) (10...20) (20...50) (50...100) (100...200) (200...300)	±3% or ±20 ms
I_Char	Normal Inverse Type "A" Very Inverse Type "B" Extremely Inverse Type "C" RI - Inverse Long Time Inverse	NINV VINV EINV RINV LINV		
	0.05 - 10 (EXIT) (inverse time)	0.01 0.02 0.05 0.1 0.2	(0.05...0.5) (0.5...1.0) (1.0...2.0) (2.0...5.0) (5.0...10.0)	±3% of the measuring value of the current or ±20ms (see EN 60255-3)
tl>Reset	Reset Mode for tripping times	0 s; 60 s		
I>>	20...400 % (EXIT)	1 2 5 10	(20...50) (50...100) (100...200) (200...400)	±3% of the set value or ±10 mA
tl>>	0.04...10 s (EXIT)	0.02 0.05 0.1 0.2 0.5 1.0 2.0 5.0 10.0	(0.04...0.5) (0.5...2.0) (2.0...5.0) (5.0...10.0) (10...20) (20...50) (50...100) (100...200) (200...300)	±3% or ±20 ms

Table 7.3: Time over current protection

7.8.4 Earth fault supervision

	Setting range	Step (Range)	Tolerance
$I_{E>}$	Warn or trip of $I_{E>}$ element	trip; warn	
$I_{E>}$	1...200 % (EXIT)	0.1 (1...5) 0.2 (5...10) 0.5 (10...20) 1 (20...50) 2 (50...100) 5 (100...200)	$\pm 3\%$ of the set value or. $\pm 0.3\% I_N$
$tI_{E>}$	0.04 - 300 s (EXIT) (definite time)	0.02 (0.06...1.0) 0.05 (1.0...2.0) 0.1 (2.0...5.0) 0.2 (5.0...8.5) 0.5 (10...20) 1,0 (20...50) 2.0 (50...100) 5.0 (100...200) 10.0 (200...300)	$\pm 3\%$ or ± 20 ms
I_{E_Char}	Normal Inverse Typ "A" Very Inverse Typ "B" Extremely Inverse Typ "C" RI - Inverse Long Time Inverse RXIDG-Kennlinie	NINV VINV EINV RINV LINV RXID	
	0,05 - 10 (EXIT) 0.05 – 1.0 (EXIT) only RXIDG (inverse time)	0.01 (0.05...0.5) 0.02 (0.5...1.0) 0.05 (1.0...2.0) 0.1 (2.0...5.0) 0.2 (5.0...10.0)	$\pm 3\%$ related to the measured current value and ± 20 ms re- spectively (see EN 60255-3)
$tI_{E>}$ Reset	Reset Mode for tripping times	0s; 60s	
$I_{E>>}$	1...400 % (EXIT)	0,1 (1...5) 0,2 (5...10) 0,5 (10...20) 1 (20...50) 2 (50...100) 5 (100...200) 10 (200...400)	$\pm 3\%$ of the set value
$tI_{E>>}$	0.04...300 s (EXIT)	0.02 (0.06...0.5) 0.05 (0.5...2.0) 0.1 (2.0...5.0) 0.2 (5.0...10) 0.5 (10...20) 1.0 (20...50) 2.0 (50...100) 5.0 (100...200) 10.0 (200...300)	$\pm 3\%$ or ± 20 ms

Table 7.4: Earth fault supervision

7.8.5 Earth fault supervision with directional feature

	Setting range	Step (range)	Tolerance
U0>	3pha: 1 – 86% e-n: 1 - 86 % 1:1: 1 - 150 %	1 (1...150)	±2% of the set value or 1 % from U _N
I _E >	1...45 % (EXIT)	0.1 (1...5) 0.2 (5...10) 0.5 (10...20) 1 (20...45)	±3% of the set value or ±0.3% I _N
tI _E >V* tI _E >R**	0,1 - 300 s (EXIT) (definite time)	0.1 (0.1...5.0) 0.2 (5.0...10.0) 0.5 (10...20) 1.0 (20...50) 2.0 (50...100) 5.0 (100...200) 10.0 (200...300)	±3% bzw. ±80 ms
I _E >>	1...45 % (EXIT)	0.1 (1...5) 0.2 (5...10) 0.5 (10...20) 1 (20...45)	±3% of the set value or ±0.3% I _N
tI _E >>V* tI _E >>R**	0.1... 300 s (EXIT)	0.1 (0.1...5.0) 0.2 (5.0...10.0) 0.5 (10...20) 1.0 (20...50) 2.0 (50...100) 5.0 (100...200) 10.0 (200...300))	±3% or ±80 ms

Table 7.5: Earth fault supervision with directional feature

* Tripping time in forward direction (tripping range)

** Tripping time in backward direction (blocking range), see chapter 4.7.3

7.8.6 Determination of the earth fault direction (MRG3-IER)

Measurement of the energy component of current in compensated grids:

$$I_E \times \cos \varphi$$

Measurement of the reactive current component in isolated grids:

$$I_E \times \sin \varphi$$

Accuracy of angular measurement:

$$\pm 3^\circ \text{ at } I_E \times \cos \varphi \text{ bzw. } I_E \times \sin \varphi > 5\% I_E$$

Sensitive of the residual voltage:

$$> 2\% U_{0N} \text{ bei } I = 0.1 \times I_{EN}$$

7.8.7 Residual voltage protection

	Setting range	Step	Tolerance
U ₀ >	e-n: 1 - 86% 1:1: 1 - 150 %	1 (1...150)	±2% of the set value or 1 % from U _N
U ₀ >	Warning or tripping of the I ₀ > element	trip; warn	
tU ₀ >	0.1...50 s (EXIT)	0.02 (0.04...1.0) 0.05 (1.0...2.0) 0.1 (2.0...5.0) 0.2 (5.0...10) 0.5 (10...20) 1.0 (20...50) 2.0 (50...100) 5.0 (100...200) 10.0 (200...300)	±1% or ±20ms
U ₀ >>	e-n: 1 - 70 % 1:1: 1 - 120 %	1 (1...120)	±2% of the set value or 1 % from U _N
tU ₀ >>	0.04...300 s (EXIT)	0.02 (0.04...1.0) 0.05 (1.0...2.0) 0.1 (2.0...5.0) 0.2 (5.0...8.5) 0.5 (10...20) 1.0 (20...50) 2.0 (50...100) 5.0 (100...200) 10.0 (200...300)	±1% or ±20ms

Table 7.6: Residual voltage protection

7.8.8 CB failure protection

LED	Setting range	Step (range)	Tolerance
tCBFP>	0.1...2.00s (EXIT)	0.02 (0.10...1.00) 0.05 (1.00...2.00)	

Table 7.7: CB failure protection

7.8.9 Interface parameter

Function	Parameter	Modbus protocol	RS485 Open Data Protocol
RS	Slave address	1 - 32	1 - 32
RS	Baud-Rate*	2400, 4800, 9600	9600 (fixed)
RS	Parity*	even, odd, no	„even Parity“ (fixed)

Table 7.8: Interface parameter

* only Modbus protocol

7.8.10 Parameter for the fault recorder

Function	Parameter	Number of recordings				Rated frequency
FR	Applicable for MRG3; MRG3-U0	1*	1*/2	3*/4	7*/8	50 Hz
		20.00 s	10.00 s	5.00 s	2.50 s	60 Hz
	Pre-Trigger-time	16.66 s	8.33 s	4.16 s	2.08 s	60 Hz
		0.1 s – maximum 20.00 s				50 Hz
	Applicable for MRG3-I; MRG3-IU0, MRG3-IE; MRG3-IER	0.1 s – maximum 16.66 s				60 Hz
		10.00 s	5.00 s	2.50 s	1.25 s	50 Hz
		8.33 s	4.16 s	2.08 s	1.04 s	60 Hz
		Pre-Trigger-time				50 Hz
Pre-Trigger-time	0.1 s – maximum 10.00 s				50 Hz	
	0.1 s – maximum 8.33 s				60 Hz	
FR	Storage of recording at occurrence of an event	P_UP; TRIP; A_PI; TEST				

7.9: Parameter for the fault recorder

* Upon reservation of all storage places; a new trigger alarm will be given and the latest recorded event is written over.

7.8.11 Output relay

Relay type	Number of relays/change-over contacts	Number of relays/change-over contacts
MRG3	2/2	3/1

7.10: Output relay

7.8.12 Inverse time over current protection relay

According to IEC 255-4 or BS 142

Normal Inverse (Type A)

$$t = \frac{0.14}{\left(\frac{I}{I_s}\right)^{0.02} - 1} \cdot t_{I>} [s]$$

Very Inverse (Type B)

$$t = \frac{13.5}{\left(\frac{I}{I_s}\right) - 1} \cdot t_{I>} [s]$$

Extremely Inverse (Type C)

$$t = \frac{80}{\left(\frac{I}{I_s}\right)^2 - 1} \cdot t_{I>} [s]$$

Long Time Inverse

$$t = \frac{120}{\left(\frac{I}{I_s}\right) - 1} \cdot t_{I>} [s]$$

RI-Inverse Time

$$t = \frac{1}{0.339 - \frac{0.236}{\left(\frac{I}{I_s}\right)}} \cdot t_{I>} [s]$$

*RXIDG – characteristic

$$t = \left(5.8 - 1.35 \cdot \ln \left(\frac{I}{I_s \cdot t_{I>}} \right) \right) [s]$$

Where:

t	=	tripping time
t _{I>}	=	time multiplier
I	=	fault current
I _s	=	Starting current
ln	=	natural logarithm

*only for earth current

7.9 Inverse time characteristics

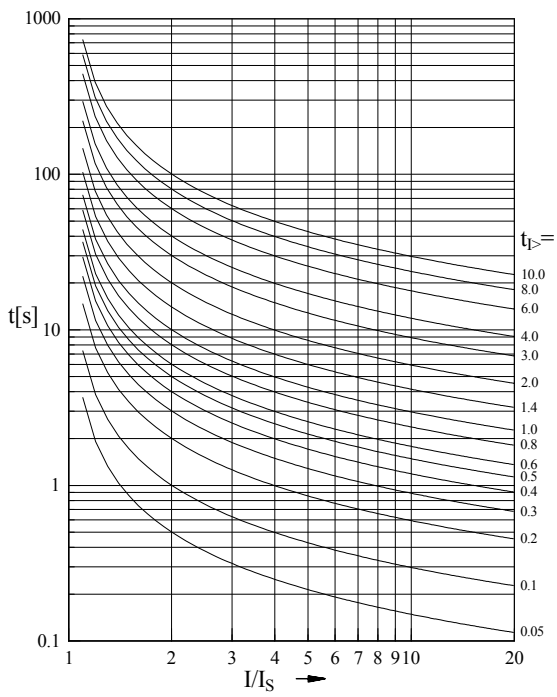


Figure 7.1: Normal Inverse (Typ A)

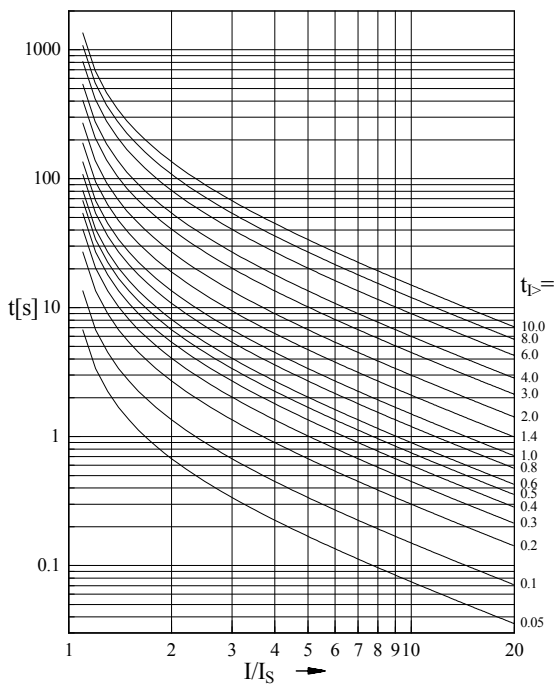


Figure 7.2: Very Inverse (Typ B)

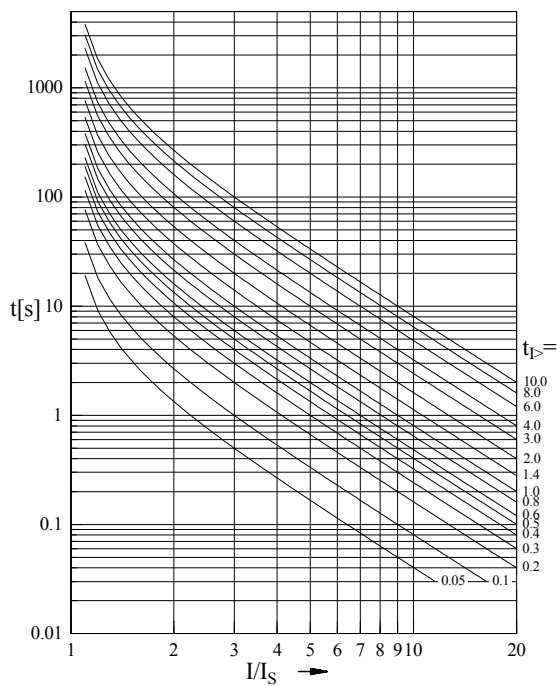


Figure 7.3: Extremely Inverse (Typ C)

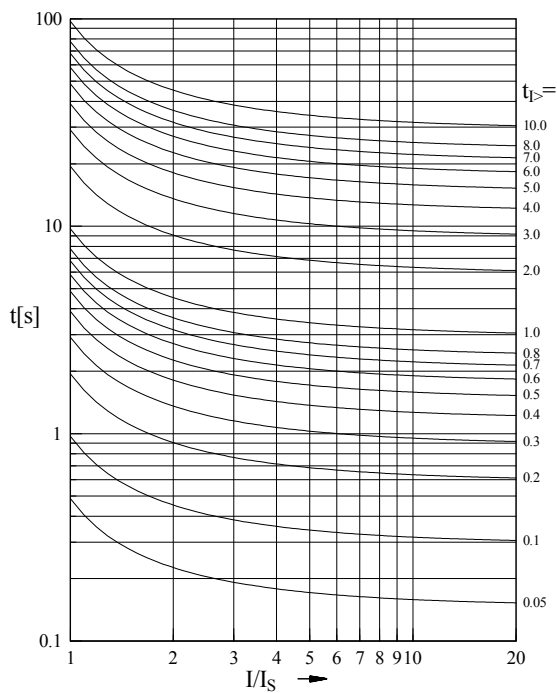


Figure 7.4: RI-Inverse

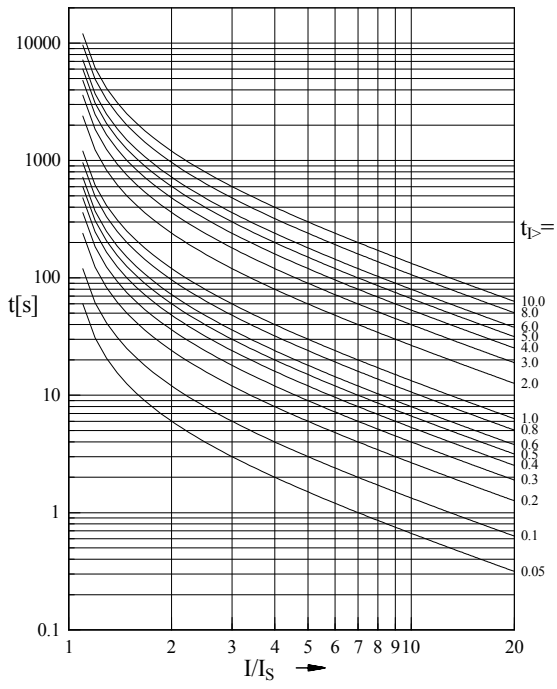


Figure 7.5: Long Time Inverse

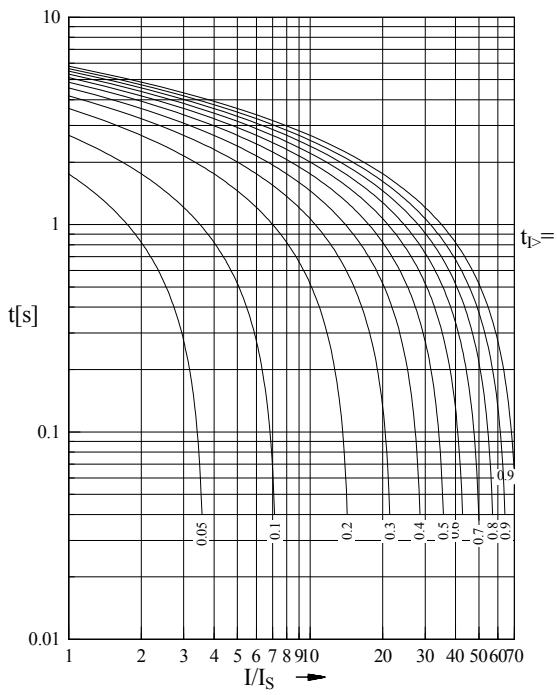


Figure 7.6: RXIDG-characteristic

8. Order form

Generator protection relay with voltage, frequency, vector surge- and df/dt-supervision		MRG3-				
Time overcurrent protection			*			
Phase current	1 A rated current	I1				
	5 A rated current	I5				
Earth fault protection ¹			*			
Earth current	1 A rated current	E1				
	5 A rated current	E5				
Residual voltage		U0				
Directional feature in earth path ¹				*		
Residual voltage supervision				R		
Housing (12TE)	19"-rack				A	
	Flush mounting				D	
Communication protocol RS485 Pro Open Data; MODBUS RTU						* -M

* Please leave box empty if option is not desired

¹ (only in combination with time over current protection)

Technical data subject to change without notice!

Setting list MRG3

Note !

All settings must be checked at site and should the occasion arise, adjusted to the object/item to be protected.

Project: _____ SEG job.-no.: _____

Function group: = _____ Location: + _____ Relay code: - _____

Relay functions: _____ Password: _____

Date: = _____

Adjustment of the parameter

Adjustment of date and time

			Relay type						Actual settings
Symbol /LED	Function		MRG3	MRG3-I	MRG3-UO	MRG3-IE	MRG3-IOU	MRG3-IER	
				Year settings	Year	x	x	x	
	Month settings	Month	x	x	x	x	x	x	M=01
	Day settings	Day	x	x	x	x	x	x	D=01
	Settings of the hours	Hours	x	x	x	x	x	x	h=00
	Settings of the minutes	Minutes	x	x	x	x	x	x	m=00
	Setting of the seconds	Seconds	x	x	x	x	x	x	s=00

System parameter

				Relay type						Default settings	Actual settings
Symbol	LED	Function	Unit	MRG3	MRG3-I	MRG3-U0	MRG3-IE	MRG3-IU0	MRG3-IER		
Δ/Y	U+L1+L2+L3	Input voltage correction dependent on the connection of the input transformer		X	X	X	X	X	X	Y	
U_L1 L2 L3_prim	U+L1+L2+L3+1	Primary nominal transformer voltage	kV	X	X	X	X	X	X	sek	
U_L1 L2 L3_sec	U+L1+L2+L3+2	Secondary nominal transformer voltage	V	X	X	X	X	X	X	400	
U_L1 L2 L3 rated	U+L1+L2+L3+3	Primary nominal generator voltage	kV	X	X	X	X	X	X	sek	
I_L1 L2 L3_prim	I+L1+L2+L3+1	Primary nominal transformer voltage in phase	kA		X		X	X	X	sek	
I_L1 L2 L3 rated	I+L1+L2+L3+2	Primary nominal generator voltage in phase	kA		X		X	X	X	sek	
U ₀ _prim	U+E+1	Primary residual voltage	kV			X		X	X	sek	
U ₀ _sec	U+E+2	Secondary nominal transformer voltage for the residual voltage	V			X		X	X	400	
U ₀ _rated	U+E+3	Primary nominal value for residual voltage	kV			X		X	X	sek	
I _E _prim	I+E+1	Primary nominal transformer current for earth fault	kA		X		X		X	sek	
I _E _rated	I+E+2	Primary nominal value for earth fault	kA		X		X		X	sek	
U ₀ _meas	U+E	Method selected to the measure residual voltage				X		X	X	e:n	
f _N		Nominal frequency	Hz	X	X	X	X	X	X	50 Hz	
$\Delta\theta/df/dt$	$\Delta\theta/df$	Selection of the mains decoupling function		X	X	X	X	X	X	$\Delta\theta$	
LED Flash		Flashing upon excitation		X		X	X	X	X	FLSH	
P2	P2	2 parameter sets/external triggering for FR		X		X	X	X	X	SET1	

Protection parameters: Mains decoupling

Symbol	LED	Function	Unit	Relay type						Default settings Set 1 Set 2	Actual settings Set1 Set 2
				MRG3	MRG3-H	MRG3-U0	MRG3-IE	MRG3-IU0	MRG3-IER		
U<	U+1+<	Pickup value for the 1 st under voltage element (low set)	%	X	X	X	X	X	X	90	
t _u <	U+1+<+t>	Tripping delay for the 1 st under voltage element	s	X	X	X	X	X	X	0.04	
U<<	U+2+<	Pickup value for the 2 nd under voltage element (high set)	%	X	X	X	X	X	X	80	
t _u <<	U+2+<+t>	Tripping delay for the 2 nd under voltage element	S	X	X	X	X	X	X	0.04	
U>	U+1+>	Pickup value for the 1 st overvoltage element (low set)	%	X	X	X	X	X	X	110	
t _u >	U+1+>+t>	Tripping delay for the 1 st overvoltage element	S	X	X	X	X	X	X	0.04	
U>>	U+2+>	Pickup value for the 2 nd overvoltage element (high set)	%	X	X	X	X	X	x	120	
t _u >>	U+2+>+t>	Tripping delay for the 2 nd overvoltage element	S	X	X	X	X	X	X	0.04	
T	f	Frequency measuring repetition in periods	periods	X	X	X	X	X	X	4	
f ₁ <(>)	f+1+<(>)	Pickup value for frequency element 1	Hz	X	X	X	X	X	X	4800	
t _{f1} >	f+1+<(>)+t>	Tripping delay for frequency element 1	S	X	X	X	X	X	X	0.1	
f ₂ <(>)	f+2+<(>)	Pickup value for frequency element 2	Hz	X	X	X	X	X	X	4900	
t _{f2} >	f+2+<(>)+t>	Tripping delay for frequency element 2	S	X	X	X	X	X	X	0.1	
f ₃ <(>)	f+3+<(>)	Pickup value for frequency element 3	Hz	X	X	X	X	X	X	5100	
t _{f3} >	f+3+<(>)+t>	Tripping delay for frequency element 3	S	X	X	X	X	X	x	0.1	
df	Δθ_df	Pickup value for rate of frequency df/dt in	Hz/s	X	X	X	X	X	X	EXIT	
dt	1/3_dt	Measuring repetition for df/dt	periods	X	X	X	X	X	X	4	
Δθ 1/3	Δθ_df	Vector surge tripping logic		X	X	X	X	X	X	1PH	
Δθ	1/3_dt	Pickup value for vector surge	°	X	X	X	X	X	X	2.0	
U _B >	f+Δθ_df	Voltage threshold for frequency, df/dt and vector surge measuring	%	X	X	X	X	X	X	20	

Protection parameters: Phase and earth fault protection

Symbol	LED	Function	Unit	Relay type						Default set-tings		Actual settings	
				MRG3	MRG3-I	MRG3-U0	MRG3-IE	MRG3-IU0	MRG3-IER	Set 1	Set 2	Set1	Set 2
I>	I+1+>	Pickup value for phase over current element	%		X		X	X	X	20			
I> Char	I+1	Tripping characteristic for phase over current element			X		X	X	X	DEFT			
tI>	I+1+>+t>	Tripping time (factor) for phase over current element	(s)		X		X	X	X	0.04			
I>_Reset	I+1+>+t>	Reset mode for phase over current element			X		X	X	X	0s			
I>>	I+2+>	Pickup value for fast phase – short-circuit tripping	%		X		X	X	X	50			
tI>>	I+2+>+t>	Tripping value of the fast phase short-circuit tripping	s		X		X	X	X	0.04			
U ₀ >	U ₀ +1	Warning/tripping of the U ₀ > element				X		X		warn			
U ₀ >+t>	U ₀ +1+>+t>	Tripping delay for the 1 st residual voltage element	s			X		X		0.1			
U ₀ >>	U ₀ +2+>	Pickup value for the 2 nd residual voltage element	%			X		X		10			
U ₀ >>+t>	U ₀ +2+>+t>	Tripping delay for the 2 nd residual voltage element	s			X		X		0.1			
I _E >	I _E +1	Warning/tripping of the I _E > element					X		X	warn			
I _E >	I _E +1+>	Pickup value for earth over current	%				X		X	1			
I _E > Char	I _E +1	Tripping characteristic for earth over current element					X			DEFT			
tI _E >	I _E +1+>+t>	Tripping time (factor) for the earth over current element	(s)				X			0.04			
tI _E >→	I _E +1+>+t>+→	Tripping time (factor) for earth over-current element in forward direction	(s)				X		X	0.1			
tI _E >←	I _E +1+>+t>+←	Tripping time for earth over current element backward direction	(s)						X	0.1			
I _E >_Reset	I+1+>+t>	Reset mode for earth over current element					X			0s			
I _E >>	I _E +2+>	Pickup value for fast earth short circuit tripping	%				X		X	1			
tI _E >>	I _E +2+>+t>+→	Tripping time for the earth short-circuit tripping	s				X			0.04			
tI _E >>→	I _E +2+>+t>+→	Tripping value of fast earth short circuit tripping/forward direction	s				X		X	0.1			
tI _E >>←	I _E +1+>+t>+←	Tripping value of fast earth short circuit tripping/backward direction	s						X	0.1			
SIN/COS	I _E +1+2+>	Evaluation for isolated/compensated grids							X	SIN			
CB+>	CB+>	Tripping time for CB failure protection	s		X		X	X	X	EXIT			

Parameter for the fault recorder

Symbol/ LED	Function	Unit	Relay type						Default settings	Actual settings
			MRG3	MRG3-I	MRG3-U0	MRG3-IE	MRG3-IU0	MRG3-IER		
FR	Number of recordings		X	X	X	X	X	X	4	
FR	Saving of the recording at the occurrence		X	X	X	X	X	X	TRIP	
FR	Time prior to trigger impulse	s	X	X	X	X	X	X	0.05	

Parameter for the serial interface

Symbol	Function	Unit	Relay type						Default settings	Actual settings
			MRG3-I	MRG3-I	MRG3-U0	MRG3-IE	MRG3-IU0	MRG3-IER		
RS	Slave address of the serial interface		X	X	X	X	X	X	RS1	
RS*	Baud-Rate	Baud	X	X	X	X	X	X	9600	
RS*	Parity-Check		X	X	X	X	X	X	even	

Blocking function

Symbol	LED	Relay type						Default settings				Actual settings				
		MRG3	MRG3-I	MRG3-U0	MRG3-IE	MRG3-IU0	MRG3-IER	Set 1		Set 2		Set 1		Set 2		
								Block ing	No block ing	Block ing	No block ing	Block ing	No block ing	Block ing	No block ing	
U<	U+1+<	X	X	X	X	X	X	X		X						
U<<	U+2+<	X	X	X	X	X	X	X		X						
U>	U+1+>	X	X	X	X	X	X		X		X					
U>>	U+2+>	X	X	X	X	X	X		X		X					
f1<(>)	f+1+<(>)	X	X	X	X	X	X	X		X						
f2<(>)	f+2+<(>)	X	X	X	X	X	X	X		X						
f3<(>)	f+3+<(>)	X	X	X	X	X	X		X		X					
$\Delta\theta$	$\Delta\theta_df$	X	X	X	X	X	X	X		X						
df/dt	$\Delta\theta_df$	X	X	X	X	X	X	X		X						
I>	I+1+>		X		X	X	X		X		X					
I>>	I+2+>		X		X	X	X	X		X						
U ₀ >	U ₀ >			X		X			X		X					
U ₀ >>	U ₀ >>			X		X			X		X					
I _E >	I _E +1+>				X		X		X		X					
I _E >>	I _E +2+>				X		X		X		X					
CB+t>	CB+t>		X		X	X	X		X		X					

Assignment of the output relays

Symbol	LED	Device type						Default settings				Actual settings			
		MRG3	MRG3-I	MRG3-U0	MRG3-IE	MRG3-IU0	MRG3-IER	Relay 1	Relay 2	Relay 3	Relay 4	Relay 1	Relay 2	Relay 3	Relay 4
U< Alarm	U+1+<	X	X	X	X	X	X								
U< Ausl.	U+1+<+t>	X	X	X	X	X	X	X							
U<< Alarm	U+2+<	X	X	X	X	X	X								
U<< Ausl.	U+2+<+t>	X	X	X	X	X	X	X							
U> Alarm	U+1+>	X	X	X	X	X	X								
U> Ausl.	U+1+>+t>	X	X	X	X	X	X	X							
U>> Alarm	U+2+>	X	X	X	X	X	X								
U>> Ausl.	U+2+>+t>	X	X	X	X	X	X	X							
f1 Alarm	f+1	X	X	X	X	X	X								
f1 Ausl.	f+1+t>	X	X	X	X	X	X	X							
f2 Alarm	f+2	X	X	X	X	X	X								
f2 Ausl.	f+2+t>	X	X	X	X	X	X	X							
f3 Alarm	f+3	X	X	X	X	X	X								
f3 Ausl.	f+3+t>	X	X	X	X	X	X	X							
$\Delta\Theta$ Ausl.	$\Delta\Theta/df$	X	X	X	X	X	X	X							
df/dt Ausl.	$\Delta\Theta/df$	X	X	X	X	X	X	X							
I> Alarm	I+1+>		X		X	X	X								
I> Ausl.	I+1+>+t>		X		X	X	X		X						
I>> Alarm	I+2+>		X		X	X	X								
I>> Ausl.	I+2+>+t>		X		X	X	X		X						
U ₀ > Alarm	U ₀ +1+>			X		X	X								
U ₀ > Ausl.	U ₀ +1+>+t>			X		X				X					
U ₀ >> Alarm	U ₀ +2+>			X		X									
U ₀ >> Ausl.	U ₀ +2+>+t>			X		X				X					
IE> Alarm	IE+1+>				X										
IE> Ausl.	IE+1+>+t>				X					X					
IE> Alarm→	IE+1+>+→						X								
IE> Ausl. →	IE+1+>+t>+→						X			X					
IE> Alarm←	IE+1+>+←						X								
IE> Ausl.←	IE+1+>+t>+←						X			X					
IE>> Alarm	IE+2+>				X										
IE>> Ausl.	IE+2+>+t>				X					X					
IE>> Alarm→	IE+2+>+→						X								
IE>> Ausl. →	IE+2+>+t>+→						X			X					
IE>> Alarm←	IE+2+>+←						X								
IE>> Ausl.←	IE+2+>+t>+←						X			X					
tCB Ausl.	CB+t>		X		X	X	X				X				

Setting of code jumpers

Front plate

Code jumper	J1		J2		J3	
	Default settings	Actual settings	Default settings	Actual settings	Default settings	Actual settings
Plugged						
Not plugged	X		No function		X	

Digital inputs

Code jumper	Low/High-range for the DI_1 input		Low/High-range for the DI_2 input	
	Default settings	Actual settings	Default settings	Actual settings
Low=plugged	X		X	
High=not plugged				

Measuring range residual voltage

Code jumper	Measuring voltage range phase U_L1		Measuring voltage range Phase U_L2		Measuring voltage range phase U_L3	
	Default settings	Actual settings	Default settings	Actual settings	Default settings	Actual settings
100V						
400V	X		X		X	

Range of measuring method for residual voltage

Code jumper	Range of measuring method for residual voltage U0	
	Default settings	Actual settings
3PHA		
1:1	X	

This technical manual is valid for

Software-Version: MRG3 D01-1.00 mit SEG ProOpenData-Protokoll

MRG3- I D02-1.00

MRG3-U0 D03-1.00

MRG3-IE D04-1.00

MRG3-IU0 D05-1.00

MRG3-IER D06-1.00

MRG3-M D51-1.00 mit Modbus Protokoll

MRG3-I-M D52-1.00

MRG3-U0-M D53-1.00

MRG3-IE-M D54-1.00

MRG3-IU0-M D55-1.00

MRG3-IER-M D56-1.00

Technical data subject to change without notice!

**SEG****Woodward SEG GmbH & Co. KG**

Krefelder Weg 47 · D – 47906 Kempen (Germany)
Postfach 10 07 55 (P.O.Box) · D – 47884 Kempen (Germany)
Phone: +49 (0) 21 52 145 1

Internet

Homepage <http://www.woodward-seg.com>
Documentation <http://doc.seg-pp.com>

Sales

Phone: +49 (0) 21 52 145 635 · Telefax: +49 (0) 21 52 145 354
e-mail: kemp.electronics@woodward.com

Service

Phone: +49 (0) 21 52 145 614 · Telefax: +49 (0) 21 52 145 455
e-mail: kemp.pd@woodward.com